

EXOTIC SMOOTH STRUCTURES ON NON-SIMPLY CONNECTED  
4-MANIFOLDS

MUSTAFA TOPKARA

MARCH 2010

EXOTIC SMOOTH STRUCTURES ON NON-SIMPLY CONNECTED  
4-MANIFOLDS

A THESIS SUBMITTED TO  
THE GRADUATE SCHOOL OF NATURAL AND APPLIED SCIENCES  
OF  
MIDDLE EAST TECHNICAL UNIVERSITY

BY

MUSTAFA TOPKARA

IN PARTIAL FULFILLMENT OF THE REQUIREMENTS  
FOR  
THE DEGREE OF DOCTOR OF PHILOSOPHY  
IN  
MATHEMATICS

MARCH 2010

Approval of the thesis:

**EXOTIC SMOOTH STRUCTURES ON NON-SIMPLY  
CONNECTED 4-MANIFOLDS**

submitted by **MUSTAFA TOPKARA** in partial fulfillment of the requirements  
for the degree of **Doctor of Philosophy in Mathematics Department, Middle East Technical University** by,

Prof. Dr. Canan Özgen

Dean, Graduate School of **Natural and Applied Sciences**

Prof. Dr. Zafer Nurlu

Head of Department, **Mathematics**

Prof. Dr. Yıldırım Ozan

Supervisor, **Mathematics Dept., METU**

**Examining Committee Members:**

Prof. Dr. Turgut Önder

Mathematics Dept., METU

Prof. Dr. Yıldırım Ozan

Mathematics Dept., METU

Assist. Prof. Dr. Ahmet Beyaz

Mathematics Dept., METU

Assist. Prof. Dr. Mohan Bhupal

Mathematics Dept., METU

Assist. Prof. Dr. Özgün Ünlü

Mathematics Dept., Bilkent Univ.

**Date:** 11.03.2010

I hereby declare that all information in this document has been obtained and presented in accordance with academic rules and ethical conduct. I also declare that, as required by these rules and conduct, I have fully cited and referenced all material and results that are not original to this work.

Name, Last name : Mustafa Topkara

Signature :

# ABSTRACT

## EXOTIC SMOOTH STRUCTURES ON NON-SIMPLY CONNECTED 4-MANIFOLDS

Topkara, Mustafa  
Ph. D., Department of Mathematics  
Supervisor: Prof. Dr. Yıldray Ozan

March 2010, 37 pages

In this thesis, we study exotic smooth structures on 4-manifolds with finite fundamental groups. For an arbitrary finite group  $G$ , we construct an infinite family of smooth 4-manifolds with fundamental group  $G$ , which are all homeomorphic but mutually non-diffeomorphic, using the small symplectic manifold with arbitrary fundamental group constructed by S. Baldrige and P. Kirk, together with the methods of A. Akhmedov, R.İ. Baykur and D. Park for constructing infinite families of exotic simply connected 4-manifolds. In the final chapter, pairs of small exotic 4-manifolds with a cyclic fundamental group of any odd order are constructed.

Keywords: Four dimensional manifolds, exotic differential structures, symplectic manifolds.

# ÖZ

## BAŞİT BAĞLANTILI OLMAYAN 4 BOYUTLU MANİFOLDLAR ÜZERİNDE EGZOTİK DÜZGÜN YAPILAR

Topkara, Mustafa  
Doktora, Matematik  
Tez Yöneticisi : Prof. Dr. Yıldray Ozan

Mart 2010, 37 sayfa

Bu tez, sonlu temel gruba sahip 4 boyutlu manifoldlar üzerindeki egzotik düzgün yapılar üzerinedir. Herhangi sonlu  $G$  grubu için, temel grubu  $G$  olan ve aralarında difeomorfik olmayan sonsuz bir homeomorfik 4 boyutlu manifold ailesini, S. Baldrige ve P. Kirk tarafından üretilmiş küçük simplektik manifoldları ve A. Akhmedov, R.I. Baykur ve D. Park tarafından küçük egzotik basit bağlantılı sonsuz 4 boyutlu manifold aileleri üretmek için kullanılan yöntemleri kullanarak ürettik. Son bölümde ise, tek mertebeli devirsel temel gruba sahip küçük egzotik 4-manifold çiftleri üretilmiştir.

Anahtar Sözcükler: Dört boyutlu manifoldlar, egzotik diferansiyel yapılar, simplektik manifoldlar.

## ACKNOWLEDGEMENTS

I would like to acknowledge my gratitude to my supervisor Prof. Dr. Yıldray Ozan for all the guidance, depth of insight and motivation he offered during the whole period my PhD studies. Without his kindness and generous help, the whole process of study would surely be much more painful and less fruitful.

I would like to take this chance to thank the present and past staff of Mathematics Department. I owe not only most of my mathematical knowledge to my professors and colleagues there, but also my perception of what being a mathematician is.

I am indebted to the Mathematics Department of Mimar Sinan Fine Arts University, especially Prof. Dr. Fatma Senyücel, for offering me very good working conditions during the last year of my studies, which proved to be very valuable for me. I also should thank my colleagues Assist. Prof. Ahmet Bakkaloğlu and Şafak Özden there especially for providing me all the help when I needed it.

I should express by gratitude to Prof. Muhammed Uludağ from Galatasaray University for providing financial support during my PhD studies through a TUBITAK project.

I would like to thank the members of the examining committee for their kindness and valuable remarks.

I owe very much to my family for their trust and support they provided, and not only during the PhD studies but throughout my studentship. Surely I cannot thank them enough.

The final thanks are due Burcu Özge Eser who would deserve it just for her incredible patience with me, not mentioning everything else. She made me keep on even at the worst moments.

# TABLE OF CONTENTS

ABSTRACT	.....	iv
ÖZ	.....	v
ACKNOWLEDGEMENTS	.....	vi
TABLE OF CONTENTS	.....	vii
<b>1</b>	<b>INTRODUCTION</b>	<b>1</b>
<b>2</b>	<b>PRELIMINARIES</b>	<b>3</b>
2.1	Symplectic Manifolds	3
2.1.1	Symplectic Structures on Vector Spaces	3
2.1.2	Symplectic Structures on Manifolds	4
2.1.3	Luttinger Surgery	5
2.2	Topological Classification of 4-Manifolds	6
2.3	Seiberg-Witten Invariant and Surgeries	8
2.3.1	Surgery on Tori in 4-Manifolds	9
<b>3</b>	<b>EXOTIC MANIFOLDS WITH ARBITRARY FUNDAMENTAL GROUP</b>	
	12	
3.1	Symplectic Manifold with Arbitrary Fundamental Group	13
3.1.1	Generator Block	14
3.1.2	Relater Block	17
3.1.3	The Manifold $Y$	22
3.2	The Manifold $S^1 \times M_K$	22
3.3	Construction of the Infinite Family of Non-Diffeomorphic Manifolds	24
<b>4</b>	<b>EXOTIC MANIFOLDS WITH CYCLIC FUNDAMENTAL GROUP OF</b>	
	<b>ODD ORDER</b>	<b>28</b>
4.1	Construction Scheme	28



4.2 Exotic Manifolds with Cyclic Fundamental Groups of Odd Order . . . . .	29
REFERENCES . . . . .	34
VITA . . . . .	36

# CHAPTER 1

## INTRODUCTION

Unlike lower dimensions, a topological manifold of dimension four may carry more than one smooth structure. Since the discovery of this fact, smooth structures on 4-manifolds are being studied extensively.

Let  $M$  be a smooth four manifold. Any smooth manifold  $N$  which is homeomorphic but not diffeomorphic to  $M$  is called to be an *exotic*  $M$ . For example it is known that there are uncountably many exotic  $\mathbb{R}^4$ 's.

Research on exotic differential structures are mainly concentrated on finding small (in the sense of Euler characteristic) exotic copies of closed manifolds, the ultimate targets being  $S^4$ ,  $\mathbb{C}\mathbb{P}^2$  and  $S^2 \times S^2$ . The question of existence of an exotic  $S^4$  is called the *4-dimensional Poincare conjecture*.

Until recently, construction of exotic 4-manifolds relied mainly on the technique called rational blow-down, while in the past few years a procedure developed and first used by A. Akhmedov which requires gluing-up smaller manifolds and manipulating them with surgeries is widely used. Again, Donaldson invariant mostly left its role in distinguishing different smooth structures to Seiberg-Witten invariants. To determine the underlying topological structure, the theorem of M. Freedman [9] is used.

Using these techniques, S. Baldridge and P. Kirk constructed families of non-diffeomorphic smooth manifolds with certain classes of fundamental groups and the same topological invariants [3].

J. Park has constructed infinite exotic families of minimal symplectic 4-manifolds with any finitely presented group in [15].

Our main concern will be exotic 4-manifolds with non-trivial fundamental groups. In this case, the topological classification of Freedman has its analogue only for manifolds with finite cyclic fundamental groups, due to Hambleton and Kreck. Still, there is a weaker version for arbitrary finite fundamental groups. Also it is proved by R. Fintushel and R.J. Stern that Seiberg-Witten invariant

is not enough to distinguish the smooth structures on homeomorphic smooth non-simply connected 4-manifolds, which is still not known to be valid or not for simply-connected manifolds [6].

Another subject related to non-simply connected case is exotic group actions on manifolds. M. Ue proved that for any finite group  $G$ , there exists a smooth 4-manifold  $M_G$  such that  $G$  has infinitely many actions on  $M_G$  such that the orbit spaces are homeomorphic but pairwise non-diffeomorphic [18]. Also R. Fintushel, R.J. Stern and N. Sunukjian constructed an exotic free involution on  $S^4$  [7].

The main objective of this thesis is to construct small exotic manifolds with nontrivial fundamental groups. The main tools such as symplectic geometry, topological invariants and Seiberg-Witten invariants are briefly covered in Chapter 1.

We construct infinite families of exotic manifolds with arbitrary finite fundamental group in Chapter 3. The method is to take the sum of the symplectic manifold of S. Baldridge and P. Kirk with arbitrary fundamental group in [4] with  $T^4$  and apply appropriate surgeries to manipulate the smooth structure.

In Chapter 4, we concentrate on manifolds with cyclic fundamental groups of odd order, and we construct small exotic pairs of symplectic manifolds with fundamental group isomorphic to  $\mathbb{Z}_n$  for any odd value of  $n$ . The constructions are variants of the symplectic manifolds of A. Akhmedov, R.Ī. Baykur and D. Park in [1].

# CHAPTER 2

## PRELIMINARIES

### 2.1 Symplectic Manifolds

Symplectic geometry is a field of study which has strong connections with many subjects in mathematics and physics, mainly Hamiltonian mechanics. A symplectic manifold is a differentiable manifold which carries a certain kind of 2-form. Our main concern will be their use in distinguishing different differential structures. Some of the main definitions and features of symplectic geometry is described below.

#### 2.1.1 Symplectic Structures on Vector Spaces

First we give the definition a symplectic form on a vector space:

**Definition 2.1.** *Let  $V$  be a vector space and let  $\Omega : V \times V \rightarrow \mathbb{R}$  be a skew-symmetric bilinear non-degenerate form on  $V$ . Then  $(V, \Omega)$  is called a symplectic vector space and  $\Omega$  is called a symplectic form on  $V$ .*

By a process similar to Gram-Schmidt, it can be deduced that the vector space  $V$  with a symplectic form  $\Omega$  has a basis  $\mathcal{B} = (e_1, \dots, e_n, f_1, \dots, f_n)$  such that  $\Omega(e_i, f_j) = \delta_{ij}$ . In particular, a vector space must be even dimensional to carry a symplectic form and two symplectic vector spaces  $(V_1, \Omega_1)$  and  $(V_2, \Omega_2)$  with the same dimension are isomorphic as symplectic vector spaces, i.e. there exists an vector space isomorphism  $T : V_1 \rightarrow V_2$  such that  $T^*\Omega_2 = \Omega_1$ .

There are mainly two important classes of subspaces of a symplectic vector space. For a symplectic vector space  $(V, \Omega)$ , a subspace  $W < V$  is called a *symplectic subspace* of  $V$  if the restriction  $\Omega|_W$  defines a symplectic form on  $W$ , i.e. if  $(W, \Omega|_W)$  is a symplectic vector space itself. The other extreme is also important: A maximal subspace on which the form  $\Omega$  vanishes is called a *Lagrangian subspace*. A Lagrangian subspace is of half dimension of the symplectic vector space.

## 2.1.2 Symplectic Structures on Manifolds

The definition of a symplectic structure on a differentiable manifold is as follows:

**Definition 2.2.** *A differential manifold  $M$  with a closed non-degenerate 2-form  $\omega$  on it is called a symplectic manifold. In this case, the form  $\omega$  is called a symplectic form on  $M$ .*

The form  $\omega$  restricts to a skew-symmetric bilinear non-degenerate form  $\omega|_P$  on the tangent vector space  $T_P M$  of  $M$  at the point  $P$ . Thus, the symplectic form on a manifold could be defined as a closed 2-form which restricts to a symplectic form (in the sense of Definition (2.1)) at each point  $P \in M$ .

In the category of symplectic manifolds, equivalence is expressed in the following terms:

**Definition 2.3.** *The symplectic manifolds  $(M, \omega_1)$  and  $(N, \omega_2)$  are called symplectomorphic if there is a diffeomorphism  $f : M \rightarrow N$  such that  $f^*(\omega_2) = \omega_1$ .*

Since  $(T_P M, \omega|_P)$  is a symplectic vector space, only manifolds of even dimension can admit symplectic structures. An example is  $\mathbb{R}^{2n}$  with a particularly important symplectic form on it: Let the 2-form  $\omega = \sum_{k=1}^n dx_k \wedge dy_k$  be defined on  $\mathbb{R}^{2n}$ . This is a symplectic form and is called the *standard symplectic form*. The reason for the name is the the following theorem:

**Theorem 2.4** (Darboux Theorem). *Let  $(M, \omega)$  be a symplectic manifold and  $P \in M$ . Then  $P$  has a neighborhood  $U$  such that  $(U, \omega|_U)$  is symplectomorphic to  $\mathbb{R}^{2n}$  with the standard symplectic structure.*

The theorem implies that there is no local information on symplectic manifolds: locally they all have the standard symplectic structure.

The cotangent bundle  $T^* M$  of a smooth manifold  $M$  carries a canonical structure defined as follows: Let  $x_1, \dots, x_n$  be local coordinates on  $M$  and define coordinates  $y_i = dx_i$  on fibers of the cotangent bundle. Then the form defined by  $\omega = \sum_{i=1}^n dx_i \wedge dy_i$  is a symplectic form on  $T^* M$ .

**Definition 2.5.** *Let  $(M, \omega)$  be a symplectic manifold and let  $N \subset M$  be a differentiable submanifold and  $\iota : N \rightarrow M$  be the inclusion map. If  $\iota^* \omega$ , the pullback of the symplectic form by  $\iota$ , defines a symplectic structure on  $N$  (i.e. if  $T_P N$  is a*

(symplectic subspace  $T_P M$ ) then  $N$  is said to be a symplectic submanifold of  $M$ . If  $N$  is a maximal submanifold of  $M$  on which  $\iota^* \omega$  vanishes then  $N$  is said to be a Lagrangian submanifold of  $M$ .

The condition for Lagrangian submanifolds is in fact equivalent to  $T_P N$  being a maximal subspace of  $T_P M$  on which  $\omega|_P$  vanishes, and thus a Lagrangian submanifold has dimension half of the ambient manifold.

### 2.1.3 Luttinger Surgery

Luttinger surgery ([2], [13]) is a technique used to alter the symplectic manifold and obtain another symplectic manifold.

Let  $(M, \omega)$  be a symplectic 4-manifold and let  $T$  be a Lagrangian torus embedded in  $M$ . It is known that there exists a neighborhood  $\nu T$  of  $T$  symplectomorphic to a neighborhood of the zero section of the cotangent bundle of  $T$  with the canonical symplectic structure. Under this identification, which is called the *Lagrangian framing*, each torus  $T \times \{x\}$  is seen to be Lagrangian. The closure of this neighborhood is diffeomorphic to  $T \times D^2$ , which implies that such a torus should have self intersection zero.

Let  $\gamma$  be a simple closed homologically nontrivial curve on  $T$  with a co-orientation, i.e. a choice of normal direction. Now identify  $T$  with  $\mathbb{R}^2/\mathbb{Z}^2$  such that  $\gamma$  is identified with the first coordinate axis  $x_1$  and the co-orientation agrees with the positive direction of the second coordinate  $x_2$  on  $\mathbb{R}^2$ . On the cotangent bundle  $T^* \mathbb{R}^2$ , define the coordinates on the fibers as  $y_i = dx_i$ . Thus the form  $\omega = dx_1 \wedge dy_1 + dx_2 \wedge dy_2$  is the canonical symplectic structure defined on the cotangent bundle of  $\mathbb{R}^2$  which determines the symplectic structure on  $T^* T$  after taking the quotient.

Choose a positive real number  $r$  such that the closed neighborhood  $U_r = \mathbb{R}^2/\mathbb{Z}^2 \times [-r, r] \times [-r, r]$  is identified with a subset of  $\nu T$  in  $M$ . Now we need a smooth function  $\chi : [-r, r] \rightarrow [0, 1]$  such that  $\chi(t) = 0$  for  $t < -\frac{r}{3}$  and  $\chi(t) = 1$  for  $t > \frac{r}{3}$ . For any  $k \in \mathbb{Z}$  define the self-diffeomorphism  $\phi_k : U_r \setminus U_{r/2} \rightarrow U_r \setminus U_{r/2}$  by

$$\phi_k(x_1, x_2, y_1, y_2) = (x_1 + k\chi(y_1), x_2, y_1, y_2)$$

if  $y_2 > 1/2$  and  $\phi_k \equiv \text{id}$  otherwise. This map also preserves the symplectic

structure, hence the manifold

$$M(T, \gamma, 1/k) = M \setminus U_{\frac{r}{2}} \cup_{\phi_k} U_r$$

is symplectic. This operation on manifold is called *Luttinger surgery* on the torus  $T$  along  $\gamma$  with surgery coefficient  $k$ . In Section 2.3.1 we will see this surgery as a special case of another more general type, namely  $p/q$  surgery, which in general does not preserve symplecticity and it will justify why we use  $1/k$  in the notation and not  $k$ .

## 2.2 Topological Classification of 4-Manifolds

The intersection form of a 4-manifold  $M$  is the symmetric bilinear form  $Q_M : H^2(M, \partial M; \mathbb{Z}) \times H^2(M, \partial M; \mathbb{Z}) \rightarrow \mathbb{Z}$  defined by the cup product. By Poincare duality  $H^2(M, \partial M; \mathbb{Z}) \cong H_2(M, \mathbb{Z})$ , this operation can be considered to be defined on  $H_2(M, \mathbb{Z})$ . Furthermore, if  $a \in H_2(M, \mathbb{Z})$  is a torsion element then  $Q_M(a, b) = 0$  for any  $b \in H_2(M, \mathbb{Z})$ . Hence we can quotient out the torsion part and consider  $Q_M$  to be defined on the free abelian group  $H_2(M, \mathbb{Z})/Tors$ .

The intersection form of a closed 4-manifold has determinant  $\pm 1$ . Such bilinear forms are called as *unimodular*. Obviously, the intersection form of a manifold is determined by and depends only on the homotopy type of the manifold.

### Simply-connected manifolds

The simply-connected topological manifolds are classified by the intersection form and one more invariant as described in the following theorem due to Freedman:

**Theorem 2.6.** *Given a unimodular bilinear form  $Q$ , there exists a simply connected topological manifold  $M$  such that the intersection form  $Q_M$  on  $M$  is isomorphic to  $Q$ . For an even form, there exists only one homeomorphism class with this property. If  $Q$  is even then there exists exactly two such topological types which can be distinguished by their Kirby-Siebenmann invariants.*

*Kirby-Siebenmann invariant* is a  $\mathbb{Z}_2$ -valued obstruction to triangulation and hence it vanishes on smooth manifolds. As a result, if  $Q$  is an even intersection

form then any smooth manifold with this intersection form has the same Kirby-Siebenmann invariant so they are homeomorphic. As a consequence, topological type of a simply-connected smooth 4-manifold is completely determined by the isomorphism class of its intersection form. Now we will introduce some basic invariants of bilinear forms that determine the isomorphism class.

Given a unimodular (so, non-degenerate) integral bilinear form  $Q$  on a free abelian group  $A$ , extend the operation  $Q$  to be defined on  $A \otimes_{\mathbb{Z}} \mathbb{R}$  and then diagonalize. Denote the number of  $+1$ 's on the diagonal by  $b_2^+$  and the number of  $-1$ 's by  $b_2^-$ . The *signature* of  $Q$  is defined to be  $\sigma(Q) = b_2^+ - b_2^-$ . If the diagonal consists only of  $+1$  (resp.  $-1$ ) values, i.e.  $b_2^- = 0$  (resp.  $b_2^+ = 0$ ) then  $Q$  is called a *positive definite* (resp. *negative definite*) bilinear form. If it is neither positive nor negative definite then it is called *indefinite*.

The *parity* of a bilinear form is defined as follows: If  $Q(a, b)$  is even for any  $a, b \in A$  then  $Q$  is called to be even, otherwise it is called *odd*.

Obviously rank, parity and signature of a bilinear form is invariant under isomorphism. The converse is also true for indefinite bilinear forms: if the rank, parity and signature of two bilinear forms are the same then they are isomorphic. So we obtain a complete classification of topological type of simply-connected closed differential 4-manifolds with indefinite intersection form in terms of these three invariants.

### Non-simply Connected Case

A similar classification is also proved for a certain class of non-simply connected 4-manifolds:

**Theorem 2.7** (Hambleton, Kreck, [11]). *Let  $M$  be a closed oriented topological 4-manifold with cyclic fundamental group of odd order. Then the homeomorphism class of  $M$  is determined by its intersection form and Kirby-Siebenmann invariant.*

Again we conclude that the topological type of smooth manifolds with cyclic fundamental group of odd order is determined by their intersection form since their Kirby-Seibenmann invariants vanish. The corresponding result for general types of finite fundamental groups is more subtle:



**Theorem 2.8** (Hambleton, Kreck, [11]). *There exists finitely many homeomorphism classes of topological 4-manifolds with a prescribed finite fundamental group and Euler characteristic up to homeomorphism.*

## 2.3 Seiberg-Witten Invariant and Surgeries

Seiberg-Witten invariant is a more refined version of its ancestor, Donaldson invariant. For a wide class of 4-manifolds it is a diffeomorphism type invariant.

Seiberg-Witten invariant of a 4-manifold  $M$  is defined as a certain function from the set of  $\text{Spin}^c$  structures on  $M$  to  $\mathbb{Z}$ . The set of  $\text{Spin}^c$  structures on  $M$  are in one-to-one correspondence with the *characteristic elements* in  $H_2(M; \mathbb{Z})$  if  $H_1(M; \mathbb{Z})$  has no 2-torsion (in particular, if  $M$  is simply-connected or has fundamental group of odd order). The characteristic elements are defined as the elements of  $H_2(M; \mathbb{Z})$  whose Poincare duals reduce to the second Stiefel-Whitney class of  $M$  modulo 2. Hence Seiberg-Witten invariant can be viewed as a function

$$\text{SW}_M : \{ \sigma \in H_2(M; \mathbb{Z}) : \text{PD}(\sigma) \equiv w_2 \pmod{2} \} \rightarrow \mathbb{Z} .$$

The definition of Seiberg-Witten invariant involves a metric defined on  $M$  but it is known that the invariant is independent of the choice of the metric and depends only on the smooth structure on  $M$  up to sign if  $b_2^+ > 1$ , or  $b_2^+ = 1$  and  $b_2^- \leq 9$ .

For  $\beta \in H_2(M, \mathbb{Z})$ , if  $\text{SW}_M(\beta) \neq 0$  then  $\beta$  (and its Poincare dual  $\text{PD}(\beta) \in H^2(M; \mathbb{Z})$ ) is called a *basic class* of  $M$ . The value of Seiberg-Witten invariant at  $\beta$  and  $-\beta$  are the same up to sign and its value at  $-\beta$  can be obtained as

$$\text{SW}_M(-\beta) = (-1)^{\frac{e(M)+\sigma(M)}{4}} \text{SW}_M(\beta)$$

hence if  $\beta$  is a basic class then so is  $-\beta$ . It is known that a manifold may have a finite number of basic classes.

The self-intersection of a basic class of a symplectic manifold is given by the following theorem:

**Theorem 2.9.** *Let  $M$  be a closed symplectic 4-manifold with  $b_2^+ > 1$  and let  $\beta$  be a basic class. Then*

$$\beta^2 = 2e(M) + 3\sigma(M) \tag{2.1}$$

where  $e(M)$  is the Euler characteristic of  $M$ .

If all basic classes of a 4-manifold satisfy the equation (2.1) then the manifold is called to be of *simple type*. In particular, symplectic manifolds with  $b_2^+ > 1$  are of simple type by the theorem above. If a manifold is of simple type then the inequality

$$[\Sigma]^2 + |\beta \cdot [\Sigma]| \leq 2g(\Sigma) - 2 \quad (2.2)$$

which is phrased as *adjunction inequality* holds, where  $\Sigma$  is an embedded surface of genus  $g(\Sigma) > 0$  in the manifold  $M$  and  $\beta$  is a basic class. By the following theorem, we see that symplectic manifolds have at least one such basic class hence Seiberg-Witten invariant is non-trivial on symplectic manifolds.

**Theorem 2.10** (Non-vanishing theorem, Taubes [16]). *Let  $M$  be a closed symplectic 4-manifold with  $b_2^+(M) > 1$  and let  $c_1(M)$  be its first Chern class. Then  $\text{SW}_M(c_1(M)) = \pm 1$ .*

The Seiberg-Witten invariant is trivial on certain type of manifolds, described in the following theorem:

**Theorem 2.11** (Vanishing theorem, Witten [20]). *Let  $M$  be a smooth closed oriented 4-manifold with  $b_2^+(M) > 1$ .*

- *If  $M$  admits a metric with positive scalar curvature then  $\text{SW}_M \equiv 0$*
- *If  $M = M_1 \# M_2$  with  $b_2^+(M_i) > 1$  for  $i = 1, 2$  then  $\text{SW}_M \equiv 0$*

### 2.3.1 Surgery on Tori in 4-Manifolds

Here we will describe a surgery operation on 4-manifolds which is more general than Luttinger surgery of Section 2.1.3.

Let  $T \subseteq M$  be an embedded torus in the smooth 4-manifold  $M$  such that  $T \cdot T = 0$  and  $0 \neq [T] \in H_2(M, \mathbb{Z})$ . Since  $T$  has self intersection zero, it has a closed neighborhood  $\nu T \cong T \times D^2$ . We fix the framing given by this identification. Let  $\gamma$  be a simple closed curve on  $T$  and let  $\gamma' \subseteq \partial(\nu T) \cong T^3$  be a loop which is parallel to  $\gamma$  in  $\nu T$  under the framing given by the identification, or equivalently  $\gamma' = \gamma \times \{y\}$  where  $y \in \partial D^2$ . Let  $\mu_T$  be a meridian circle to  $T$  in  $\partial(\nu T)$ , i.e. boundary of a disc  $\{x\} \times D^2$  in the given identification.

The surgery operation, named  $p/q$  surgery, involves removing the neighborhood of  $\nu T$  of  $T$  in  $M$  and gluing it back using the curve  $\gamma$  and a rational number  $p/q$  (possibly infinity, i.e.  $1/0$ , which gives the manifold  $M$  itself after the surgery) which describes framing of the surgery to obtain  $M_{T,\gamma}(p/q)$ , namely we consider a map

$$\phi : \partial(T^2 \times D^2) \rightarrow \partial(\nu T)$$

such that

$$\phi_*(\partial D^2) = p[\mu_T] + q[\gamma'] \in H_1(\partial(M \setminus \nu T); \mathbb{Z})$$

We denote the surgered manifold as

$$M_{T,\gamma}(p/q) = (M \setminus \nu T) \cup_{\phi} T^2 \times D^2 ,$$

where  $\phi$  describes the gluing on the boundaries.

By Seifert-Van Kampen theorem we get the fundamental group of the resulting manifold as

$$\pi_1(M_{T,\gamma}(p/q)) = \pi_1(M \setminus \nu T) / \langle [\mu_T]^p [\gamma']^q = 1 \rangle . \quad (2.3)$$

We observe that Luttinger surgery described in Section 2.1.3 is a particular case of  $p/q$  surgery, where  $M(T, \gamma, 1/n)$  defined there corresponds to  $M_{T,\gamma}(1/n)$  in terms of  $p/q$ -surgery.

Let  $\beta_0$  be a characteristic element of  $M_{T,\gamma}(0)$ . Then after  $1/n$ -surgery (as in Luttinger surgery) there exists certain characteristic elements  $\beta_n \in H_2(M_{T,\gamma}(1/n); \mathbb{Z})$  and  $\beta \in H_2(M, \mathbb{Z})$  whose Seiberg-Witten values can be obtained in terms of Seiberg-Witten values of  $\beta \in H_2(M, \mathbb{Z})$  and  $\beta_0 \in H_2(M_{T,\gamma}(0))$  via the formula [14]

$$SW_{M_{T,\gamma}(1/n)}(\beta_n) = SW_M(\beta) + n \sum_{i \in \mathbb{Z}} SW_{M_{T,\gamma}(0)}(\beta_0 + 2i[T]) . \quad (2.4)$$

Assume that  $M_{T,\gamma}(0)$  has only one basic class up to sign which is not a multiple of  $[T]$ . Then the sum in the formula (2.4) above has at most one non-zero term. If we also assume that  $M$  is symplectic, then  $1/n$ -surgeries can be realized as Luttinger surgeries. If the manifold  $M_{T,\gamma}(0)$  is also symplectic then we obtain that the classes  $\beta$  and  $\beta_0$  are the only basic classes of  $M$  and  $M_{T,\gamma}(0)$ , hence

they are the canonical classes thus the value of Seiberg-Witten invariant at the characteristic class  $\beta$  is  $\pm 1$ . Hence the manifolds  $M_{T,\gamma}(1/n)$  has only one basic class up to sign and the formula yields that the Seiberg-Witten invariants of the manifolds  $M_{T,\gamma}(1/n)$  are all different hence none of the manifolds  $M_{T,\gamma}(1/n)$  obtained by  $1/n$ -surgery are pairwise diffeomorphic.

We have a more general version of this fact for manifolds which do not need to have one basic class or to be symplectic:

**Theorem 2.12.** *[8] Let  $M$  be a closed oriented smooth 4-manifold. Let  $T \subset M$  be a torus and  $\gamma \subset T$  be a loop as described for  $p/q$ -surgery. Assume also that  $M_{T,\gamma}(0)$  has non-trivial Seiberg-Witten invariant and  $\gamma'$  is null-homologous in  $M \setminus \nu T$ . Then the family*

$$\{M_{T,\gamma}(1/n) : n \in \mathbb{N}\}$$

*has an infinite subset which are pairwise non-diffeomorphic. Furthermore, if the manifold  $M_{T,\gamma}(0)$  has a single basic class then all manifolds in the given family are pairwise non-diffeomorphic.*

This theorem reduces the problem of constructing exotic manifolds to finding an appropriate torus in the zero-surgered manifold.

# CHAPTER 3

## EXOTIC MANIFOLDS WITH ARBITRARY FUNDAMENTAL GROUP

In this chapter, for any finite group  $G$ , we will find an infinite family of homeomorphic 4-manifolds with fundamental group  $G$  which are pairwise non-diffeomorphic. The construction will be by gluing up two manifolds: First one is the symplectic manifold with arbitrary fundamental group constructed by S. Baldridge and P. Kirk ([4], Theorem 14) which will supply us with the desired fundamental group. The second part will be the manifold  $S^1 \times M_K$  described in the article [1] of A. Akhmedov, R.Ī. Baykur and D. Park, on which we will apply surgeries and manipulate the differential structure.

J. Park has proved the following theorem:

**Theorem 3.1.** [15] *Let  $\chi_h$  denote the holomorphic Euler characteristic and  $c_1^2$  denote the square of the first Chern class. For each finitely generated group  $G$ , there exists constants  $r_G$  and  $t_G$  such that for any  $x \geq t_G$  and  $0 \leq c \leq r_G x$ , there exists a minimal symplectic 4-manifold  $X$  with  $\chi_h(X) = x$  and  $c_1^2(X) = c$  which admits infinitely many different smooth structures.*

Let  $G$  be a group. Let  $X = \{x_i\}_{i \in \Lambda}$  be a set and let  $R = \{w_j\}_{j \in \Omega}$  be a set of words in letters from  $X$ . The pair  $X, R$  is called a *presentation* of  $G$  if  $G$  is isomorphic to  $F_X/N$  where  $F_X$  is the free group generated by the elements of  $X$  and  $N$  is the subgroup of  $F_X$  normally generated by the elements of  $R$ . We will denote such a presentation of a group  $G$  as  $\langle X|R \rangle$  where  $X$  is called the set of generators and  $R$  is called the set of relations. We will occasionally identify a presentation with the group and write  $G = \langle X|R \rangle$ . A presentation is said to be finite if both  $X$  and  $R$  is finite.

### 3.1 Symplectic Manifold with Arbitrary Fundamental Group

The following construction of the small symplectic manifold  $Y$  is due to S. Baldrige and P. Kirk ([4], [5]).

Let  $\Sigma$  be an orientable surface and let  $H : \Sigma \rightarrow \Sigma$  be a diffeomorphism on  $\Sigma$  with a fixed point  $x_0 \in \Sigma$ . Denote the mapping torus of  $H$  by  $M$ , which is defined as  $M = \Sigma \times [0, 1] / \sim$  where the relation  $\sim$  is given by  $(x, 0) \sim (f(x), 1), x \in \Sigma$ . Note that  $M$  is a fiber bundle on  $S^1$  with fiber  $\Sigma$  and projection map  $\pi_M : M \rightarrow S^1$  is defined as  $\pi_M(x, t) = t$ . The fixed point  $x_0$  of  $H$  gives rise to a section  $S = S_1 \rightarrow M$ , of the bundle given by  $t \mapsto (x_0, t)$ . The fundamental group of  $M$  is determined by  $\pi_1(M)$  and  $H$  via the following result:

**Proposition 3.2.** *Let  $H : \Sigma \rightarrow \Sigma$  be a diffeomorphism of the surface  $\Sigma$  with a fixed point. Let  $\pi_1(M)$  has a representation  $\langle X | R \rangle$ . Then*

$$\pi_1(M) = \langle X \cup \{t\} | R \cup \{H_*(x) = txt^{-1} : x \in \pi_1(\Sigma)\} \rangle .$$

Consider the 4-manifold  $N = M \times S^1$ . This manifold is a fiber bundle on  $T^2$  with fibers  $\Sigma$  where the projection map  $\pi_N$  is defined as  $\pi_N(m, s) = (\pi_M(m), s)$  for  $m \in M$  and  $s \in S^1$ . Let  $q_1, q_2 : M \rightarrow S^1$  be the composition of this map with projections to the first and second coordinates of  $T^2 = S^1 \times S^1$  respectively. This fibration has a section  $T^2 \rightarrow N$  defined as  $(t, s) \rightarrow (S(t), s)$ .

Now, we will describe a symplectic structure on  $N$  (cf.[17]). First, let's choose an arbitrary volume form  $g_0$  on the surface  $\Sigma$  and let  $g_1$  be the pull-back of  $g_0$  by  $H$ , i.e.  $g_1 = H^*(g_0)$ . Note that  $H : (\Sigma, g_0) \rightarrow (\Sigma, g_1)$  is an isometry by definition. For  $t \in [0, 1]$ , define  $g_t = tg_0 + (1 - t)g_1$ , which gives us the linear path from  $g_0$  to  $g_1$ . These volume forms define a 2-form  $\beta$  on  $M$  which satisfies  $\beta|_{\Sigma} = g_t$  where  $\Sigma$  is a fiber of  $N \rightarrow T^2$  and  $t$  is  $q_1(\Sigma)$ . A symplectic form on  $N$  can now be defined to be

$$\omega = p^*(\beta) + q_1^*(dt) \wedge q_2^*(ds) \tag{3.1}$$

where  $p : S^1 \times M \rightarrow M$  is the projection. For the construction of  $Y$  with arbitrary fundamental group, two building blocks will be used: We will have a manifold  $N$  which carries the generators, and we will glue manifolds of type  $P$  to obtain the

relations of the group.

### 3.1.1 Generator Block

Let  $G$  be a group with a finite presentation  $\langle X \mid R \rangle$  so that  $X = \{x_1, \dots, x_g\}$  and  $R = \{w_1, \dots, w_r\}$ . Instead of this presentation with  $g$  generators and  $r$  relations, we pass to a presentation with  $2g$  generators  $x_1, y_1, \dots, x_g, y_g$  and  $g + r$  relations  $x_1 y_1, \dots, x_g y_g, w'_1, \dots, w'_r$  where negative powers  $x_j^{-n}, n > 0$  of the generators in  $w_i$  are replaced with  $y_j^n$ . As a result, we obtain a presentation of  $G$  for which the relations contain no negative power of the generators in expense of increasing the number of the generators and relations.

In the following part, construction of some orientable surface  $\Sigma = \Sigma_{ng}$  will be described, in which each of the generators  $x_i, y_i$  are represented by several curves, which has a 1-form compatible with these curves and in which the relations  $w_j$  correspond to some disjoint curves  $\gamma_j$ .

Consider the torus  $T^2 = S^1 \times S^1$  where  $S^1$  is viewed as the unit circle in the complex plane and let  $X = S_1 \times \{1\}$  and  $Y = \{1\} \times S^1$ , with the same orientation as the parametrization of the components. Let  $D^2$  be a small disc away from  $X \cup Y$ . A 1-form on  $T$  which vanishes on  $D^2$  and restricts to a volume form on  $X$  and  $Y$  can be described as follows: Let  $\phi : T^2 \rightarrow T^2$  be a map that is constant on  $D^2$  and is a diffeomorphism on  $T \setminus D^2$ . Also, let  $f : T^2 \rightarrow S^1$  be defined as  $f(e^{ia}, e^{ib}) = e^{i(a+b)}$ . Now, pull back the volume form  $dt$  on  $S^1$  described by the usual parametrization  $t \rightarrow e^{it}$  onto  $T$  via  $f$  and  $\phi$  to obtain the 1-form  $\theta = \phi^*(f^*(dt))$ . Note that  $\theta$  is strictly positive on a tangent vector of  $X$  and  $Y$  with positive direction with respect to the orientations of these curves.

By *length*  $n_j$  of a relation  $w'_j$ , we mean the length of the word avoiding the powers, i.e. if  $w_j = z_1^{k_1} \dots z_m^{k_m}$  with  $z_i \in \{x_1, y_1, \dots, x_g, y_g\}$  and  $z_i \neq z_{i+1}$  then  $n_j = m$ . For example, the length of a word  $x_1^6 x_3 y_2^4 x_1^2$  would be 4. Denote length of an arbitrary word  $w$  by  $L_s(w)$ . Define

$$n = 1 + \sum_{j=1}^g n_j$$

The surface  $\Sigma$  with genus  $ng$  is described as follows: Consider the unit 2-

sphere  $S^2 \subset \mathbb{R}^3$  and let  $R$  be rotation by an angle  $2\pi/ng$  in the positive direction on  $xy$ -plane, fixing the north and south poles  $(0, 0, \pm 1)$ . Let  $D'$  be a disc around a point of  $S^2$  on the  $xy$ -plane small enough to guarantee that  $D' \cap R(D') = \emptyset$ . Define the complement of the interior of the orbit of  $D'$  under  $R$  as  $A = S^2 \setminus \bigcup_{i=0}^{ng-1} \text{int}(R^i(D'))$  which is  $S^2$  punctured  $ng$  times. Now, glue  $ng$  disjoint copies  $B_i$  of punctured torus  $T^2 \setminus D$  obtained previously along the boundaries of  $A$  to obtain  $F = A \natural_{i=0}^{ng-1} B_i$ .  $R$  extends naturally to  $F$  so that the restrictions  $R|_{B_i} : B_i \rightarrow B_{i+1}$  commute with the inclusions  $B_i \hookrightarrow F$ . Let  $B = \bigcup_{i=1}^{ng} B_i$  and observe that  $F = A \cup B$ .

We will name the images of the curves  $X$  and  $Y$  under the embeddings  $B_i \hookrightarrow F$  as  $X_i$  and  $Y_i$  respectively. Note that  $RX_i = X_{i+1}$  and  $RY_i = Y_{i+1}$ . Now, rename those generators as

$$\begin{aligned} X_{i,j} &= X_{i+jg} ; i < g, j < n \\ Y_{i,j} &= Y_{i+jg} ; i < g, j < n. \end{aligned}$$

If we let  $H = R^g$  then we observe that  $HX_{i,j} = X_{i,j+1}$ . Connecting these curves to the north pole  $p_0$  of  $S^2$  to obtain  $x_{i,j}$  and  $y_{i,j}$  respectively, we get a basis for  $\pi_1(F, p_0)$ .  $H$  acts on  $\pi_1(F, p_0)$  by  $H_*(x_{i,j}) = (x_{i,j+1})$ ,  $H_*(y_{i,j}) = (y_{i,j+1})$ .

We now represent each relation  $w'_i$  with  $\tilde{w}_i$  in letters  $x_{i,j}, y_{i,j}$ . First, concatenate the words  $w'_i$  to obtain  $w = w'_1 \cdot w'_2 \cdot \dots \cdot w'_r$ . If

$$w = z_{i_1}^{k_1} z_{i_2}^{k_2} z_{i_3}^{k_3} \dots z_{i_m}^{k_m} = \prod_{j=1}^m z_{i_j}^{k_j}$$

where  $z_i \in \{x_i, y_i\}$  then define

$$\tilde{w} = z_{i_1,1}^{k_1} z_{i_2,2}^{k_2} z_{i_3,3}^{k_3} \dots z_{i_m,m}^{k_m} = \prod_{j=1}^m (z_{i_j,j})^{k_j}$$

and obtain each  $\tilde{w}_i$  by the properties  $\tilde{w} = \tilde{w}_1 \cdot \tilde{w}_2 \cdot \dots \cdot \tilde{w}_m$  and  $L_s(\tilde{w}_i) = L_s(w'_i)$ . In words, we list the relations  $w_i$  in order and replace the index  $i_j$  of the  $j$ 'th letter we encounter by double index  $i_j, j$ . For example, if we have relations

$$(w'_1, w'_2, w'_3) = (x_1^6 x_3 y_2^4 x_1^2, x_2^2 y_5, y_1^4 y_3^3 y_1)$$



then the words  $\tilde{w}_i$  would be described as

$$(\tilde{w}_1, \tilde{w}_2, \tilde{w}_3) = (x_{1,1}^6 x_{3,2} y_{2,3}^4 x_{1,4}^2, x_{2,5}^2 y_{5,6}, y_{1,7}^4 y_{3,8}^3 y_{1,9})$$

Observe that each letter of the words  $\tilde{w}_i$  correspond to curves whose intersection with  $B$  lie completely on different punctured tori  $B_j$  and they can be joint to the base point  $p_0$  along meridians an  $A$ , which are disjoint. Thus, we can obtain curves  $\gamma_i$  which represent  $\tilde{w}_i$  in  $\pi_1(F, p_0)$  whose possible double points are in  $B$  and transverse, and which intersect one circle in  $A \cap B$  transversally and also such that  $\theta(\frac{d\gamma}{dt})$  is strictly positive on  $B$ . The last condition can be satisfied because the words  $\tilde{w}_i$  contain letters with only positive powers.

For the relations  $x_i y_i, 1 \leq i \leq n$  in the presentation, we consider the curves  $\gamma_{r+i}$  corresponding to he words  $x_{i,n} y_{i,n}$ . Note that we had not used these indices for the previous  $\gamma$  curves.

Define  $\theta$  to be the identically zero 1-form on  $A$ . Choose a function  $f_i$  on  $\gamma_i^{-1}(A)$  which vanish on  $\gamma_i^{-1}(A \cap B)$ , which is positive otherwise and such that  $\gamma_i^*(\theta) + df$  is a volume form on  $S^1$  and  $f(\gamma_i^{-1}(p_0)) = 0$ . The only intersection of the curves  $\gamma_i$  on  $A$  is at the base point  $p_0$ , so we can define the function  $f(p) = f_i(p)$  whenever  $p$  is in the intersection of the image of some  $\gamma_i$  and  $A$ . Since  $(\cup_i \text{Im}(\gamma_i))$  is compact, this function can be extended to a function  $f$  on  $F$  which vanish outside a neighborhood of images of the curves  $\gamma_i$  and on  $B$ .

Consider the mapping torus  $M = F \times_H S^1 = F \times [0, 1] / \langle (p, 0) \sim (H(p), 1) \rangle$  of  $H$ . Since  $\theta$  is invariant under  $H$ , the pull-back  $\text{pr}_1^*(\theta)$  of  $\theta$  under the projection  $\text{pr}_1 : F \times [0, 1] \rightarrow F$  determines a 1-form  $\Theta$  on  $M$  and since the north pole  $p_0$  is fixed under  $H$ , the fibration  $\text{pr}_2 : M \rightarrow S^1$  has a section. Extend the function  $f$  on the fiber  $F \times \{0\}$  smoothly to  $M$  and retain the name  $f$ . Now, define the 4-manifold  $N$  as  $N = M \times S^1$ . For small  $\epsilon$  values, the form

$$\omega_\epsilon = p^*(\beta) + q_1^*(dt) \wedge q_2^*(ds) + \epsilon p^*(\Theta + df) \wedge q_2^*(ds)$$

is a symplectic form on  $N$ , where the terms  $\beta, p, q_1, q_2, dt$  and  $ds$  are as described in Equation (3.1).

Define the symplectic tori  $T_0, \dots, T_{g+r}$  as follows: The north pole  $p_0$  in  $F$  is fixed under  $H$ , so we have a section  $\gamma_0$  in the mapping cone of  $H$ , corresponding

to  $t$ . Let  $T_i = \gamma_i \times S^1$  for  $i = 0, \dots, g+r$ . Observe that the fundamental group of  $N$  is

$$\pi_1(N) = \langle x_{i,j}, y_{i,j}, t \mid \prod_{i,j} [x_{i,j}, y_{i,j}] = 1, tx_{i,j}t^{-1} = x_{i,j+1}, ty_{i,j}t^{-1} = y_{i,j+1} \rangle \oplus \mathbb{Z}_s ,$$

thus if we quotient out  $\pi_1(N)$  by the normal subgroup generated by the the generators  $t$  and  $s$  (which are the generators of  $\pi_1(T_0)$ ), and the relations  $\tilde{w}_i$  and  $x_{i,j}y_{i,j}$  (which correspond to factors  $\gamma_i$  of  $T_i$  then we obtain the group  $G$ . Note that the Euler characteristic and the signature of  $N$  is zero.

### 3.1.2 Relater Block

To construct the relater building block  $P$  of the symplectic manifold  $Y$  with arbitrary fundamental group, we will describe a manifold  $B$  and regulate its fundamental group by taking symplectic fiber sum with a manifold  $W$  along a genus two surface to obtain a manifold  $R$ , then we will apply Luttinger surgery to kill a generator of the fundamental group. We first give the description of the regulating manifold  $W$  below.

#### The Manifold $W$

Consider  $T^2 \times S^2$  with product symplectic structure and resolve the three singular points of the surface  $(T^2 \times \{s_1\}) \cup (T^2 \times \{s_2\}) \cup (\{r\} \times S^2)$  to obtain a genus two symplectic surface  $F$ . This surface has self intersection four, thus the we can blow up the manifold four times and obtain

$$W = (T^2 \times S^2) \# \overline{\mathbb{C}\mathbb{P}^2}$$

in which the embedding of  $F$  has self intersection zero.

Observe that  $\pi_1(W) = \langle a_1, b_1, a_2, b_2 \mid [a_1, b_1], [a_2, b_2] \rangle$  and under the map  $\iota_* : \pi_1(F) \rightarrow \pi_1(W)$  induced by inclusion  $\iota : F \rightarrow W$ , we have

$$\iota_*(a_1) = a , \iota_*(b_1) = b , \iota_*(a_2) = a^{-1} , \iota_*(b_2) = b^{-1}$$

where  $a$  and  $b$  correspond to the generators of the fundamental group of  $T^2$  in the product  $T^2 \times S^2$ .

Let  $Q$  be a 4-manifold including a genus two surface  $G$  with self intersection zero. Let  $\phi : F \rightarrow G$  be a diffeomorphism such that  $\phi_*(g_i) = a_i$  and  $\phi_*(h_i) = b_i$ . Fix trivializations of the normal bundles of  $G$  and  $F$ , and choose a map  $\tau : F \rightarrow S^1$ . Take the fiber sum of  $Q$  and  $W$  with respect to the trivializations, twisting by  $\tau$ , i.e. define  $\tilde{\phi} : \partial(\nu F) \cong F \times S^1 \rightarrow \partial(\nu G) \cong G \times S^1$  by  $\tilde{\phi}(a, s) = (\phi(a), \tau(a)s)$  and glue  $Q \setminus \nu G$  with  $W \setminus \nu F$  along their boundary by  $\tilde{\phi}$  to obtain  $Q \#_{F,G} W$ .

**Proposition 3.3.**  $\pi_1(Q \#_{F,G} W) = \pi_1(Q) / \langle g_2 g_1, h_2 h_1, [g_1, h_1] \rangle$ .

*Proof.* Any element of  $\pi_1(Q)$  can be pushed away from  $G$ , therefore  $\iota_* : \pi_1(Q \setminus \nu G) \rightarrow \pi_1(Q)$  is a surjection, and its kernel is generated by the meridian  $\mu_G$  of  $G$  in  $Q$  because any element of the kernel bounds a 2-disk in  $Q$  which can be chosen to intersect  $G$  transversely at a finite number of points. By similar arguments and observing that the meridian  $\mu_F$  of  $F$  in  $W \setminus \nu$  is null-homotopic (because of the exceptional spheres), we get  $\pi_1(W \setminus \nu F) \cong \pi_1(W) = \mathbb{Z}_a \oplus \mathbb{Z}_b$

Seifert-Van Kampen theorem yields

$$\begin{aligned} \pi_1(Q \#_{F,G} W) &= \pi_1(Q \setminus \nu G) * \pi_1(W \setminus \nu F) / \langle \tilde{\phi}(\mu_F) \mu_G^{-1}, g_1 a^{-1}, h_1 b^{-1}, g_2 a, h_2 b \rangle \\ &= \pi_1(Q \setminus \nu G) * (\mathbb{Z}_a \oplus \mathbb{Z}_b) / \langle \mu_G, g_1 a^{-1}, h_1 b^{-1}, g_2 a, h_2 b \rangle \\ &= \pi_1(Q) * (\mathbb{Z}_a \oplus \mathbb{Z}_b) / \langle g_1 a^{-1}, h_1 b^{-1}, g_2 a, h_2 b \rangle \end{aligned}$$

Hence we can eliminate the generators  $a$  and  $b$  to obtain the desired result.  $\square$

### The Manifold $B$

Let  $H = S^1 \times S^1 \setminus D^2$  be a punctured symplectic torus with a base point  $h$  on the boundary and let  $X$  and  $Y$  be the curves corresponding to the factors, defined as for the punctured torus of the previous section. Join them to a base point  $h$  on the boundary to obtain the generators  $x, y \in \pi_1(H, h)$ . Let  $K$  and  $L$  be loops parallel to  $X$  and  $Y$ , respectively. Let  $D$  denote the Dehn twist along a curve parallel to  $X$ . Define the 3-manifold  $Z$  to be mapping torus of  $H$  and let  $C = Z \times S^1 = H \times_D S^1 \times S^1 = \{(a, u, v) : a \in Z; u, v \in [0, 1]\} / \langle (a, 0, v) \sim (D(a), 1, v), (a, u, 0) \sim (a, u, 1) \rangle$ . In  $C$ , rename  $h = (h, 0, 0)$ ,  $x = x \times (0, 0)$ ,  $y = y \times (0, 0)$  and let  $t = \{h\} \times [0, 1] \times \{0\}$ ,  $s = \{h\} \times \{0\} \times [0, 1]$ . In the following, we will use this coordinate system for notation and avoid the quotient relation.

Proposition 3.2 yields:

$$\begin{aligned}\pi_1(C, h) &= \langle x, y, t \mid txt^{-1} = x, tyt^{-1} = yx \rangle \oplus \mathbb{Z}_s \\ &= \langle x, y, t \mid [t, x], [y^{-1}, t]x^{-1} \rangle \oplus \mathbb{Z}_s\end{aligned}$$

Define the tori  $T_1 = K \times \{0\} \times [0, 1]$  and  $T_2 = L \times \{0\} \times [0, 1]$ . To calculate  $\pi_1(C \setminus T_1)$ , we first observe that

$$C \setminus T_1 = \{(a, u, v) : (a, u) \notin K \times \{0\}\} = (Z \setminus K) \times S^1,$$

and  $Z - K \equiv H \times [0, 1] / \langle (p, 0) \sim (H(p), 1) : p \in H \setminus K \rangle$ , thus by proposition 3.2 we get

$$\pi_1(C \setminus T_1) = \langle x, y, t \mid [y^{-1}, t]x^{-1}, [t, [x, y]] \rangle \oplus \mathbb{Z}_s$$

and the meridian  $\mu_1$  to  $T_1$  is represented by  $[t, x]$

Similarly,  $C \setminus T_2 = Z \times [0, 1] / \langle (z, 0) \sim (z, 1) : z \in Z \setminus T^2 \rangle$  and thus

$$\pi_1(C \setminus T_2) = \langle x, y, t, s \mid [t, x], [y^{-1}, t]x^{-1}, [s, x], [s, t] \rangle$$

and the meridian  $\mu_2$  to  $T_2$  is represented by  $[s, y]$ .

Now, consider a genus two symplectic surface  $\Sigma_2$  as the boundary sum of two punctured tori  $H_1, H_2$  by the inclusions  $\iota_i : H_i \hookrightarrow \Sigma_2, i = 1, 2$ . Identify each punctured torus with  $H$  above, fix a base point  $h$  on the common boundary and specify the curves  $x_1, y_1, x_2, y_2$  by the identifications  $\iota_i(x) = x_i$  and  $\iota_i(y) = y_i, i = 1, 2$ . Determine curves  $X_i, Y_i$  similarly.

Let  $D_1$  be a Dehn twist on a curve parallel to  $x_1$  and  $D_2$  be a Dehn twist on a curve parallel to  $y_2$ . Note that this will reverse the roles of  $x$  and  $y$  in the computations for  $H_2$ . Define diffeomorphism  $\phi : \Sigma_2 \rightarrow \Sigma_2$  as  $\phi = D_1 \circ D_2$ . Let  $Z$  be the mapping cone of  $\phi$ . Thus we have a fibration  $\pi_Z : Z \rightarrow S^1$

The boundary of  $H$  is represented by  $[x, y]$  in  $\pi_1(H)$ , thus  $\partial C \equiv T^3$  and  $\pi_1(\partial C) = \mathbb{Z}_{[x, y]} \oplus \mathbb{Z}_t \oplus \mathbb{Z}_s$ . Hence, by the computations for the mapping cone of  $H$  and Seifert-Van Kampen Theorem we get

$$\pi_1(Z) = \langle x_1, y_1, x_2, y_2, t \mid [x_1, y_1][x_2, y_2], [t, x_1], [y_1^{-1}, t]x_1^{-1}, [x_2^{-1}, t]y_2^{-1}, [t, y_2] \rangle \quad (3.2)$$

The manifold  $B = S^1 \times Z$  contains the tori  $T_1 = K \times \{0\} \times [0, 1]$  and  $T_2 = L \times [0, 1] \times \{0\}$ , where  $K$  is now chosen as a parallel copy of  $y_1$  in the first component of the boundary sum and  $L$  is a parallel copy of  $y_2$  in the second component. Also, we choose a fiber of the projection  $\iota \times \pi : Z = S^1 \times B \rightarrow S^1 \times S^1 = T^2$  disjoint from  $T_1$  and  $T_2$ , namely the genus two surface  $G = G \times \{1/2\} \times \{1/3\}$ . By Seifert-Van Kampen Theorem we compute the fundamental group of the complement of the tori as

$$\begin{aligned} \pi_1(B \setminus T_1 \cup T_2) = \langle x_1, y_1, x_2, y_2, s, t \mid [x_1, y_1][x_2, y_2], [y_1^{-1}, t]x^{-1}, [t, [x_1, y_1]], \\ [x_2^{-1}, t]y_2^{-1}, [t, y_2], [s, x_1], [s, y_1], [s, t], [s, y_2] \rangle . \end{aligned} \quad (3.3)$$

The meridians of  $T_1$  and  $T_2$  are represented as  $\mu_1 = [x_1, t]$  for  $T_1$  and  $\mu_2 = [x_2, s]$  for  $T_2$ .

By the method of Thurston [17], a symplectic structure can be defined on  $B$  with respect to which the tori  $T_1$  and  $T_2$  are Lagrangian and the surface  $G$  is symplectic in  $B$ . First, one takes an Riemannian metric  $g$  on  $G$  such that the area form  $\alpha(g)$  is preserved by the Dehn twists  $D_1$  and  $D_2$  with support away from  $L$ . The symplectic form is defined as

$$\omega p * (\alpha(g)) = p^*(\alpha(g)) + q_1^*(dt) \wedge q_2^*(ds),$$

where the terms are as described in Equation 3.1.

### Description of $P$

Define  $R$  as the symplectic fiber sum  $R = B \#_{F,G} W$  of  $B$  with the manifold  $W$ . Then the fundamental group of  $R$  can be computed by Proposition 3.3. Using proposition, we substitute  $x_2 = x_1^{-1}$  and  $y_2 = x_2^{-1}$ , and let  $x_1$  and  $y_1$  commute in equation 3.2 to obtain

$$\begin{aligned} \pi_1(R) &= \langle x_1, y_1, t \mid [x_1, y_1], [x_1, y_1][x_1^{-1}, y_1^{-1}], [t, x_1], \\ &\quad [y_1^{-1}, t]x_1^{-1}, [x_1, t]y_1, [t, y_1^{-1}] \rangle \oplus \mathbb{Z}_s \\ &= \mathbb{Z}_t \oplus \mathbb{Z}_s . \end{aligned}$$

By taking the fiber sum of  $B \setminus (T_1 \cup T_2)$  with  $W$ , we obtain  $R \setminus (T_1 \cup T_2)$ . By a similar computation based on Equation 3.3 on the fundamental group presentation of  $B \setminus (T_1 \cup T_2)$ , we get  $\pi_1(R \setminus (T_1 \cup T_2)) = \mathbb{Z}_t \oplus \mathbb{Z}_s = \pi_1(R)$ . In particular, we see that the meridian  $\mu_i$  to the tori  $T_i$  are trivial in  $\pi_1(R \setminus (T_1 \cup T_2))$ .

The tori  $T_i$  are homologically essential in  $H_2(R, \mathbb{Z})$ . To see this, consider a null-homotopy of  $\mu_i$  in  $R \setminus (T_1 \cup T_2)$  and take its union with a normal disk to  $T_i$  in  $\nu T_i$  bounded by the meridian  $\mu_i$ . This closed surface intersects  $T_i$  transversally once, so  $T_i$  cannot be homologically trivial.

The Euler characteristic of  $R$  is

$$\chi(R) = \chi(B \setminus \nu G) + \chi(W \setminus \nu F) - \chi(\partial(\nu F)) = (4 - (-2)) + (0 - (-2)) - 0 = 8 .$$

By Novikov additivity, we get the signature as  $\sigma(R) = \sigma(B) + \sigma(W) = -4$ .

Now, apply 1-Luttinger surgery to the manifold  $R$  on the torus  $T_1$  along  $S$  to obtain the manifold  $P = R(T_1, s, 1)$ . Then the fundamental group of  $P$  can be computed by equation 2.3 as

$$\pi_1(P) = \pi_1(R \setminus T_1) / \langle s\mu_1 \rangle = \pi_1(R) / \langle s \rangle = \mathbb{Z}_t$$

since  $\mu_1$  is trivial in  $\pi_1(R \setminus T_1)$ . Similarly, we obtain

$$\pi_1(P \setminus T_2) = \pi_1(R \setminus (T_1 \cup T_2)) / \langle s\mu_2 \rangle = \mathbb{Z}_t$$

. The Euler characteristic and the signature of  $R$  does not change with Luttinger surgery, so  $\chi(P) = 8$  and  $\sigma(P) = -4$ .

The sphere  $S \subset P$  obtained by taking the union of the disc bounded by  $\mu_2$  as a meridian in  $T_2$  and the disc obtained by the null-homotopy of  $\mu_2$  in  $P \setminus T_2$  intersects  $T_2$  transversally once, yielding that  $T_2$  is homologically non-trivial. So we can perturb the symplectic form on  $P$  so that  $T_2$  becomes a symplectic submanifold.

For a symplectic manifold  $N$  and a symplectic torus  $T \subset N$  with meridian  $\mu$ , the fundamental group of symplectic fiber sum of  $N$  and  $P$  on the tori  $T \subset P$

and  $T_2 \subset P$  can be computed by Seiberg-Van Kampen theorem as

$$\begin{aligned}\pi_1(N\#_{T,T_2}P) &= (\pi_1(N \setminus \nu T) * \pi_1(P \setminus \nu T_2)) / \langle x = t, y = s, \mu = \mu_2 \rangle \\ &= \pi_1(N) * \mathbb{Z}_t / \langle x = t \rangle = \pi_1(N) / \langle x \rangle\end{aligned}\tag{3.4}$$

using the triviality of  $\mu_2$  and  $s$  in  $\pi_1(P \setminus T_2)$ , where  $x$  and  $y$  are the generators of  $\pi_1(T)$  identified with  $t$  and  $s$  respectively under the symplectomorphism  $T \rightarrow T_2$ .

### 3.1.3 The Manifold $Y$

**Theorem 3.4** ([4], Theorem 14). *Let  $G$  be a group with a finite presentation  $\langle X | R \rangle$ , where  $|X| = g$  and  $|R| = r$ . Then there exists a symplectic 4-manifold  $Y$  such that  $\pi_1(Y) \cong G$ ,  $\chi(Y) = 12 + 8(r + g)$ ,  $\sigma(Y) = -8 - 4(g + r)$  and there exists a symplectic torus  $T \subset Y$  in a cusp neighborhood.*

*Proof.* Take fiber sum of  $N$  with the elliptic surface  $E(1)$  with at least two cusp fibers along  $T_0$  of  $N$  and a regular fiber of  $E(1)$ . This kills both generators  $t$  and  $s$  in the fundamental group of  $N$ . Then, take the fiber sum of  $N$  with  $g + r$  copies of  $P$  along  $T_i$ . Hence the classes represented by the curves  $\gamma_i$  die in the fundamental group by equation 3.4 and we get  $\pi_1(Y) = \langle X | R \rangle = G$ . Since  $\chi(N) = 0$ ,  $\chi(P) = 8$ ,  $\chi(E(1)) = 12$ ,  $\sigma(N) = 0$ ,  $\sigma(P) = -4$  and  $\sigma(E(1)) = -8$ , we obtain  $\chi(Y) = 12 + 8(r + g)$  and  $\sigma(Y) = -8 - 4(r + g)$ .  $\square$

## 3.2 The Manifold $S^1 \times M_K$

The following construction of the manifolds  $Y = S^1 \times M_K$ ,  $Y_n = S^1 \times M_{K_n}$  and the relevant computations in this section are from the paper of A. Akhmedov, R.Ī. Baykur and D. Park [1].

We begin with  $T^4 = (S^1)^4$ , rename the factors as  $a, b, c, d$  and define a symplectic structure on  $T^4 = (a \times b) \times (c \times d)$  as the product symplectic structure, where the symplectic structures on  $a \times b \cong T^2$  and  $c \times d \cong T^2$  are the standard symplectic structures described as the quotient  $T^2 = \mathbb{R}^2 / \mathbb{Z}^2$  with  $\omega_{\mathbb{R}^2} = dx \wedge dy$ , where the factors  $a, b$  and  $c, d$  correspond to the quotient of the axes  $x, y$  respectively. We will call the embedded loop  $a \times (0, 0, 0)$  also as  $a$ , and the related loops  $b, c, d \subset T^4$  accordingly.

Let  $\tilde{b}$  be a loop parallel to  $b$ . Let  $V_0$  be the result of  $-1$  Luttinger surgery on  $c \times \tilde{a}$  along  $\tilde{a}$  as described in Section 2.1.3, namely let  $V_0 = T^4(c \times \tilde{a}, \tilde{a}, -1)$ .

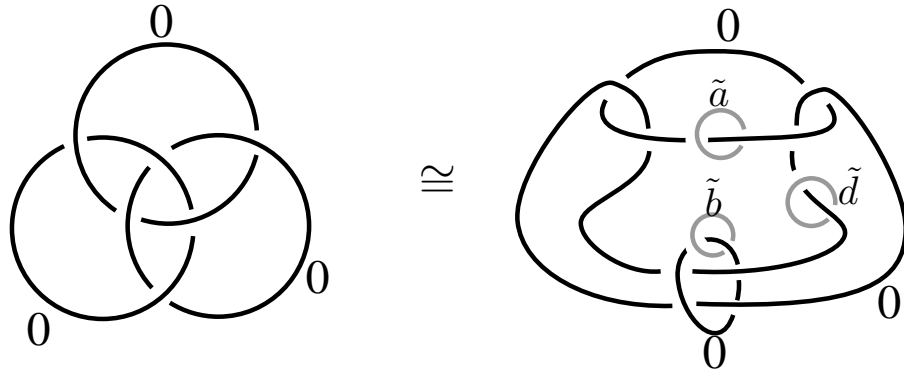

Figure 3.1: Dehn surgery diagram for  $T^3$ .

Similarly, let  $\tilde{b}$  be a parallel copy of  $b$  so that  $S^1 \times M_K = V_0(c \times \tilde{b}, \tilde{b}, -1)$ . Observe that normal discs to the tori lie completely in  $T^3 = a \times b \times d$ , thus we may consider these surgeries as Dehn surgeries with corresponding framings. In Figure 3.2, we apply these surgeries on  $T^3$ .

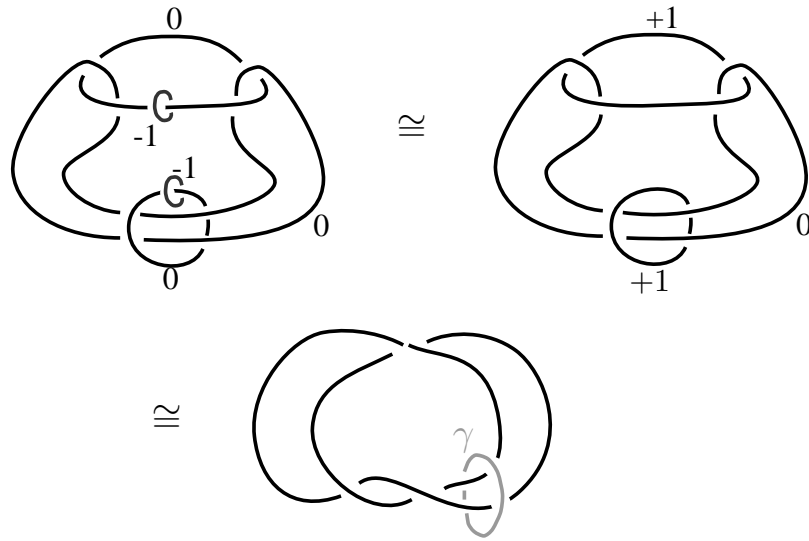

Figure 3.2: Surgery diagram for  $M_K$ .

Observe that the curve  $\gamma$  in Figure 3.2 can be homotoped to lie entirely in a Seifert surface of the 0-framed surgery knot so it is homologically trivial in  $M_K$ , hence also the torus  $\Gamma = c \times \gamma$  is homologically trivial in  $S^1 \times M_K$ . Also observe that -1 surgery on  $c \times \gamma$  along  $\gamma$  gives once-surgered manifold  $V_0$  back, which is



a symplectic manifold.

Now, instead of the  $-1$  surgery, let's apply  $-n$  surgery in the manifold  $V_0$  on  $L = c \times \tilde{b}$  along  $\tilde{b}$  and name this manifold as  $S^1 \times M_{K_n}$ . The corresponding Dehn surgery diagram is shown in Figure 3.3. Observe that doing a  $\frac{1}{n}$  surgery on  $\Lambda$  along  $\gamma$  yields the same manifold as applying  $-(n+1)$  surgery on  $c \times \tilde{b}$  along  $\tilde{b}$  in  $V_0$ , i.e.  $M_{K_{n+1}}$ .

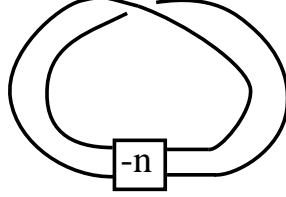

Figure 3.3: Surgery diagram for  $M_{K_n}$ .

The fundamental group of  $M_{K_n}$  can be obtained as follows: Consider the loop based at the marked point  $I$  in Figure 3.4, homotopic to  $[b^{-1}, d^{-1}]$ . By Equation 2.3,  $(-1)$ -surgery on  $c \times \tilde{a}$  along  $\tilde{a}$  creates the homotopy

$$[b^{-1}, d^{-1}]^{-1}a = 1. \quad (3.5)$$

Similarly,  $p/q$  surgery along  $\tilde{b}$  yields the relation

$$[a^{-1}, d]^{pb^q} = 1 \quad (3.6)$$

in the homotopy group. In our case,  $p = -1$  and  $q = 1$  thus we get the presentation

$$\pi_1(M_{K_n} \times S^1) = \langle a, b, d \mid a = [b^{-1}, d^{-1}], b = [a^{-1}, d]^n \rangle \oplus \mathbb{Z}_c \quad (3.7)$$

### 3.3 Construction of the Infinite Family of Non-Diffeomorphic Manifolds

We will first take the symplectic fiber sum of the symplectic manifold of Theorem 3.4 with  $S^1 \times M_K$  of Section 3.2 and then apply  $p/q$  surgery. Then, via Theorem 2.12 we will be able to tell that the resulting manifolds are non-

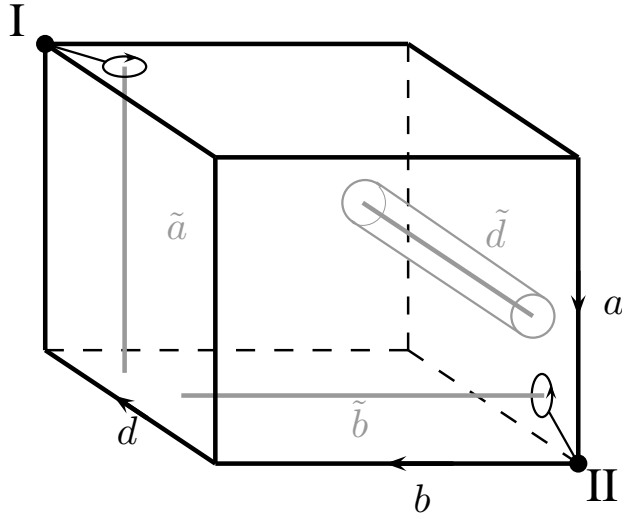

Figure 3.4

diffeomorphic. Consequently, Theorem 2.8 of I. Hambleton ([11]) will allow us to tell that an infinite family of these manifolds are homeomorphic.

Define  $G$  be a group with finite presentation and let  $Y$  be the symplectic manifold of Theorem 3.4 with  $\pi_1(Y)$ . Define  $X$  to be the symplectic fiber sum

$$X = Y \cup_{\psi} (S^1 \times M_K)$$

where  $\psi : T_1 \rightarrow T_2$  identifies the torus  $T_1 \subset X$  which is a regular fiber in the cusp neighborhood and  $T_2 = c \times \tilde{d} \subset S^1 \times M$ .

**Proposition 3.5.**  $\pi_1(X) = G$

*Proof.* The fiber sum identifies  $\partial(\nu T_1 \cong T^3)$  with  $\partial(\nu T_2) = T^3$  which is a trivial fiber bundle of parallel copies of  $c \times \tilde{d}$  fibered over the meridian  $\mu_{T_2} \cong [a, b]$ , identifying  $\mu_{T_1}$  with  $\mu_{T_2}$ .

Choose a base point  $y_0$  in  $Y$  away from  $T_1$ . The function  $\iota_* : \pi_1(Y \setminus \nu T_1, y_0) \rightarrow \pi_1(Y, y_0)$  is a surjection since any representative of an element of  $\pi_1(Y, y_0)$  is 1-dimensional so it can be homotoped so that it does not intersect with the 2-dimensional  $T_i$ , and hence can be pushed away from  $\nu T_1$ , so it also represents an element in  $\pi_1(Y \setminus \nu T_1, y_0)$ . Take a curve  $\gamma \subset Y \setminus \nu T_1$  such that  $[\gamma] \in \text{Ker } i_*$ , i.e.  $\gamma$  represents a trivial element in  $\pi_1(Y_0)$  so it bounds a 2-disk  $D$  in  $Y$  such that  $y_0 \in \partial D$ . We can choose this disk so that it intersects  $T_1$  transversally finitely many times. Thus  $\gamma \cong \mu_1^k$  in  $\pi_1(Y \setminus \nu T_1)$  for some  $k \in \mathbb{Z}$ . We conclude that  $\text{Ker } \iota_*$  is generated by  $\mu$  and hence  $\pi_1(Y \setminus \nu T_1) / \langle \mu_1 \rangle = \pi_1(Y)$ . By similar arguments we get  $\pi_1(S^1 \times M \setminus \nu T_2) / \langle \mu_2 \rangle = \pi_1(S^1 \times M)$

Let  $c'$  and  $d'$  be the generators of  $\pi_1(T_1)$  such that  $\psi(c') = c$  and  $\psi(d') = \tilde{d}$ . Push those generators onto a fiber in  $\partial(\nu T_i)$  (We will continue to denote these elements with the same letters). Now,  $\pi_1(\partial(\nu T_1)) = \mathbb{Z}_{c'} \oplus \mathbb{Z}_{d'} \oplus \mathbb{Z}_{\mu_1}$  and  $\pi_1(\partial(\nu T_2)) = \mathbb{Z}_c \oplus \mathbb{Z}_{\tilde{d}} \oplus \mathbb{Z}_{\mu_2}$ . Remember that  $T_1$  is in a cusp neighborhood so  $c'$  and  $d'$  are trivial in  $\pi_1(Y \setminus \nu T_1, y_0)$  and  $\mu_2 \cong [a, b]$  in  $\pi_1(S^1 \times M \setminus \nu T_2)$ . By Seifert-Van Kampen Theorem, we have

$$\pi_1(X) = [\pi_1(Y \setminus \nu T_1, y_0) * \pi_1(S^1 \times M \setminus \nu T_2)] / \langle [a, b] = \mu_1, c = 1, d = 1 \rangle. \quad (3.8)$$

Remember the relation  $a = [b^{-1}, d^{-1}]$  in  $\pi_1(S^1 \times M)$ . In figure 3.4, consider the dotted corner marked by  $I$  as the base point and observe that this homotopy is realized in the complement of the torus  $c \times d$ , hence it is still valid in  $\pi_1(S^1 \times M \setminus \nu T_2)$  and thus also in  $\pi_1(X)$ . Similarly, when we consider  $II$  as the base point, we see that  $b = [a^{-1}, d]$  holds in  $\pi_1(X)$  either. Hence in  $\pi_1(X)$ , we get the relation  $a = 1$  and  $b = 1$  since  $d = 1$ , and  $\mu_1 = [a, b] = 1$ . Therefore the second factor  $\pi_1(S^1 \times M \setminus \nu T_2)$  of the free product in equation 3.8 is totally killed by the quotient and  $\mu_1$  in  $\pi_1(Y \setminus \nu T_1, y_0)$  is killed, reducing this factor to  $\pi_1(Y)$ . As a result, we get  $\pi_1(X) = \pi_1(Y) = G$ .  $\square$

The signature of  $X$  is  $\sigma(X) = \sigma(Y) + \sigma(S^1 \times M_K) = \sigma(Y) = -8 - 4(g + r)$  by Novikov additivity, and the Euler characteristic of  $X$  can be computed as

$$\begin{aligned} \chi(X) &= \chi(Y \setminus \nu T_1) + \chi(S^1 \times M_K \setminus \nu T_2) + \chi(T^3) \\ &= \chi(Y) - \chi(T^2) + \chi(S^1 \times M_K) - \chi(T^2) + \chi(T^3) \\ &= \chi(Y) = 12 + 8(g + r) \end{aligned}$$

In section 3.2, we saw that the manifold  $S^1 \times M$  contains a torus  $\Lambda = c \times \gamma$  such that a parallel copy  $\gamma'$  is homologically trivial in  $S^1 \times M$ . The surface bounded by  $\gamma$  is disjoint from  $\tilde{d}$  so the torus is still homologically trivial in  $S^1 \times M \setminus \nu \Lambda$ . We also saw that zero surgery on this torus along  $\gamma$  gives a symplectic manifold. Since  $\Lambda$  has self intersection zero, we see that the conditions of theorem 2.12 are satisfied. Define the result of  $-n$  surgery on  $\Lambda$  in  $X$  along  $\gamma$  to be  $X_n = X_{\Lambda, \gamma}(1/n) = Y \cup_{\psi} S^1 \times M_{K_n}$ . Applying Theorem 2.12 on  $X$ , we obtain the following result:

**Theorem 3.6.** *Given any group  $G$  with finite presentation with  $g$  generators and  $r$  relations, there exists family of smooth manifolds  $\{X_n : n \in \mathbb{N}\}$  such that  $\chi(X_n) = 12 + 8(g + r)$ , which includes an infinite subfamily of pairwise non-diffeomorphic manifolds.*

If we choose the group  $G$  to be finite, then we can apply Theorem 2.8 to this family. The theorem tells that each of the manifolds in the infinite family subfamily of non-diffeomorphic submanifolds given in Theorem 3.6 are distributed into classes of a finite number of topological types and thus there exists an infinite subfamily  $\{X_{n_k}\}_{k \in \mathbb{N}}$  of pairwise homeomorphic manifolds, hence we get the following theorem:

**Theorem 3.7.** *Given a finite group  $G$  there exists an infinite family of pairwise non-diffeomorphic smooth 4-manifolds with the same topological type. If  $G$  has a presentation with  $g$  generators and  $r$  relations, then the manifolds has Euler characteristic  $\chi = 12 + 8(g + r)$ .*

### Comparison of Euler Characteristics with manifolds of J. Park

As cited in Theorem 3.1, J. Park has constructed infinite families of exotic smooth manifolds for arbitrary finite fundamental group and for certain regions of  $(\chi_h, c_1^2)$  plane ([15]). The constants  $r_G$  and  $t_G$  in Theorem 3.1 are  $r_G = \frac{p(m)}{q(m)}$  and  $t_G = q(m)$ , where  $p(m) = 225m^2 + 1148m + 1413$ ,  $q(m) = 25m^2 + 143.5m + 181.5 + g + r$ ,  $g$  and  $r$  being the number of generators and relations for a presentation of  $G$  and  $m \geq 1$  is an arbitrary odd integer. Since  $\chi(X) = 12\chi_h(X) - c_1^2$  and a manifold of J. Park satisfies  $\chi_h(X) \geq q(m)$  and  $0 \leq c_1^2(X) \leq \chi_h(X) \frac{p(m)}{q(m)}$ , we get

$$\begin{aligned} \chi(X) &= 12\chi_h(X) - c_1^2 \\ &\geq 12\chi_h(X) - \frac{p(m)}{q(m)}\chi_h(X) = \chi_h(X) \left( 12 - \frac{p(m)}{q(m)} \right) . \end{aligned}$$

We observe that  $12q(m) > p(m)$  for any  $m \geq 1$ , so  $12 - \frac{p(m)}{q(m)}$  is positive, hence

$$\begin{aligned} \chi(X) &\geq q(m) \left( 12 - \frac{p(m)}{q(m)} \right) = 12q(m) - p(m) \\ &\geq 75m^2 + 574m + 765 + 12(g + r) \geq 1414 + 12(g + r) . \end{aligned}$$

We see that the manifolds of J. Park are bigger than the manifolds we constructed in the sense of Euler characteristics.

# CHAPTER 4

## EXOTIC MANIFOLDS WITH CYCLIC FUNDAMENTAL GROUP OF ODD ORDER

In this chapter we will construct a pair of small homeomorphic but non-diffeomorphic symplectic manifolds with cyclic fundamental groups of any odd order. Our construction will follow the method developed by A. Akhmedov for constructing small exotic 4-manifolds. The method involves gluing small symplectic manifolds like  $T^4 = T^2 \times T^2$  and  $S^2 \times T^2$  and applying surgery on Lagrangian tori in them. A crucial point is that the order of these gluing and surgery operations will not matter since the loci they are applied will be away from each other.

### 4.1 Construction Scheme

The construction uses methods and computations from the article [1] of A. Akhmedov, R.İ. Baykur and D. Park where infinite families of small exotic simply connected manifolds are constructed. We will alter the constructions to obtain non-trivial fundamental groups.

First we will construct an irreducible manifold  $M$  for which we try to obtain an exotic copy. We will tell the difference in smooth structures by irreducibility. The exotic copy will be non-minimal, i.e. it will be in the form  $N\sharp m\overline{\mathbb{C}\mathbb{P}^2}$  for some symplectic manifold  $N$  and  $m \geq 1$ .

The topological classification theorems of Section 2.2 tells that the homeomorphism type of a smooth manifold with a particular cyclic fundamental group of odd order is determined by its signature, parity and Euler characteristic. Thus the manifold  $N$  should have cyclic fundamental group of the same order with

$M$  and satisfy  $\chi(N\#m\overline{\mathbb{C}\mathbb{P}^2}) = \chi(M)$  and  $\sigma(N\#m\overline{\mathbb{C}\mathbb{P}^2}) = \sigma(M)$ , or equivalently  $\chi(N) = \chi(M) - m$  and  $\sigma(N) = \sigma(M) + m$ .

An important part of the procedure is to keep track of how the fundamental group is affected by the surgery operations.

## 4.2 Exotic Manifolds with Cyclic Fundamental Groups of Odd Order

In this section, we will try to obtain a symplectic manifold with finite cyclic fundamental group which includes an appropriate Lagrangian torus so that we can apply the necessary Luttinger surgeries.

Consider  $T^4 = T^2 \times T^2$  and  $S^2 \times T^2$  with symplectic structures induced by the product. In  $T^2 \times T^2$ , let  $A = T^2 \times \{y\}$  and  $B = \{x\} \times T^2$  for some  $x, y \in T^2$ . The tori  $A$  and  $B$  intersect transversally at the single point  $(x, y)$ , so the homology class  $[A] + [B] \in H_2(T^2 \times T^2; \mathbb{Z})$  is represented by a singular surface of genus two which has self-intersection 2. If we blow up  $T^2 \times T^2$  at this self intersection points and resolve the singularity symplectically, we obtain  $Y = T^4 \# 2\mathbb{C}\mathbb{P}^2$  in which the genus two surface above transforms into a smooth genus two surface  $\Sigma$  of self intersection zero.

The generators of the fundamental group of  $Y$  can be obtained via the inclusion  $\Sigma \hookrightarrow Y$ . The fundamental group is

$$\begin{aligned} \pi_1(Y) &= \langle a, b, c, d \mid [a, b] = [a, c] = [a, d] = [b, c] = [b, d] = [c, d] = 1 \rangle \\ &\cong \mathbb{Z}^4 . \end{aligned}$$

where  $a, b, c, d$  are the generators of  $\pi_1(\Sigma)$ . Choose these generators to be Lagrangian in the corresponding  $T^2$  factor of  $T^2 \times T^2$ .

Secondly, consider  $S^2 \times T^2$ , again with its product symplectic structure. Take the union of two parallel copies of  $T^2$  and a copy of  $S^2$ , namely for  $x_1, x_2 \in S^2$  and  $y \in T^2$  take  $(\{x_1\} \times T^2) \cup (\{x_2\} \times T^2) \cup (S^2 \times \{y\})$ . Now,  $\{x_i\} \times T^2$  and  $S^2 \times \{y\}$  intersect transversally once so the surface representing the same homology class has self intersection four. Thus we blow up this manifold at four points and resolve the singularities symplectically to obtain  $Z = S^2 \times T^2 \# 4\mathbb{C}\mathbb{P}^2$  and a symplectic

surface  $\Sigma' \subset Z$  of genus two and self intersection zero. The fundamental group of  $Z$  can be presented as

$$\pi_1(Z) = \langle x, y \mid [x, y] = 1 \rangle \cong \mathbb{Z}^2.$$

Consider the inclusion  $\Sigma' \hookrightarrow Z$ . Choose the generators  $a', b', c', d'$  of  $\pi_1(Z)$  so that the inclusion map  $\iota : \Sigma' \hookrightarrow Z$  identifies the generators of the fundamental group as

$$\iota_*(a') = x, \quad \iota_*(b') = x^{-1}, \quad \iota_*(c') = y, \quad \iota_*(d') = y^{-1}.$$

Besides, note that the meridian  $\mu'$  to  $\Sigma'$  is homotopically trivial in  $\pi_1(Z \setminus \nu\Sigma')$  since  $\Sigma$  intersects an exceptional sphere (in fact, all four of them) transversally once. Therefore, by the same arguments as in the proof of Proposition 3.3, the map  $\iota_* : \pi_1(Z \setminus \nu\Sigma') \rightarrow \pi_1(Z)$  induced by the inclusion  $\iota : Z \setminus \nu\Sigma' \hookrightarrow Z$  is a surjection and its kernel is generated by  $\mu' = 1$ , hence it is an isomorphism. Consequently,  $\pi_1(Z \setminus \nu\Sigma') \cong \pi_1(Z) = \mathbb{Z}_x \oplus \mathbb{Z}_y$

Now, we exclude the neighborhoods of  $\Sigma$  and  $\Sigma'$  from  $Y$  and  $Z$  respectively and construct the symplectic fiber sum

$$\tilde{M} = (Y \setminus \nu\Sigma) \cup_{\phi} (Z \setminus \nu\Sigma')$$

by a map  $\phi$  which sends  $a \mapsto a', b \mapsto b', c \mapsto c', d \mapsto d'$ . By Seifert-Van Kampen theorem we obtain

$$\begin{aligned} \pi(\tilde{M}) = \langle a, b, c, d, x, y \mid [a, b] = [a, c] = [a, d] = [b, c] = [b, d] = [c, d] = 1, \\ [x, y] = 1, a = x, b = y, c = x^{-1}, d = y^{-1} \rangle = \langle x, y \mid [x, y] = 1 \rangle \\ \cong \mathbb{Z}^2. \end{aligned}$$

Direct computation yields

$$e(Y) = 0 \cdot 0 + 2 = 2, \quad e(Z) = 2 \cdot 0 + 4 = 4$$

and hence

$$e(\tilde{M}) = 2 + 4 - 2e(\Sigma) = 6 - 2(-2) = 10.$$

Besides, it is also easy to observe that

$$\sigma(Y) = \sigma(T^4) - 2 = 0 - 2 \text{ and } \sigma(Z) = -4$$

thus  $\sigma(\tilde{M}) = -2 - 4 = -6$ . Since  $e(\tilde{M}) = 10$  and  $H_1(\tilde{M}, \mathbb{Z}) \cong \pi_1(\tilde{M}) \cong \mathbb{Z}^2$ , we obtain

$$b_2(\tilde{M}) = e(\tilde{M}) + 2b_1(M) - 2 = 10 + 2 \cdot 2 - 2 = 12 .$$

Now let's return to  $Y = T^2 \times T^2 \# 2\mathbb{C}\mathbb{P}^2$ . Let  $\tilde{a}$  and  $\tilde{b}$  parallel Lagrangian copies of  $a$  and  $b$  in  $T^2$  respectively. Then  $\tilde{a} \times c$  and  $\tilde{b} \times c$  are Lagrangian tori in  $T^4$ . Since both the blow-ups and gluing with  $Z$  occur away from these two tori, we can apply Luttinger surgery to  $T^4$  on these tori first and then glue up, instead of applying them to directly  $\tilde{M}$ . We will call the manifold obtained after surgeries on  $\tilde{M}$  as  $M$ .

Choose  $n$  to be an odd natural number. We apply  $-1$  Luttinger Surgery on  $T_1 = \tilde{a} \times c$  along  $\tilde{a}$  and  $1/n$  Luttinger Surgery on  $T_2 = \tilde{b} \times c$  along  $\tilde{b}$ . Call the resulting manifold as  $X$ . By Equations 3.5 and 3.6 we have the relations

$$a = [b^{-1}, d^{-1}] , b^n = [d^{-1}, a]$$

in  $\pi_1(X)$ . Also note that the meridian  $\mu$  of  $\Sigma$  is homotopic to  $[a, b]$  in  $X \setminus \nu\Sigma$ , and again,  $\mu$  generates the kernel of the surjection  $\iota_* : \pi_1(Y \setminus \nu\Sigma) \rightarrow \pi_1(Y)$ . Since  $\Sigma$  also intersects the exceptional spheres, we get  $\mu = [a, b] = 1$  and thus  $\pi_1(X \setminus \nu\Sigma) \cong \pi_1(X)$ .

Now, let's compute  $\pi_1(M)$  by Seifert-Van Kampen Theorem:

$$\begin{aligned} \pi_1(M) &= \pi_1(X \setminus \nu\Sigma) * \pi_1(Z \setminus \nu\Sigma') / \langle a = x, b = y, c = x^{-1}, d = y^{-1} \rangle \\ &= \pi_1(X) * \pi_1(Z) / \langle a = x, b = y, c = x^{-1}, d = y^{-1} \rangle \\ &= \langle a, b, c, d, x, y, | a = [b^{-1}, d^{-1}] , b^n = [d^{-1}, a], [x, y] = 1, \\ &\quad a = x, b = y, c = x^{-1}, d = y^{-1} \rangle . \end{aligned}$$

If we reduce the number of generators by replacing  $x = a, y = b, c = a^{-1}, d = b^{-1}$  we get:

$$\pi_1(M) = \langle a, b | a = [b^{-1}, b], b^n = [b, a], [a, b] = 1 \rangle$$



from which we see that  $a = [b^{-1}, b] = 1$  and thus  $b$  is the only generator and  $b^n = [b, a] = 1$  is the only relation that survives, yielding  $\pi_1(M) = \langle b \mid b^n = 1 \rangle \cong \mathbb{Z}_n$ . Since the only operations we applied are symplectic fiber sum and Luttinger surgeries, the resulting manifold we obtained is a symplectic manifold.

A symplectic manifold is said to be *minimal* if it does not contain any  $(-1)$ -spheres, i.e. a sphere with self intersection  $-1$ . The following theorem of M. Usher offers a way to prove a symplectic manifold is minimal:

**Theorem 4.1** ([19]). *Let  $R$  be the symplectic fiber sum of the manifolds  $A$  and  $B$  on surfaces  $\Sigma \subset A$  and  $\Sigma' \subset B$  with genus  $g > 0$ . Then*

- (i) *If  $A \setminus \Sigma$  or  $B \setminus \Sigma'$  contains a  $(-1)$ -sphere then  $R$  is not minimal.*
- (ii) *If one of the summands admits  $S^2$ -fibration on a genus  $g$  surface such that the gluing surface is a section, then  $R$  is minimal if and only if the other summand is minimal.*
- (iii) *In all other cases,  $R$  is minimal.*

In particular, if the complements of the gluing surfaces does not contain any  $(-1)$ -spheres and if neither of the summands admits a fibration as described in Theorem 4.1 then the manifold in question is minimal. Let's consider the manifold  $M$ . Since  $\Sigma$  and  $\Sigma'$  intersect the only  $(-1)$ -spheres of the summands, the complements  $X$  and  $Z$  has no  $(-1)$ -spheres. Also, since the summands have Euler characteristics 2 and 4, and since an  $S^2$  fibration over a surface of genus two should have  $2 \cdot (-2) = -4$  as Euler characteristic, the summands cannot have the fibration structure as described. consequently, the manifold  $M$  is minimal.

An smooth manifold  $R$  is *irreducible* if  $R = A \natural B$  implies  $A = S^4$  or  $B = S^4$ . The following theorem allows us to pass from minimality to irreducibility for a wide class of manifolds, including all manifolds with a finite fundamental group. As a result of this theorem, our manifold  $M$  is irreducible.

**Theorem 4.2** ([12]). *Any minimal symplectic manifold with residually finite fundamental group is irreducible.*

Next, we will construct another symplectic manifold  $N$  which will be blown-up to give an exotic copy of  $M$ . We now start with two copies of  $T^4 \natural 2\overline{\mathbb{C}\mathbb{P}^2}$ . We call the first copy as  $Y$  and the second copy as  $Y'$ . The generators  $a, b, c, b \in \pi_1(Y)$

retain their names, and the corresponding generators of  $\pi_1(Y')$  will be denoted by  $a', b', c'$  and  $d'$ , respectively. Again, we consider the symplectic genus two surface  $\Sigma \subset Y$  and name its copy in  $Y'$  as  $\Sigma'$ . Define the symplectic fiber sum of  $Y$  and  $Y'$  on  $\Sigma$  as

$$\tilde{N} = (Y \setminus \nu\Sigma) \cup_{\psi} (Y' \setminus \nu\Sigma')$$

such that  $\psi : \partial(\nu\Sigma) \rightarrow \partial(\nu\Sigma')$  satisfies

$$\psi(a) = c' , \psi(b) = d' , \psi(c) = a' , \psi(d) = b'. \quad (4.1)$$

The Euler characteristic and signature of  $\tilde{N}$  is computed as

$$\chi(\tilde{N}) = \chi(Y) + \chi(Y') - 2\chi(\nu\Sigma) = 2 + 2 - 2(-2) = 8$$

$$\sigma(\tilde{N}) = \sigma(Y) + \sigma(Y') = -2 - 2 = -4$$

Observe that  $\chi(\tilde{N}) = 8 = \chi(M) - 2$  and  $\sigma(\tilde{N} \# 2\overline{\mathbb{C}\mathbb{P}^2}) = -4 = \sigma(M) + 2$ . Now, we again apply  $-1$  Luttinger Surgery on  $T_1 = \tilde{a} \times c$  along  $\tilde{a}$  and  $1/n$  Luttinger Surgery on  $T_2 = \tilde{b} \times c$  along  $\tilde{b}$  in  $Y$ . In the second copy, apply  $-1$  Luttinger surgeries on  $T'_1 = \tilde{a}' \times c$  along  $\tilde{a}'$  and  $T'_2 = \tilde{b}' \times c$  along  $\tilde{b}'$ . In other words, we replace  $Y$  by  $X$  in  $\tilde{N}$ , and we call the resulting manifold as  $N$ . Let  $\mu = [a, b]$  denote the meridian of  $\Sigma$  and  $\mu' = [c', d'] = 0$  denote the meridian of  $\Sigma'$  (To see that  $[c, d]$  is also a meridian of  $\Sigma$ , just interchange the roles of the pairs  $a, b$  and  $c, d$  in Figure 3.4). The fundamental group of  $N$  is

$$\pi_1(N) = \pi_1(X \setminus \nu\Sigma) * \pi_1(X' \setminus \nu\Sigma') / \langle a = c', b = d', c = a', d = b', \rangle .$$

Note that the relations  $[a, c] = 1$  and  $[b, c] = 1$  still hold in  $\pi_1(X \setminus \nu\Sigma)$ , hence in  $\pi_1(N)$ . We also have  $[a, b] = 1$  and  $[c, d] = 1$  by triviality of meridian  $\mu$ , and we have the relations  $a = [d^{-1}, b^{-1}]$  and  $b^n = [a, d^{-1}]$  from the surgeries. Similarly,  $[a', c'] = 1, [b', c'] = 1, a' = [d'^{-1}, b'^{-1}]$  and  $b' = [a', d'^{-1}]$  hold in  $\pi_1(Y' \setminus \nu\Sigma')$ . We replace primed generators from  $Y'$  in relations by Equations 4.1 and obtain  $[c, a] = [d, a] = 1, c = [b^{-1}, d^{-1}]$  and  $d = [c, b^{-1}]$  in  $\pi_1(N)$ . Observe that  $c = a^{-1}$  can be obtained by  $a = [d^{-1}, b^{-1}]$  and  $c = [b^{-1}, d^{-1}]$ . Since  $[a, b] = 1$  (i.e.  $a$  and  $b$  commute) we obtain  $d = [a^{-1}, b^{-1}] = 1$ . Since we know that  $d = 1$ , we have  $a = [d^{-1}, b^{-1}] = 1$  and thus  $c = a^{-1} = 1$ . The only generator that survives is  $b$

with the relation  $b^n = [a, d^{-1}] = 1$ . We conclude that  $\pi_1(N) \cong \mathbb{Z}_n$ . Note that the Luttinger surgeries and symplectic fiber sums preserve symplecticity, so the resulting manifold  $N$  is symplectic.

The Euler characteristic and signature of  $\tilde{N}$  does not change by  $p/q$ -surgery, hence  $\chi(N) = 8$  and  $\sigma(N) = 4$  either. Thus  $\chi(N\#2\overline{\mathbb{C}\mathbb{P}^2}) = 8 + 2 = 10 = \chi(M)$  and  $\chi(N\#2\overline{\mathbb{C}\mathbb{P}^2}) = -4 - 2 = -6 = \chi(M)$ . Since the fundamental groups are also isomorphic, by Theorem 2.7 we conclude that  $M$  and  $N\#2\overline{\mathbb{C}\mathbb{P}^2}$  are homeomorphic. But they are not diffeomorphic since  $M$  is irreducible but  $N\#2\overline{\mathbb{C}\mathbb{P}^2}$  is not. Hence  $N\#2\overline{\mathbb{C}\mathbb{P}^2}$  is an exotic copy of the manifold  $M$ .

## REFERENCES

- [1] A. Akhmedov, R.Ī. Baykur, D. Park, “Constructing infinitely many smooth structures on small 4-manifolds”, *J. Topol.* **1** (2008), 409–428.
- [2] D. Auroux, S.K. Donaldson, L. Katzarkov, “Luttinger Surgery along Lagrangian Tori and Non-isotopy for Singular Symplectic Plane Curves”, *Math. Ann.* **326** (2003), 185–203.
- [3] S. Baldridge, P. Kirk, “Construction of small symplectic 4-manifolds using Luttinger surgery”, *J. Differential Geom.* **82** (2009), 317–361.
- [4] S. Baldridge, P. Kirk, “An interesting symplectic 4-manifold with small Euler characteristic”, arXiv:math/0701400.
- [5] S. Baldridge, P. Kirk, “On symplectic 4-manifolds with prescribed fundamental group”, *Comment. Math. Helv.* **82** (2007), 845–875.
- [6] R. Fintushel, R.J. Stern, “Nondiffeomorphic symplectic 4-manifolds with the same Seiberg-Witten Invariants”, in *Proceedings of the Kirbyfest (Berkeley, CA, 1998)*, 103–111 (electronic), *Geom. Topol. Publ.*, Coventry, 1999;
- [7] R. Fintushel, R.J. Stern, N. Sunukjian, “Exotic group actions on simply connected smooth 4-manifolds”, *J. Topol.* **2** (2009), no. 4, 769–778.
- [8] R. Fintushel, B.D. Park, R.J. Stern, “Reverse engineering small 4-manifolds”, *Algebraic & Geometric Topology* **7** (2007) 2103–2116.
- [9] M. Freedman, “The topology of four-dimensional manifolds”, *J. Diff. Geom.*, **17** (1982), 357–453.
- [10] R.E. Gompf, A.I. Stipsicz, *4-Manifolds and Kirby Calculus*, American Mathematical Society, 1999
- [11] I. Hambleton, M. Kreck, “On the Classification of Topological 4-Manifolds with Finite Fundamental Group”, *Mathematische Annalen*, **280** (1988) 85–104.

- [12] M.J.D. Hamilton, D. Kotschick, “Minimality and irreducibility of symplectic four-manifolds”, *Internat. Math. Res. Not.* 2006, Art. ID 35032, pp. 13.
- [13] K.M. Luttinger, “Lagrangian tori in  $\mathbb{R}^4$ ”, *J. Diff. Geom.* **42** (1995), 220–228.
- [14] J.W. Morgan, T.S. Mrowka, Z. Szabo “Product formulas along  $T^3$  for Seiberg-Witten invariants”, *Math. Res. Lett.* **4** (1997), 915–929.
- [15] J. Park “The geography of symplectic 4-manifolds with an arbitrary fundamental group”, *Proc. Amer. Math. Soc.* **135** (2007), no. 7, 2301–2307 (electronic).
- [16] C. Taubes, “The Seiberg-Witten invariants and symplectic forms”, *Math. Res. Letters* **1** (1994) 809–882.
- [17] W. Thurston, “Some simple examples of symplectic manifolds”, *Proc. Amer. Math. Soc.* **55** (1976), 467–468.
- [18] M. Ue, “Exotic group actions in dimension four and Seiberg-Witten theory”, *Proc. Japan Acad. Ser. A Math. Sci.* **74** (1998) 68–70.
- [19] M. Usher, “Minimality and symplectic sums”, *Internat. Math. Res. Not.* 2006, Art. ID 49857, pp. 17.
- [20] E. Witten, “Monopoles and four-manifolds”, *Math. Res. Letters* **1** (1994) 769–796.

# VITA

## PERSONAL INFORMATION

Surname, Name: Topkara, Mustafa  
Nationality: Turkish (T. C.)  
Date and Place of Birth: 29 October 1979, İstanbul  
Marital Status: Single  
email: m.e.topkara@gmail.com

## EDUCATION

Degree	Institution	Year of Graduation
MS	METU, Mathematics	2004
BS	METU, Mathematics	2001
High School	Kadıköy Anadolu Lisesi	1997

## WORK EXPERIENCE

Year	Place	Enrollment
2001-2008	METU, Mathematics	Research Assistant
2009-...	MSGSÜ, Mathematics	Instructor

## FOREIGN LANGUAGE

English (fluent)