

A COMPLEX DYNAMICAL SYSTEMS MODEL OF EDUCATION, RESEARCH,  
EMPLOYMENT, AND SUSTAINABLE HUMAN DEVELOPMENT

A THESIS SUBMITTED TO  
THE GRADUATE SCHOOL OF NATURAL AND APPLIED SCIENCES  
OF  
MIDDLE EAST TECHNICAL UNIVERSITY

BY

EZGİ ERDOĞAN

IN PARTIAL FULFILLMENT OF THE REQUIREMENTS  
FOR  
THE DEGREE OF MASTER OF SCIENCE  
IN  
INDUSTRIAL ENGINEERING

JUNE 2010

Approval of the thesis:

**A COMPLEX DYNAMICAL SYSTEMS MODEL OF EDUCATION, RESEARCH,  
EMPLOYMENT, AND SUSTAINABLE HUMAN DEVELOPMENT**

submitted by **EZGİ ERDOĞAN** in partial fulfillment of the requirements for the degree of  
**Master of Science in Industrial Engineering Department, Middle East Technical University** by,

Prof. Dr. Canan Özgen  
Dean, Graduate School of **Natural and Applied Sciences** \_\_\_\_\_

Prof. Dr. Nur Evin Özdemirel  
Head of Department, **Industrial Engineering** \_\_\_\_\_

Prof. Dr. Meral Azizoğlu  
Supervisor, **Industrial Engineering Dept., METU** \_\_\_\_\_

Prof. Dr. Sencer Yeralan  
Co-supervisor, **Agricultural and Biological Engineering Dept., UFL** \_\_\_\_\_

**Examining Committee Members:**

Prof. Dr. Sencer Yeralan  
Agricultural and Biological Engineering Dept., UFL \_\_\_\_\_

Prof. Dr. Meral Azizoğlu  
Industrial Engineering Dept., METU \_\_\_\_\_

Assoc. Prof. Dr. Derek Baker  
Mechanical Engineering Dept., METU \_\_\_\_\_

Assoc. Prof. Dr. Erdinç Sayan  
Philosophy Dept., METU \_\_\_\_\_

Assoc. Prof. Dr. Tayyar Şen  
Industrial Engineering Dept., METU \_\_\_\_\_

**Date:** \_\_\_\_\_

**I hereby declare that all information in this document has been obtained and presented in accordance with academic rules and ethical conduct. I also declare that, as required by these rules and conduct, I have fully cited and referenced all material and results that are not original to this work.**

Name, Last Name: EZGİ ERDOĞAN

Signature :

## ABSTRACT

### A COMPLEX DYNAMICAL SYSTEMS MODEL OF EDUCATION, RESEARCH, EMPLOYMENT, AND SUSTAINABLE HUMAN DEVELOPMENT

Erdoğan, Ezgi

M.S., Department of Industrial Engineering

Supervisor : Prof. Dr. Meral Azizoğlu

Co-Supervisor : Prof. Dr. Sencer Yeralan

June 2010, 113 pages

Economic events of this era reflect the fact that the value of information and technology has surpassed the value of physical production. This motivates countries to focus on increasing the education levels of citizens. However, policy making about education system and its returns requires dynamical analyses in order to be sustainable. The study aims to investigate the dynamic characteristics of a country-wide education system, in particular, that of Turkey. System Dynamics modeling, which is one of the most commonly referred tools for understanding the complex social structures, is used. Our model introduces dynamic relationships among different classes of labor forces with varying education levels, university admissions, research quality, and the investments made in education, research and other sectors. Model experimentation provides new insights into the investment and capacity-related aspects of the education system environment.

Keywords: system dynamics, dynamic modeling, complex systems, education and economic growth, education system

## ÖZ

### EĞİTİM, ARAŞTIRMA, İSTİHDAM VE SÜRDÜRÜLEBİLİR İNSANİ GELİŞİMİN KARMAŞIK BİR DİNAMİK SİSTEMLER MODELİ

Erdoğan, Ezgi

Yüksek Lisans, Endüstri Mühendisliği Bölümü

Tez Yöneticisi : Prof. Dr. Meral Azizoglu

Ortak Tez Yöneticisi : Prof. Dr. Sencer Yeralan

Haziran 2010, 113 sayfa

Son zamanlardaki ekonomik etkinlikler, bilgi ve teknolojinin değerinin, fiziksel üretimin değerini geride bıraktığını yansıtmaktadır. Bu durum ülkeleri, yurttaşlarının eğitim düzeylerini arttırmaya odaklanmalarına teşvik etmektedir. Ancak, eğitim sistemi ve onun getirileri hakkında sürdürülebilir politikalar üretmek, dinamik analizler gerektirir. Bu çalışmanın amacı, Türkiye özelinde, ülke çapındaki bir eğitim sisteminin dinamik özelliklerini incelemektir. Karmaşık sosyal yapıların anlaşılması için en sık başvurulan araçlardan biri olan Sistem dinamiği modellenmesi kullanılmıştır. Modelimiz farklı eğitim düzeylerine sahip çalışan grupları, üniversite kabulü, araştırma kalitesi, ve eğitim, araştırma ve diğer sektörlere yapılan yatırımlar arasındaki dinamik ilişkileri ortaya koymaktadır. Model deneyleri, eğitim sistemi çerçevesinde, yatırım ve kapasite ile ilgili konularda yeni görüşler sunar.

Anahtar Kelimeler: sistem dinamikleri, dinamik modelleme, karmaşık sistemler, eğitim ve ekonomik büyüme, eğitim sistemi

*To the future*

## ACKNOWLEDGMENTS

First of all, I am heartily thankful to Prof. Dr. Sencer Yeralan, for his valuable intellectual contributions, support and generosity that will never be forgotten. It was a big chance for me to be the student of such a visionary advisor, who has reshaped my thinking and has been a model for me.

I would like to thank Prof. Dr. Meral Azizođlu for her wise advices and being insightful since my first day in the Industrial Engineering Department.

I should express my thanks to the committee members Assoc. Prof. Dr. Derek Baker, Assoc. Prof. Dr. Erdiñ Sayan, and Assoc. Prof. Dr. Tayyar Ően for their significant and meticulous criticisms.

I am also greatly indebted to many teachers in the past.

I would like to thank Sercan Oruđ and Mehtap Demir for their sharings and discussions.

I would like to offer my acknowledgements to all my friends and loved ones near or far, all of whom stated their trust. Out of them, I would like to single out Buse okoy, elebi Kocair and Ezgi Erođlu for their technical or logistic support.

I would love to express my appreciation to ađatay allı who was always there for me to share the most challenging times of the process by imposing self confidence. Without his help, patience, and caring, this thesis wouldn't be completed.

Finally, I owe my deepest gratitude to my parents Feride Erdođan and Mustafa Erdođan for their unending love, trust and unconditional support to pursue my education.

# TABLE OF CONTENTS

ABSTRACT . . . . .	iv
ÖZ . . . . .	v
DEDICATON . . . . .	vi
ACKNOWLEDGMENTS . . . . .	vii
TABLE OF CONTENTS . . . . .	viii
LIST OF TABLES . . . . .	xi
LIST OF FIGURES . . . . .	xii
LIST OF ABBREVIATIONS . . . . .	xvi
CHAPTERS	
1 INTRODUCTION . . . . .	1
2 METHODOLOGY: SYSTEM DYNAMICS . . . . .	5
2.1 Evolution and Principles . . . . .	5
2.2 Structure of System Dynamics Modeling . . . . .	7
2.2.1 Feedback Loops . . . . .	7
2.2.2 Building Blocks . . . . .	8
2.2.3 Mathematical Relations . . . . .	9
2.2.4 Stages of System Dynamics Modeling . . . . .	9
3 LITERATURE SURVEY . . . . .	11
4 INDICATORS OF EDUCATION-DEVELOPMENT RELATIONSHIPS . . . . .	16
4.1 Returns on Education . . . . .	16
4.2 Over-Education Theory . . . . .	18
4.3 Turkey's Status . . . . .	18
4.4 A Brief Summary of Science and Technology Policies in Turkey . . . . .	19



5	MODEL FORMULATION AND ANALYSIS . . . . .	21
5.1	Problem Conceptualization . . . . .	21
5.1.1	System Boundaries . . . . .	21
5.1.2	The Causal Loop-Influence Diagram . . . . .	22
5.2	The Model . . . . .	24
5.2.1	The Education Process Sector . . . . .	24
5.2.2	The Labor Sector . . . . .	26
5.2.3	The Education Quality Sector . . . . .	27
5.2.4	The Research Sector . . . . .	29
5.2.5	The Output Sector . . . . .	30
5.2.6	The Budget Sector . . . . .	32
5.2.7	The Jobs Sector . . . . .	34
5.2.8	The Population Sector . . . . .	35
5.3	Model Execution . . . . .	35
5.4	Data . . . . .	36
5.5	Verification and Validation . . . . .	36
5.6	The Model Utility . . . . .	38
5.7	Policy Formulation and Experimentation . . . . .	39
5.7.1	Base-Run (No policy alternative) . . . . .	39
5.7.2	Alternative Scenarios . . . . .	40
5.7.2.1	Single Policy Alternatives . . . . .	40
5.7.2.2	Combined Policy Analysis . . . . .	56
6	DISCUSSION AND CONCLUSION . . . . .	61
	REFERENCES . . . . .	63
	APPENDICES	
A	MODEL VARIABLES . . . . .	68
A.1	Stocks . . . . .	68
A.2	Flows . . . . .	69
A.3	Converters . . . . .	71
B	MODEL EQUATIONS . . . . .	73

C	SENSITIVITY ANALYSIS . . . . .	83
D	EXTREME CONDITIONS TEST . . . . .	103
E	EFFICIENCY MULTIPLIER COMPONENTS RELATIVE WEIGHT ANAL- YSIS . . . . .	112

## LIST OF TABLES

### TABLES

Table 5.1 Simulation Time vs. Real Time . . . . .	36
Table A.1 Stocks . . . . .	68
Table A.2 Flows . . . . .	69
Table A.3 Flows - 2 . . . . .	70
Table A.4 Converters . . . . .	71
Table A.5 Converters - 2 . . . . .	72

## LIST OF FIGURES

### FIGURES

Figure 1.1	Waves of Innovation [12]. . . . .	1
Figure 1.2	Three Dimensions of Sustainable Development [30]. . . . .	2
Figure 2.1	Illustrative Growth Model for a New Established Restaurant . . . . .	8
Figure 2.2	Basic Building Blocks of System Dynamics Modeling . . . . .	9
Figure 2.3	Phases of Systems Thinking and Modeling Methodology [88]. . . . .	10
Figure 4.1	Research and Development Expenditure per Capita (Thousands of US dollars. Source: OECD. Data up to and including 2003) . . . . .	19
Figure 5.1	Model Sectors and Their Interactions . . . . .	23
Figure 5.2	The Causal Loop Diagram of the Model . . . . .	23
Figure 5.3	The Education Process Sector Stock Flow Diagram . . . . .	25
Figure 5.4	The Labor Sector Stock Flow Diagram . . . . .	27
Figure 5.5	The Education Quality Sector Stock Flow diagram . . . . .	29
Figure 5.6	The Research Sector Stock and Flow Diagram . . . . .	30
Figure 5.7	The Output Sector Stock and Flow Diagram . . . . .	31
Figure 5.8	The Budget Sector Stock and Flow Diagram . . . . .	33
Figure 5.9	The Jobs Sector Stock and Flow Diagram . . . . .	34
Figure 5.10	The Population Sector Stock and Flow Diagram . . . . .	35
Figure 5.11	Comparison of Simulation and Actual Data . . . . .	37
Figure 5.12	Base-Run Simulation Results . . . . .	40
Figure 5.13	Policy 1 (Increasing the grad_school_enrollment two fold) GDP Result. -1-: Base-run. -2-: Policy applied . . . . .	41

Figure 5.14 Policy 1 (Increasing the grad_school_enrollment two fold) Total Unemployment Result. -1-: Base-run. -2-: Policy applied . . . . .	42
Figure 5.15 Policy 2 (Increasing the new_academicians two fold) GDP Result. -1-: Base-run. -2-: Policy applied . . . . .	43
Figure 5.16 Policy 2 (Increasing the new_academicians two fold) Total Unemployment Result. -1-: Base-run. -2-: Policy applied . . . . .	44
Figure 5.17 Policy 3 (Increasing the university_enrollment two fold) GDP Result. -1-: Base-run. -2-: Policy applied . . . . .	45
Figure 5.18 Policy 3 (Increasing the university_enrollment two fold) Total Unemployment Result. -1-: Base-run. -2-: Policy applied . . . . .	46
Figure 5.19 Policy 4 (Increasing the acd_teach_factor from 0.6 to 0.8) GDP Result. -1-: Base-run. -2-: Policy applied . . . . .	47
Figure 5.20 Policy 4 (Increasing the acd_teach_factor from 0.6 to 0.8) Total Unemployment Result. -1-: Base-run. -2-: Policy applied . . . . .	48
Figure 5.21 Policy 5 (Increasing the Edu_inv_MoE_ratio five fold) GDP Result. -1-: Base-run. -2-: Policy applied . . . . .	49
Figure 5.22 Policy 5 (Increasing the Edu_inv_MoE_ratio five fold) Total Unemployment Result. -1-: Base-run. -2-: Policy applied . . . . .	50
Figure 5.23 Policy 6 (Increasing the Edu_inv_CoHE_ratio five fold) GDP Result. -1-: Base-run. -2-: Policy applied . . . . .	51
Figure 5.24 Policy 6 (Increasing the Edu_inv_CoHE_ratio five fold) Total Unemployment Result. -1-: Base-run. -2-: Policy applied . . . . .	52
Figure 5.25 Policy 7 (Increasing the Research_inv_ratio five fold) GDP Result. -1-: Base-run. -2-: Policy applied . . . . .	53
Figure 5.26 Policy 7 (Increasing the Research_inv_ratio five fold) Total Unemployment Result. -1-: Base-run. -2-: Policy applied . . . . .	54
Figure 5.27 Policy 8 (Increasing the teacher_grad_rate two fold) GDP Result. -1-: Base-run. -2-: Policy applied . . . . .	55
Figure 5.28 Policy 8 (Increasing the teacher_grad_rate two fold) Total Unemployment Result. -1-: Base-run. -2-: Policy applied . . . . .	55

Figure 5.29 Combined Policy 1 (Increasing the edu_inv_CoHE_ratio three fold, new_academicians two fold and grad_school_enrollment by 4000) GDP Result. -1-: Base-run. -2-: Policy applied . . . . .	56
Figure 5.30 Combined Policy 1 (Increasing the edu_inv_CoHE_ratio three fold, new_academicians two fold and grad_school_enrollment by 4000) Total Unemployment Result. -1-: Base-run. -2-: Policy applied . . . . .	57
Figure 5.31 Combined Policy 2 (Increasing the new_academicians, edu_inv_CoHE_ratio and res_inv_ratio two fold) GDP Result. -1-: Base-run. -2-: Policy applied . . . . .	58
Figure 5.32 Combined Policy 2 (Increasing the new_academicians, edu_inv_CoHE_ratio and res_inv_ratio two fold) Total Unemployment Result. -1-: Base-run. -2-: Policy applied . . . . .	58
Figure 5.33 Combined Policy 3 (Increasing the acad_teach_factor from 0.6 to 0.8 and increasing teacher_grad_rate and new_academicians two fold) GDP Result. -1-: Base-run. -2-: Policy applied . . . . .	59
Figure 5.34 Combined Policy 3 (Increasing the acad_teach_factor from 0.6 to 0.8 and increasing teacher_grad_rate and new_academicians two fold) Total Unemployment Result. -1-: Base-run. -2-: Policy applied . . . . .	60
Figure C.1 Sensitivity of Grad_school_enrollment. Range:[15000-25000] . . . . .	84
Figure C.2 Sensitivity of new_academicians. Range:[3000-5000] . . . . .	85
Figure C.3 Sensitivity of university_enrollment. Range:[375000-625000] . . . . .	86
Figure C.4 Sensitivity of acad_res_inv_ratio. Range:[0.332-0.552] . . . . .	87
Figure C.5 Sensitivity of acad_tea_factor. Range:[0.45-0.75] . . . . .	88
Figure C.6 Sensitivity of birth_rate. Range:[0.014-0.0234] . . . . .	89
Figure C.7 Sensitivity of Edu_inv_CoHE_ratio. Range:[0.0075-0.0125] . . . . .	90
Figure C.8 Sensitivity of Edu_inv_MoE_ratio. Range:[0.03-0.05] . . . . .	91
Figure C.9 Sensitivity of Grad_school_grad_job_ratio. Range:[0.0225-0.0375] . . . . .	92
Figure C.10 Sensitivity of Grad/uni. Range:[0.892- 1.49] . . . . .	93
Figure C.11 Sensitivity of High_school_enrollment_factor. Range:[0.637-1] . . . . .	94
Figure C.12 Sensitivity of Max output. Range:[131250-218750] . . . . .	95
Figure C.13 Sensitivity of Mortality. Range:[0.00443-0.00737] . . . . .	96

Figure C.14 Sensitivity of Mortal_0_to_5. Range:[0.0165-0.0275]	97
Figure C.15 Sensitivity of Quit_or_dismissal_rate. Range:[0.0015-0.0025]	98
Figure C.16 Sensitivity of researcher_worker_ratio. Range:[0.00187-0.00313]	99
Figure C.17 Sensitivity of Reseach_inv_ratio. Range:[0.00547-0.00912]	100
Figure C.18 Sensitivity of Uni_grad_job_ratio. Range:[0.09-0.15]	101
Figure C.19 Sensitivity of Uni_\non_uni. Range:[1.5-2.5]	102
Figure D.1 Extreme Conditions Test Results for grad_school_enrollment. Min = 0	103
Figure D.2 Extreme Conditions Test Results for grad_school_enrollment. Min = 400000	104
Figure D.3 Extreme Conditions Test Results for new_academicians. Min = 0	105
Figure D.4 Extreme Conditions Test Results for new_academicians. Max = 20000	105
Figure D.5 Extreme Conditions Test Results for university_enrollment. Min = 0	106
Figure D.6 Extreme Conditions Test Results for university_enrollment. Max=1000000	106
Figure D.7 Extreme Conditions Test Results for acd_tea_factor. Min = 0	107
Figure D.8 Extreme Conditions Test Results for acd_tea_factor. Max = 1	107
Figure D.9 Extreme Conditions Test Results for birth_rate. Min = 0	108
Figure D.10 Extreme Conditions Test Results for birth_rate. Max = 1	108
Figure D.11 Extreme Conditions Test Results for high_school_enrollment_factor. Min = 0	109
Figure D.12 Extreme Conditions Test Results for high_school_enrollment_factor. Max = 1	109
Figure D.13 Extreme Conditions Test Results for mortality. Min = 0	110
Figure D.14 Extreme Conditions Test Results for mortality. Max = 1	110
Figure D.15 Extreme Conditions Test Results for mortal_0_to_5. Min = 0	111
Figure D.16 Extreme Conditions Test Results for mortal_0_to_5. Max=1	111
Figure E.1 Sensitivity run for the weight of norm_other_sector_inv_\all_workers. Range: [0.3-0.5]	112
Figure E.2 Sensitivity run for the weight of tech_indicator. Range: [0.3-0.5]	113
Figure E.3 Sensitivity run for the weight of std_edu_quality_factor. Range: [0.3-0.5]	113

## LIST OF ABBREVIATIONS

1. acd	: academic
2. CIA	: Central Intelligence Agency
3. CoHE	: Council of Higher Education (YÖK)
4. edu	: education
5. Eğitim-sen	: Education and Science Laborers Union (Eğitim ve Bilim Emekçileri Sendikası)
6. EIB	: European Investment Bank
7. EIS	: European Innovation Scoreboard
8. EU	: European Union
9. GDP	: Gross Domestic Product
10. grad	: graduate
11. HDI	: Human Development Index
12. inv	: investment
13. max	: maximum
14. MoE	: Ministry of Education (MEB)
15. mortal	: mortality
16. norm	: normalized
17. OECD	: Organization for Economic Co-operation and Development
18. pop	: population
19. R&D	: Research & Development
20. res	: research
21. std	: standardized
22. tea	: teaching
23. tech	: technology
24. TPE	: Turkish Patent Institute (Türk Patent Enstitüsü)
25. TÜBİTAK	: The Scientific and Technological Research Council of Turkey (Türkiye Bilimsel Araştırma Kurumu)
26. TÜİK	: Turkish Statistical Institute (Türkiye İstatistik Kurumu)
27. UN	: United Nations
28. unemp	: unemployed
29. uni	: university
30. WIPO	: World Intellectual Property Organization



# CHAPTER 1

## INTRODUCTION

Humanity has experienced several stages of development and demonstrated an evolution along centuries. With the industrial revolution, new inventions lead to mechanization, which substituted manpower to some extent. From then on, almost all of the innovation leaps had the aim of reducing production, transportation, shipping or communication costs. Getting closer to the present time, the rate of change of progress in technological developments has increased, as can be seen in Figure 1.1.

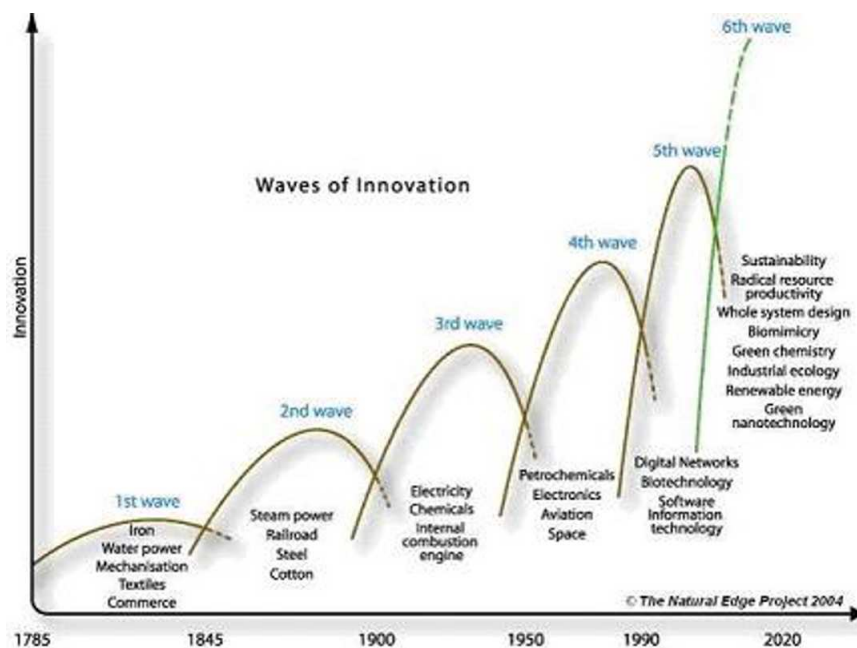

Figure 1.1: Waves of Innovation [12].

It is very hard to manage this rapid "change" and sustain a stable prosperity for a society.

Sustainable development, which is not a new topic of discussion, finds a quite formal and clear definition in the most frequently quoted declaration of the Brundtland Commission as: "meeting the needs of the present without compromising the ability of future generations to meet their own needs" [61]. This notion merges seeking solutions for both the natural and social problems of the world without negatively affecting the quality of lives of the upcoming generations.

The sustainable development of a society can be assessed in three dimensions: environmental sustainability, economic sustainability, and sociopolitical sustainability. Figure 1.2 illustrates the confluence of the dimensions of sustainable development.

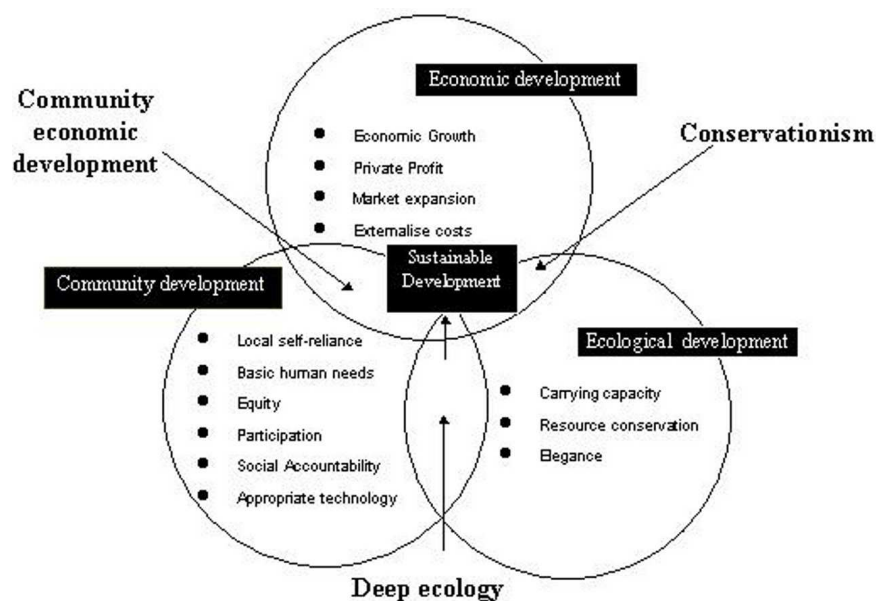

Figure 1.2: Three Dimensions of Sustainable Development [30].

The economy of a society is its fundamental aspect and economic sustainability, which is referred to as "strong sustainability" [27], is an essential part of social sustainability. The new wave, which considers knowledge and human capital as the key factors of industry, is named as "the new economy" by the economics circles. It is stated that "the new economics reflect the growing worldwide demand for a new direction of economic development and progress, which will be *people-centered* and *Earth-centered*" [71].

Although environmental sustainability is at the center of attraction for many researchers recently, we believe that the road to sustainability passes through the behavior of individual

and collective population units. A possible enforcement of socioeconomic limitations is also conceivable just like natural limitations. Therefore, sustainability planning is inevitable for socioeconomic systems in order to understand the limiting factors in the long run. As it is well known, it is harder to measure and monitor social systems. No flawless work is possible that can represent all the complexities and interrelationships within a real system. Generating indicators can help us represent critical bits of information and can turn into a prevention tool by making us aware of previously unseen developments and their predicted impacts. By summing up the current state, possible futures and alternative policies for real problems, it can also be an effective way of explaining ideas and values shaped in the context of these problems. Thus, it can help decision makers gain insight in the actual issues.

The "human" factor, which is evidently the essential element of this new era, is the *sine qua non* feature of the industrial engineering discipline as well. What makes industrial engineering distinct from other engineering fields is recognized as the systemic perspective that is directed to studies, gathering the information from mathematics, natural and social sciences, with analytical principles and techniques of engineering. Güven marks to the point in such a way that, industrial engineers have to question, understand and direct *social practice* by means of technological tools, and to carry out systematic inquiry [49]. Therefore, it looks for solutions and policies for not only manufacturing but also for various real life systems. Since qualified human resource is the most valuable capital of the era, studies on planning and decision making about it are mandatory.

Policy making about human resources on a macro level must be associated to some basic factors such as education, population, employment, research (technology), economic growth and investment. The interdependence and interaction among these factors constitute a complex dynamical system. We think that this system is one of the crucial subsystems of a nation for its sustainable development.

First off, *the knowledge society* requires qualified human capital, states Yamaç. What is meant by qualified human capital here is being well-educated, with high intellectual capacity and inclined to innovation. But the author warns that the economic contribution of the implied well-educated should be examined. For the expected positive contribution of the knowledge based economy, the determination of requirements of right experts in the right fields is a critical necessity [86]. Since technology has come to a certain post-industrial level, the strength

of brain muscles rather than of triceps became more desirable.

The aim of this study is to analyze the structure and dynamics of education, employment and economic development in Turkey, by using the most basic variables and parameters, and to identify the most critical ones, i.e., to the changes of which the system is most sensitive. Employees will be classified according to their education levels. Both qualitative and quantitative measures of education will be generated. How they affect the system will be observed. Also, the effect of technology on worker efficiency will be embedded into the system.

In order to perform a policy analysis, the System Dynamics methodology is proposed for this circumstance. It is one of the most operative instruments for modeling social systems which are somewhat data lacking. It is found to be a suitable tool for quantifying the system components and their relations. Since optimization is not always achievable, especially for socially influenced systems, simulating the system structure will be advantageous for constructing a model close to the real system. The technical details of the methodology will be discussed in Chapter 2.

In Chapter 3, the System Dynamics models developed to analyze similar systems are surveyed. The survey looks into the models that investigate the dynamics of corporate level, university level or country level interactions. All these systems intend to observe different outcomes.

In Chapter 4, the connection between education, research, labor and economic growth is described. The problematic state of Turkey within this context, and related imposed policies are explained.

Chapter 5 conceptualizes the system to be analyzed. The system boundaries and subsystems are defined. The dynamic hypothesis is formed and the relationships are explained as model equations. The model is operationalized for the Turkish education and economic system. Experimentation of the model for analyzing different policies is performed.

The results are discussed in Chapter 6, and the improvable ways are addressed.

## CHAPTER 2

### METHODOLOGY: SYSTEM DYNAMICS

#### 2.1 Evolution and Principles

”System” is an enigmatic notion that has no single definition. There are various systems surrounding us that have different complexities. Under the basis of scientific thought and effort, lies the wish to understand the structure and behavior of all kinds of systems. Origins of systems thinking can be seen in the arguments of Descartes in the 17th century [29]

” to divide each of the difficulties that I was examining into as many parts as might be possible and necessary in order best to solve it [and] beginning with the simplest objects and the easiest to know ... to climb gradually ... as far as the knowledge of the most complex”

System dynamics approach has primitively evolved against Newton’s mechanical philosophy that is based on the predictability and linearity of mechanical phenomena. Along with the enhancement of quantum and chaos theories, things turned out that positive mechanical science is not the only scientific way of thought. It is understood that systems generally are neither deterministic nor linear.

Although *systems approach* has its roots in several other disciplines such as philosophy, sociology, biology or physical sciences, it has fundamentally been a special field of study with Bertalanffy’s work on ”general system theory” [20].

As a methodology, system dynamics is developed by J. W. Forrester and his friends from the Massachusetts Institute of Technology during the late 1950s and early 1960s. The concepts behind system dynamics are closely related to cybernetics, organization theory, control theory and mathematical modeling. Forrester is seen as ”one of the first to react to the perceived

failings of OR, and other management science techniques” [50].

Forrester started the studies in this field under the name of “industrial dynamics” [33]. In [33], it is stated that a dynamical system can be designed in order to understand the behavior of the real system and computer simulation might be used for analytical investigation of the influences of policies and delays.

Gates et al. (1970) highlights the subjectivity of the system dynamics models such that the determination of the qualitative parameters is up to the modeler [46].

Forrester (1971), in parallel, states that social systems are harder to comprehend and they are complex systems of high-order with multiple loops and nonlinear feedback structures. By means of system dynamics, social systems can be observed like realistic laboratory models. System dynamics models are not time-series driven directly, but they include recent assumptions for the policies and structure. The system dynamics approach is different from common practice since it does not solely rely on information or data. Other approaches try to predict the output from a black box by only looking at the input and state that analyses can be perfected with more data. System dynamics puts a higher emphasis on the internals and the interactions of the box. Social systems have three misleading characteristics: (1) presenting unexpected behavior away from where symptoms occur, (2) having a small number of unexpectedly sensitive (high-influence) points, (3) contradictory reactions at different points in the time horizon (short or long run). [35]

Schroeder (1972) also makes the inference that system dynamics is a convenient modeling technique rather than other techniques:

”Based on the hypothesis that the human mind is too limited to keep track of large numbers of interrelated variables, models are being built which call upon computers to perform this task. ... The whole system dynamics methodology, developed for the purpose of modeling and improving social systems, is predicated upon the thesis that empirical data is not the foremost requirement for building useful models. .. Whereas many models are built with the intent of solving a particular problem, the objective in system dynamics is to show **how the problem was created.**”

Furthermore, Schroeder emphasizes that people, who are in interaction or familiar with the system considered, is the source of data. Another point that Schroeder denotes is that social systems are fairly insensitive to parameter changes. He states that the criticisms, which

concentrate on very small discrepancies in system dynamics models, miss the point. [73]

Forrester has several other studies describing the characteristics and extensions of system dynamics [34] [44] [41] [37] [42] [38] [40] [39]. Other important contributors of the system dynamics methodology are Nielsen [79], Peterson [67], Graham [47], Checkland [25], Senge [74], Barlas [17] [15] [13] [14], Daellenbach [26] and Jackson [50] [51].

As a consequence, system dynamics has turned into a desirable modeling technique and a decision support mechanism for analyzing complicated affairs and policy making in various sectors. System Dynamics practices in the literature are categorized into three groups with respect to their scopes [64]: (1) Systems of industrial dynamics, (2) Systems at sectoral levels, (3) National and global systems. Currently, researchers and professionals working in this field congregate under a platform named "The System Dynamics Society" which is an international and not-for-profit organization [65].

## **2.2 Structure of System Dynamics Modeling**

### **2.2.1 Feedback Loops**

A feedback is defined to be *"the process through which a signal travels through a chain of causal relations to reffect itself"* [48]. This circular interaction reaches significance as time passes by. Therefore, the mysterious complexity behind dynamical systems originate from feedback loops within the systems. There are two types of feedback loops which are: Positive (Reinforcing) Feedback and Negative (Balancing) Feedback. Positive feedback loops are disposed to be generating exponential growth, whereas negative feedback loops fight back with change.

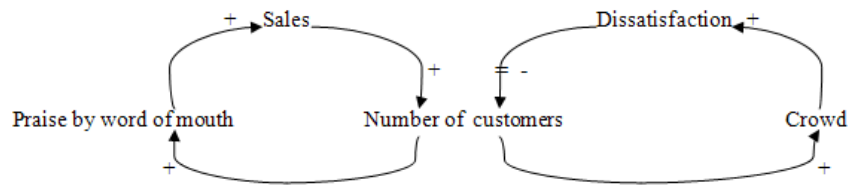

Figure 2.1: Illustrative Growth Model for a New Established Restaurant

### 2.2.2 Building Blocks

**Stocks (Levels):** The stocks are the reservoirs where the entities in the system accumulate. They represent the state of the entity at any time  $t$ . They can store either tangible or intangible assets. "Every feedback loop must contain at least one stock accumulation that stores the changes generated around the loop" [60]. The software gives you "the circular connection error" otherwise.

**Flows (Rates):** These are the "rate of change" of stocks over time. In other words, they are the taps that fill and empty the stocks. The clouds represent any stocks that are outside the model boundary, and hence the modeler is not interested.

**Converters (Auxiliaries):** They convert inputs to outputs by holding a constant value, defining external input, doing algebraic operations or drawing graphical functions.

**Connectors:** They are the arrows that transfer the information from one block to another so that the block from which the arrow starts is used in calculating the value of the block that the arrow arrives.

**Ghosts:** Duplicates, which are the dashed copies of stocks or converters, are used for only simplifying the view.



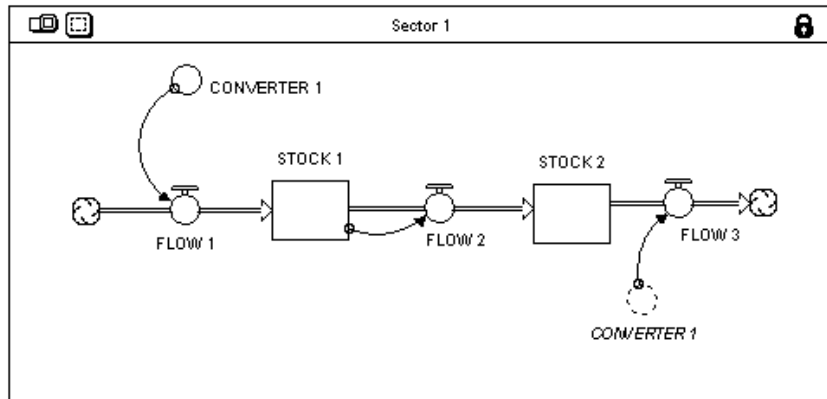

Figure 2.2: Basic Building Blocks of System Dynamics Modeling

### 2.2.3 Mathematical Relations

When the building blocks are completed, the mathematical relations can be defined. The value of each block holds a function whose inputs are defined by the connectors. Although systems dynamics models represent continuous event systems, it is not easy to solve corresponding differential equations analytically. Therefore they are replaced with difference equations in order to be solved numerically. As a result, the relations turn into simultaneous set of difference equations. The most generalized form of model equations can be represented as:

Given Stock (0),

$$Stock(t) = Stock(t - dt) + (inflows - outflows) * dt, \quad (2.1)$$

### 2.2.4 Stages of System Dynamics Modeling

Modeling is the process of understanding the real system and looking for better ways of representing it in the simulation. Since every system is unique, there are no sharp laws of modeling in general. However, an outline of modeling phases is agreed on:

1. Developing a system relations map
2. Defining the variable types and constructing the building blocks

3. Collecting data
4. Developing a simulation model
5. Simulating steady state / stability conditions and reproducing reference mode behavior
6. Validating the model
7. Sensitivity and policy analysis [88].

The process is recurrent and any former step can be returned back whenever necessary.

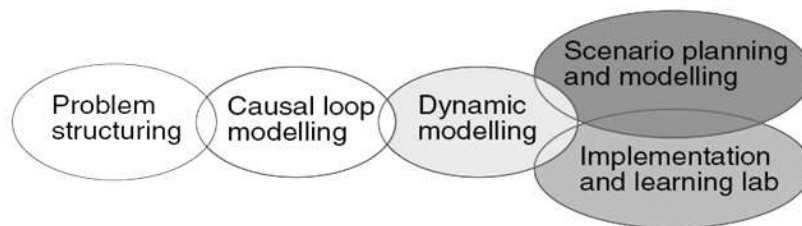

Figure 2.3: Phases of Systems Thinking and Modeling Methodology [88].

## CHAPTER 3

### LITERATURE SURVEY

System Dynamics models of many types have been developed for inspecting or planning education, research, technology, manpower and the quality or funding of the related institutions or systems. The models reviewed in this survey are limited to those that are related to the dynamics of quality and quantity, or to those that deal with country level systems in size. The order of the studies is chronological.

Özgül's M.Sc. thesis [64] provides a dynamical simulation model that is produced with the aim of policy analysis and decision making at the Middle East Technical University - Industrial Engineering Department. The main subsystems of the system are determined to be faculty, student, facilities and personnel, and budget and prestige. The interactions between these variables are hypothesized and converted into model equations. For obtaining the intangible parameters, Worth Assessment and Delphi methods are used. The evaluated policies are related to the time allocation of faculty, strengthening the doctorate program and training faculty within the department, student admission capacity, scholarship, assistant support, and salary levels. The key findings of the model are that a higher education system has a long response time and the dominating loops of the model are around the faculty sector.

Galbraith [45] has a model that represents the mechanism of school, university and labor force sectors of Australia and aims to clarify the issues about the future of higher education system and related social problems in the context. The author argues that labor force, productivity, population, and education participation rates are not independent matters, but they all influence each other. The key variable of the system is designated to be the "professional labor force / total labor force". When the supply of qualified labor force exceeds demand, some of the excess graduates are assumed to be accepting jobs that they are overqualified for, and they

are regarded as an "underemployed labor force" in the study. The model is started with 1976 conditions since the latest fully available data belongs to that time. The model is put through several parameter changes. The main characteristic of the model output is the oscillatory response of enrolment and unemployment levels. Additionally, one of the most fundamental indicators for the future of the system is the everlasting growth of mature age undergraduate enrollment. Some of the generated scenarios created extreme fluctuations which imply too much difficulty in management under the associated conditions.

Barlas and Diker have two sequential works [18][19] concerning a dynamic simulation model for strategic university management. The interactive simulation game ("UNIGAME") is built on the potential university problems that are long-term and complex and that should be dealt by the ones in prominently higher positions. The internals of quality and overheads of instruction, research, and projects (sponsored/unsponsored or income generating) are investigated. Boğaziçi University's data (1983-1997) is used in model calibration. The outcome of the model is transformed into an interactive game by using Vensim software. Results address that the platform in question has a systemic structure such that no single decision individually can achieve its purpose without being in coherence with other related adjustments.

Kennedy and Clare [54] argue that statistical linear models or spreadsheets which are often used in managerial decision making are not sufficient for higher education environment. System dynamics has a great potential for planning in this field. Kennedy [53] provides a detailed survey of the system dynamics models of higher education. He constructs a matrix of system dynamics models which has dimensions of "Hierarchical Level" and "Specific Area of Concern". Most of the studies in this classification are not specifically to our interest due to scope or scale. The ones that are found to be more relevant and their findings are described in our survey.

In Durgun's study [31], a system dynamics model is constructed in order to analyze technology improvement policies for Turkey. System dynamics methodology is found appropriate for the study since the issue has plenty of interactions with social, economical and technical notions and institutions. The influence diagram of the system is constructed and some cluster zones emerge. For the development of the model, 11 sectors have been used which are: *Outward-Inward Investment, R&D Expenditures, Economy GNP, Economy Ratios, Population, Universities, TUBITAK Projects, Education Level, Technology Value Added, Industrial*

*Development and Technology Improvement.* The stocks, flows and converters in the simulation model are aggregated into the largest possible sector. "i-Think" software is chosen for model building and the simulation runtime is set to be between 2000 and 2014. The data used in the simulation model follow the real figures as much as possible. Five scenarios were produced including the base run. The current trends for some parameters are altered in the experimentation. Eventually, the model reveals that the number of risk capital firms, high-to-low technology export ratio, number of firms cooperating with University-Industry Research Centers (USAMs), number of USAMs, article per instructor ratio, education level, both private and government R&D expenditures, technology effect on GNP and inward investment should be increased and the ratio of the inward-to-outward investment should not be fluctuated or decreased in order to reach the technology improvement goals.

Rodrigues and Martis [72] develop a system dynamics model of engineering education based on a competence pool of engineers according to knowledge management and human resource management principles. The aim of the system is to match the desired level of the competence pool to the actual level of the competence pool. A stepwise control policy is applied on the policy parameters. They are varied in order to find the optimum arrangement. In conclusion, the authors claim that the competence gap can be minimized by better tuning the duration of engineering training programs.

Reflections of Lee's Ph.D thesis (2003) which is on the dynamics of integrated circuit industry of Taiwan can be seen in the article [56]. Making use of questionnaire and interview results in the simulation model, the study aims to give an insight into the dynamics of capital flows, human resource flows, knowledge and technology flows, and product flows in the national innovation system. The model has five main sectors: financial, human resources, science and technology transfer, innovation commercialization, and market. The authors indicate the necessity for judgment in determining some of the system parameters. Policy tests are made about time, science and technology, and R&D budget. Three consequences of the model are: (1) the length of the adjustment time and delay directly affect the rate of innovation and time to adjust to the desired goal respectively, (2) raising institute "spin-out", government grants or industry R&D budgets alone will not be enough to improve the innovation performance, (3) multiplying the R&D budget or R&D capacity alone is not a warranty for increasing the innovation performance by the same proportion.

Oyo et al. [63] suggest that the basic funding system for higher education can be simplified into three sections that are the *Funding Mechanism*, *Institutional Strategies* and *Institutional Outcomes*. Each section is divided into five sub-factors. Also, they state that the underlying relations among these factors cannot be handled with linear methods. The scope of higher education management's problems is categorized into three: quantitative issues, qualitative concerns and mixed type. A preliminary survey is conducted in two public and two private Ugandan universities and a model is generated including the following 5 sectors: *funding and strategic planning*, *students*, *research and publications*, *teaching and academic staff*. The simulation runtime is set to be between 2000 and 2012 within the STELLA software. The policy experimentations are performed with the aim of *achieving optimal academic staff numbers*, *enhancing students' outcomes* and *seeking improvements in allocation of available funds*. Two conclusions are drawn from the simulation results. Initially, gains other than tuition should be directed to staff and research firstly, rather than increasing the rate of student enrollment. Secondly, more funding allocated to research from tuitions is rational and government, donor institutions and bilateral organizations should be stimulated for further sourcing of research. On the whole, using system dynamics for analyzing interactions between funding and quality issues is demonstrated to be proper. The authors claim that the findings in the study are anticipated to be generalisable to any country.

The model developed by Park et al. [66] is a system dynamics model that aims to forecast manpower demand and supply for the sustainable growth of the information security (IS) industry in Korea. Being different from the literature, the authors progressed from *corporate level forecasting* to *industry level forecasting* with this study. The authors come up with a *flexible saturation point* for the market growth of the sector based on the reality of interdependence of one sector with other related sectors. The IS Manpower in the system is classified into five qualification grades according to the standards of the Korean Ministry of Science and Technology. The time period for the simulation model is set to be between 2003 and 2015. Three policy alternatives are suggested: *more government investment on encouraging college graduates to enroll graduate programs*, *to reinforce existing manpower conversion programs to canalize workers in related industries to IS industry* and *to divide the current one-year vocational training programs into a one-year and a two-year program*. It is seen that the existing imbalance between demand and supply can be reduced by the policy alternatives.

Spearow's thesis [76] introduces a system dynamics model with the aim of indentifying the

optimum labor force mix in the U.S Naval Air Warfare Center Weapons Division under the changing workload conditions. The institution employs both civilian and contractor workers who are subject to different contracts and that makes the system harder to analyze. The simulation is run for 10 years and the results demonstrate that the most critical variables in the system are the leaving rate of civilians, rate of successful hires and acceptance of work. The developed tool, which intends to predict the system behavior, serves hiring workers with the right qualifications and making this process cost efficiently.

Quigley [69] looks into the economic benefit of higher education in UK using system dynamics modeling. Government policy for achieving 50% participation is found to be increasing the costs to enroll to universities. This policy is examined in terms of *degree obtaining costs* and *potential monetary returns* considering the demographic factors. The primary parameters are expected to be the *degree demand/supply*, *expected salary according to degree*, *years employed with/without degree* and *total cost of degree*. A causal loop diagram of the economic benefits model is provided but technical details of the model are not fully available since the study is an ongoing process.

The models surveyed above show that system dynamics offers advantage and potential to be used in analyzing the dynamics of the subject of concern. Although the methodology is widely used for policy analysis in the literature, it is well nigh impossible to find system dynamics models for policy making in Turkey other than Durgun [31].

## CHAPTER 4

# INDICATORS OF EDUCATION-DEVELOPMENT RELATIONSHIPS

### 4.1 Returns on Education

In Limits to Growth [59], one of the outcomes of the model is that services such as education and health facilities should be favored rather than manufacturing material goods being the economic activities of the society for sustainable development. Globalization has brought the world to a point where variability is at high levels. This variability is seen in the very rapid changes and responds to changing environmental and market conditions. In other words, world affairs are hypersensitive to global conditions. On the other hand, a consistency is observed between the income and knowledge levels of knowledge-creating countries. Therefore, industrialization solely is not enough for competence. Generating the knowledge content is fundamentally important.

In this context, it can be said that education has a high added value in the development of the society. Therefore, we believe that education should lie in the center of the act of envisaging. Education has multi-sided benefits for the society. An extensive research of OECD-EIB indicates that nine net outputs of education can be considered: rising income, better individual/public health, lower birth rate, democratization, political stability, reduction of poverty and inequality, increasing environmental consciousness, reduction in crime rate, reduction in social and property offenses as cited by [84].

The "Human Capital Theory" has set forth the advancement that education has generated in economic growth and quality of labor. Although the research around the frame of this theory is not limited to education, it generally involves empirical education measures and generates



outcomes that affect education staff and educational decision making [78]. Especially for developing countries, investment in human capital is anticipated to be enhancing the development of a country.

According to Korkmaz, the relationship between education and economy can be summarized as follows: development of the manpower that economy requires, cost of conducting and utilization of educational services, educational expenditure, creating income effect of education on macro and micro levels, educational demand and supply, association of education with productivity, education service as a "good", and education-finance relation[55].

There are plenty of studies and examples about the profitability of educational investments [84] [52] [83]. Blaug says that "Educational planning by the state with the purpose of promoting economic objectives is now as universally approved as economic planning itself" [21]. The rate of return on educational investment is known to be much higher than physical investments such as in the housing sector [58]. The main reason behind this reality is that education increases the efficiency of the potential labor force and gives rise to new products and technologies leading to new production methods.

Rivera-Batiz argues that 1 point increase in the average education of a country enlarges the economy roughly by 0.7%. Half of this 0.7% development is distinguished as the direct contribution of education, and the other half comes true by the bilateral interaction between education and economy (positive feedback mechanism) [70]. Studies conducted in Turkey indicate that rising the education level by increasing the compulsory education duration from 5 years to 8 years had a positive contribution to the economic growth [80].

Especially higher education has a considerable contribution since it is in close association with the economy. Özgül states that the two main roles of higher education are: producing manpower to be utilized as specialists in several sectors of the national economy and accumulating scientific knowledge and experience by research [64]. An essential prerequisite to a country's technological progress is awareness of necessity of a good higher educational system.

## 4.2 Over-Education Theory

Another perspective to be taken into account is the "over-education theory"[81][75]. The viewpoint claims that a mismatch between educational qualifications and job requirements has a negative effect on the economy. Educational investment made on an individual does not return as the expected efficiency in such a case in the long run. In addition to this, an individual, who is uncomfortable with a job that has less requirements than he has and the earning distributions, loses motivation and hence efficiency.

## 4.3 Turkey's Status

Supporting education and innovation is known to be the road to sustainable development. But the position of Turkey around this subject is problematic.

- Educational expenditure per capita is 950 dollars in Japan, 817 dollars in Germany, 523 dollars in Italy, whereas it is about 90 dollars in Turkey [23].
- The OECD countries' (except United States) education investment per student is 9130 dollars on the average and this value is 6 times more than that value of Turkey [23].
- The educational expenditure per GDP is 3.8 % in Turkey, whereas it is 6.1 % on the OECD average [82].
- The average education level of the adult population (25-64 years) is 9.6 years in Turkey, whereas it is 11.9 years on the OECD average. Turkey holds the third lowest order [32].
- The comparative "Research and Development expenditure per capita" among OECD countries can be seen in Figure 4.1. The "Research and Development expenditure per capita" has increased from 43 dollars to 98 dollars from 2003 to 2008 [5] .
- According to the EIS data, the innovation performance of Turkey is much less than the EU average. Especially in human resources productivity, the performance of Turkey is one of the lowest. [10]

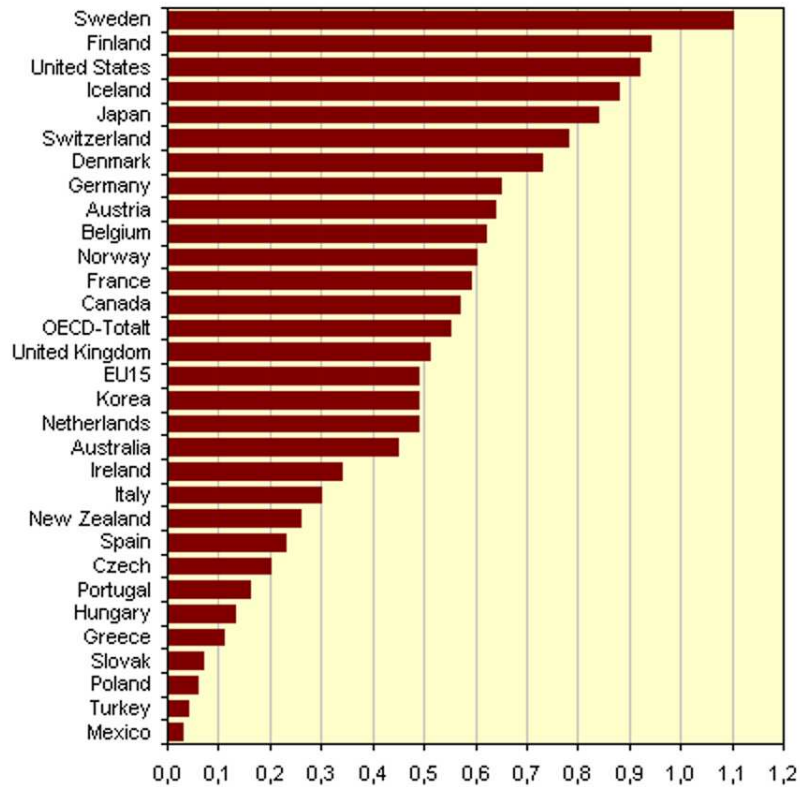

Figure 4.1: Research and Development Expenditure per Capita (Thousands of US dollars. Source: OECD. Data up to and including 2003)

#### 4.4 A Brief Summary of Science and Technology Policies in Turkey

After the importance of science and technology in the development of the country is realized, the Turkish Republic has switched into the "planned development model" in 1960s. The process which starts with the 1st Five Year Development Plan (1963-1967) has continued until present with the 9th Five Year Development Plan (2007-2013) [87]. The science and technology studies became more of an issue with "Turkish Science Policy 1983-2003" and "Turkish Science and Technology Policy 1993-2003" documents. However, it cannot be said that they were put into practice in terms of their goals. "Not sharing a common vision of political power, public, private sector and universities" is assigned as the reason to this issue. This observation has lead to the preparation of the project "Vision 2023: Science and Technology Strategies" [11].

Recently, establishing new universities with the aim of "at least one university for every district" is in the agenda of public and Turkish National Assembly. Like every country, Turkey

seeks economic growth, by producing distinctive goods in terms of knowledge content. However, this is a long and complex process.

## CHAPTER 5

### MODEL FORMULATION AND ANALYSIS

”Endogenous growth” models, taking the name from the so called theory, are based on the idea that in a closed system, policies can affect the growth of the economy in the long run. Our model in this sense can be considered as an endogenous growth model. There are various views on the mutual effects of education and research on the economic development. However, the manner of this effect is not fully understood. Analyses made on this subject generally are based on direct projections of the related factors. But, there are too many tangible or intangible factors that determine these relations, which are not independent nor interdependent in essence. This interlinked system might require simulation for coming to decisions. This model might provide a conceptual simplistic point of origin for detailed studies. For analyzing this type of system, the System Dynamics methodology is seen to be fit. The main steps of the system dynamics model are pursued in this chapter.

#### 5.1 Problem Conceptualization

##### 5.1.1 System Boundaries

Every model has a boundary since it is not possible to represent every bit of reality inside of it. Our model is limited to the interrelations among stakeholders of education and research, and their influence on the economic development. The motives why Turkey is examined in this study, rather than a more generalized model are:

- The author’s familiarity with the investigated system.
- The availability or convenience of reaching experts who can deliver opinions.

- Simplicity of reaching more precise data.
- Turkey's being in need of new policies: the unfavorable position where Turkey stands among other countries in the world in this context.
- The necessity of looking into the interiors of a particular system in order to generate policy since every system has its own characteristics and dynamics.

Barlas states that the model boundary should be sufficiently broad so that the model frame is adequately diverse to represent the intrinsic description, and sufficiently narrow so that the variables are controllable for policy analysis by purification of the variables that are out of the focus. In other words, the model can represent the "selected aspects" of a true system concerning "specific problem(s)" [16]. On this account, although modeling a system in the scale of a country sounds tremendous, we have selected the only variables that are found significant in this content. Any extreme conditions such as natural disasters or wars are left out of the boundary. All the model variables can be seen in Appendix A.

In fact, for precisely anchoring just a single variable in this list, an immensely extensive and long term work would probably be required. However, the point is different in our case. We aim to catch any system reaction in time that is associated with the interrelations in the system. For the perceptibility of the model, a great deal of aggregation is necessary. In addition to that, certain assumptions are utilized since it is impossible to quantify every single detail in the model.

### **5.1.2 The Causal Loop-Influence Diagram**

Our system is composed of some subsystems that we termed sectors. These sectors and their interactions are conceptualized in Figure 5.1.

These subsystems may be further divided into sub-factors. The interrelations among the system variables are the main driving force and they enable to reveal where the bottlenecks or weak points in the system lie. There are several causal relations between model elements. The causal relations are stated under the condition that all other factors are equal. The causal loop diagram is seen as the "dynamic hypothesis" that expresses the problem of concern [16]. The causal loop diagram for our system is constructed as in Figure 5.2.

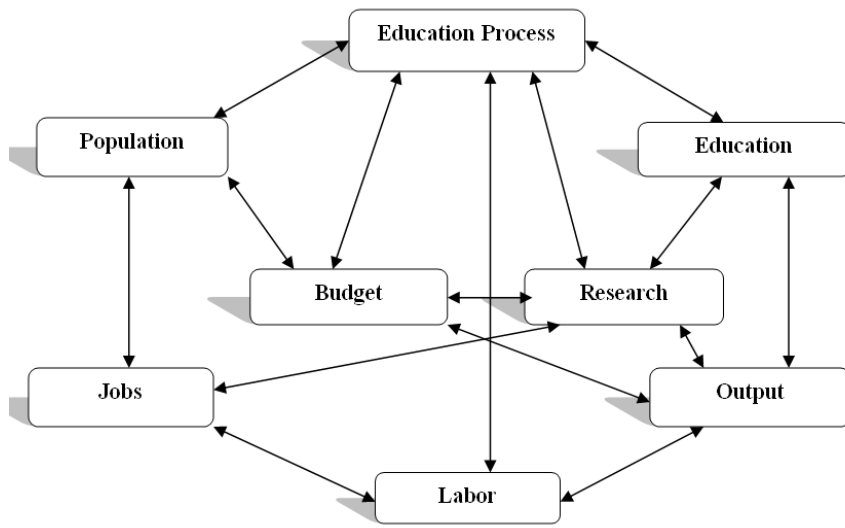

Figure 5.1: Model Sectors and Their Interactions

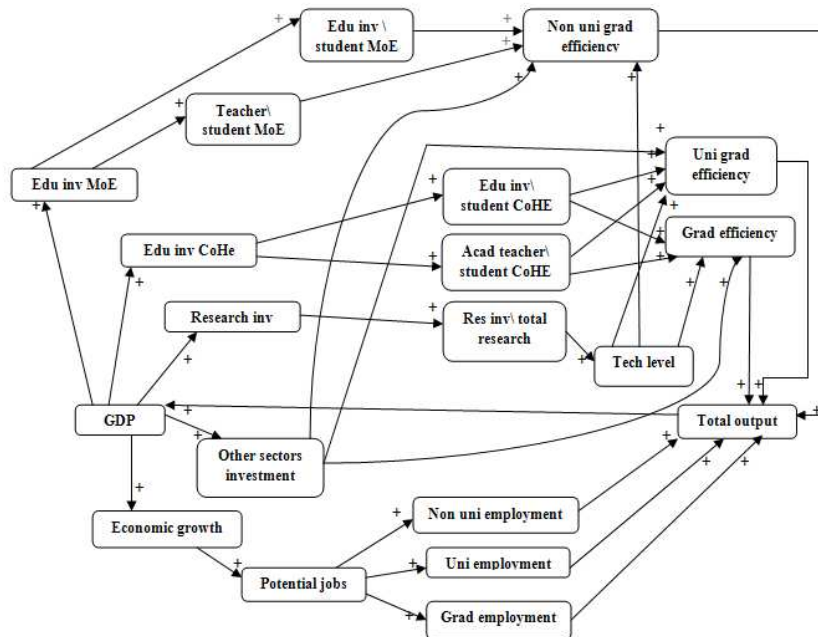

Figure 5.2: The Causal Loop Diagram of the Model

## 5.2 The Model

There are three entities flowing in the system which are human beings, money and jobs. They appear in different interrelated sectors.

### 5.2.1 The Education Process Sector

This sector includes the process of a human entity from its birth (entering the system) to the last academic level that it reaches. The stocks represent the level of schools (consistent with Turkish Education System), which are Primary School, High School, University and Graduate School, from lower to higher. Students are accepted to stay in the Primary School Stock for 8 years, in the High School for 4 years, in the University for 4 years and in the Graduate School for 5 years in the average. Preschool children stock holds the children aged from 0 and 5 until they start school. All children are assumed to take primary school education since it is required by the law in Turkey. Students who graduate from a level are assumed to be either passing to the next school level or leaving education and flowing into the unemployment stock of the entities from the same education level. High School enrollment is determined by a factor that represents the ratio of the students continuing education to all students in that generation. On the other hand, University and Graduate School enrollments are assumed to have quota every year. After finishing the graduate school, some of the individuals become academicians again by an average quota representing the position roster determined by the CoHE each year. Since academicians have two simultaneous missions as teaching and research, a factor is utilized for finding the full-time equivalent number of academic teachers and academic researchers. The initial case of the factor is determined as the percentage of time that an academician spends for education and research.

$$acd\_res\_factor = 1 - acd\_tea\_factor \quad (5.1)$$

All academicians are assumed to be working for 25 years on the average and leave the job by joining the retired academician stock. The stock flow diagram of this sector can be seen in Figure 5.3.



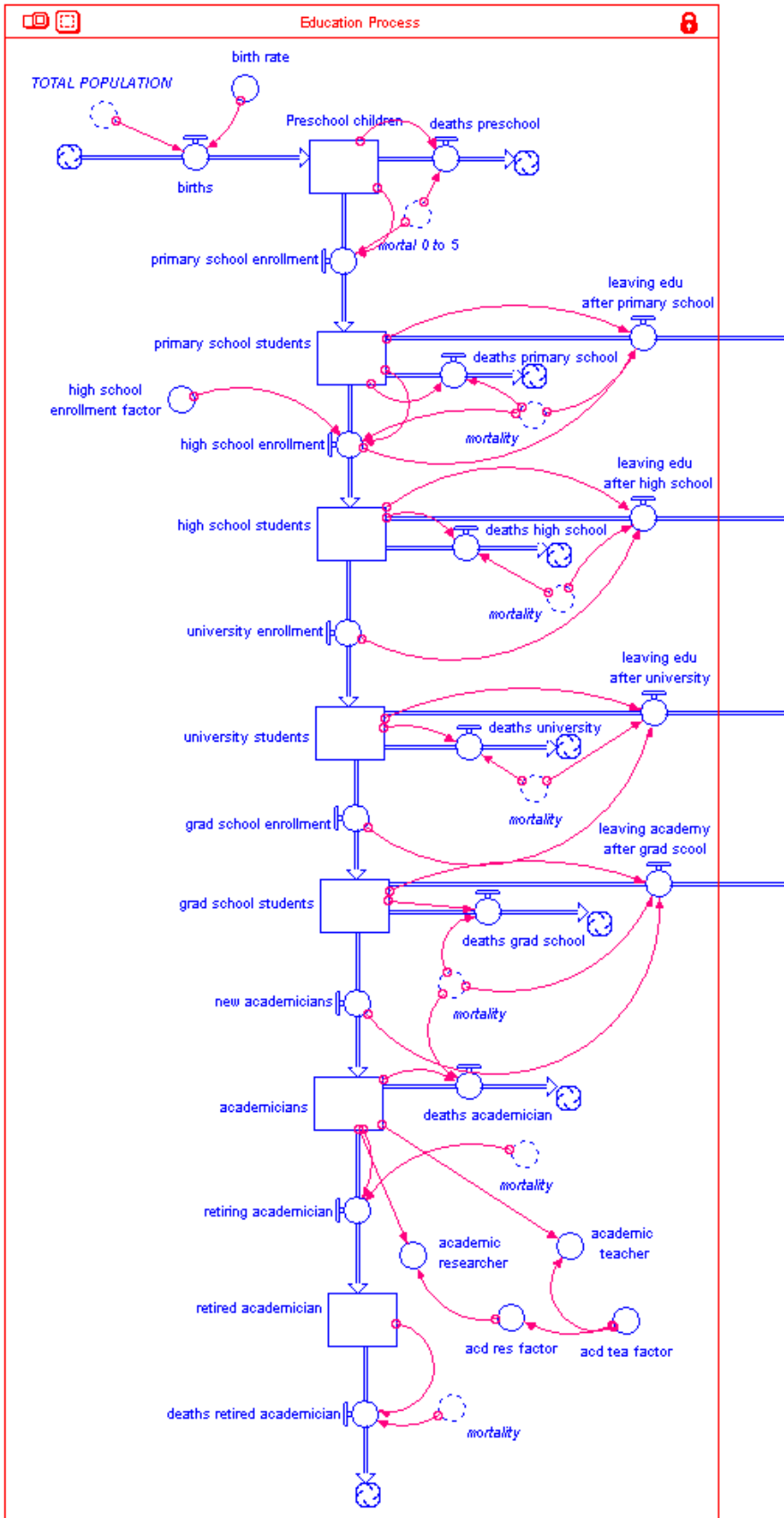

Figure 5.3: The Education Process Sector Stock Flow Diagram

### 5.2.2 The Labor Sector

This sector includes the workers classified according to their academic backgrounds. All the labor force in the country except teachers and academicians are aggregated. Since the basic aim of our study is to see the affect of the education sector, academicians and teachers will be analyzed separately. The criticality of the quantity and type of education and research personnel in examining the social development is also mentioned in [86].

After leaving education, entities arrive in the labor sector by entering the unemployment stocks first. Primary School and High School graduates are aggregated as "non-university graduates". Therefore there are three unemployed individuals stocks and three working individuals stocks for non university graduates, university graduates and graduate school graduates. This categorization relies on the view that the contribution of the workers from each category to the economy is different. It is assumed that free positions to be filled that year are distributed among the levels of education with certain proportions so that:

$$non\_uni\_grad\_job\_ratio + uni\_grad\_job\_ratio + grad\_school\_grad\_job\_ratio = 1 \quad (5.2)$$

A constant annual quit\_or\_dismissal rate is applied for all categories. In the retiring mechanism, it is assumed that all workers work for 25 years on the average and leave the job by joining the retired stocks.

Teachers are also university graduates, but they are separated from the rest of the university graduate workers. The number of new teachers entering the teachers stock annually is determined by the teacher graduation rate i.e., proportion of number of teacher graduates to all university graduates that year. And at the same time, the teacher graduation rate is also expressed as a graphical function of:

$$\frac{educational\_investment\_MoE}{INIT(educational\_investment\_MoE)} \quad (5.3)$$

so that within certain limits, it is assumed that when the educational investment for primary and high schools increases, that increases the availability and attractiveness of university education in education departments, i.e. more teachers graduate every year. The stock flow

diagram of this sector can be seen in Figure 5.4.

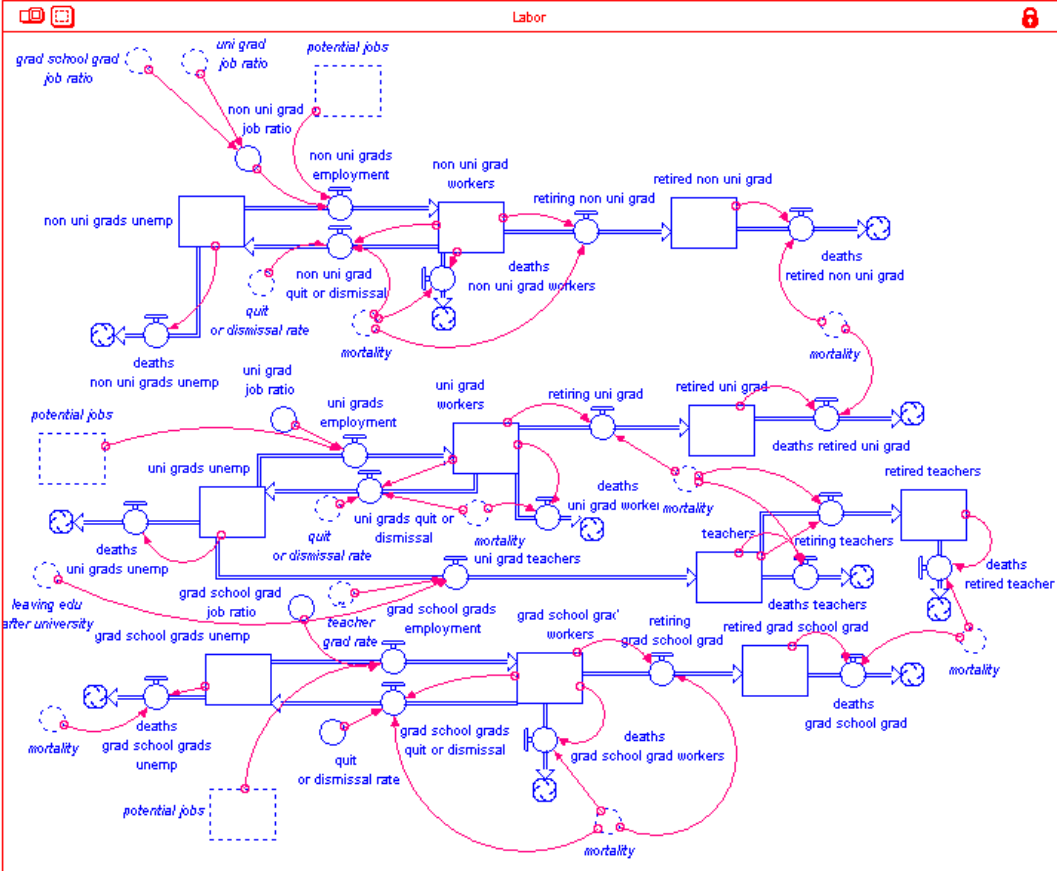

Figure 5.4: The Labor Sector Stock Flow Diagram

**5.2.3 The Education Quality Sector**

In this sector, two education quality factors are constructed which are for MoE and CoHE education levels. MoE students are the total of Primary School and High School students. CoHE students are the total of University students and Graduate School students. The education quality factors are defined to be dependent on the educational investment per student and teacher per student values. Graphical functions are constructed for the education quality factors to sketch the relationship between education quality factor and the input values which are:

$$edu\_inv\_per\_student\_MoE * teacher\_per\_student\_MoE \quad (5.4)$$

and

$$edu\_inv\_per\_student\_CoHE * acd\_teacher\_per\_student\_CoHE. \quad (5.5)$$

The quality factors are defined so as to vary between 0 and 1 linearly. Whereas the input values are allowed to take values that are nonnegative. Their maximum values are taken to be the corresponding value of Norway. The reason why Norway is chosen is that it is one of the countries that have the highest Education Index <sup>1</sup> and Human Development Index <sup>2</sup> at the same time [28].

The generated quality factors are standardized according to the corresponding labor category. This standardization is required because education quality factors will be used in finding the efficiency multipliers of the labor categories. Therefore entities with higher levels of education should have higher quality factors of education. In order to do the standardization, two converters (grad/uni and uni/non\_uni) are defined. These converters help to express the quality factors in terms of each other. Williams says that quantifying the labor quality is generally done by assessment of educational standards. Although accurate measures of education quality are hard to compute, one of the measures of education quality can be "the total number of years of schooling" [85]. We used this approach in designating the two converters: grad/uni and uni/non\_uni. The stock flow diagram of this sector can be seen in Figure 5.5.

---

<sup>1</sup> "Education Index: The educational component of the HDI, which is comprised of adult literacy rates and the combined gross enrolment ratio for primary, secondary and tertiary schooling, weighted to give adult literacy more significance in the statistic."

<sup>2</sup> The Human Development Index (HDI): "The first Human Development Report (1990) introduced a new way of measuring development by combining indicators of life expectancy, educational attainment and income into a composite human development index, the HDI". <http://hdr.undp.org/en/statistics/indices/hdi/>

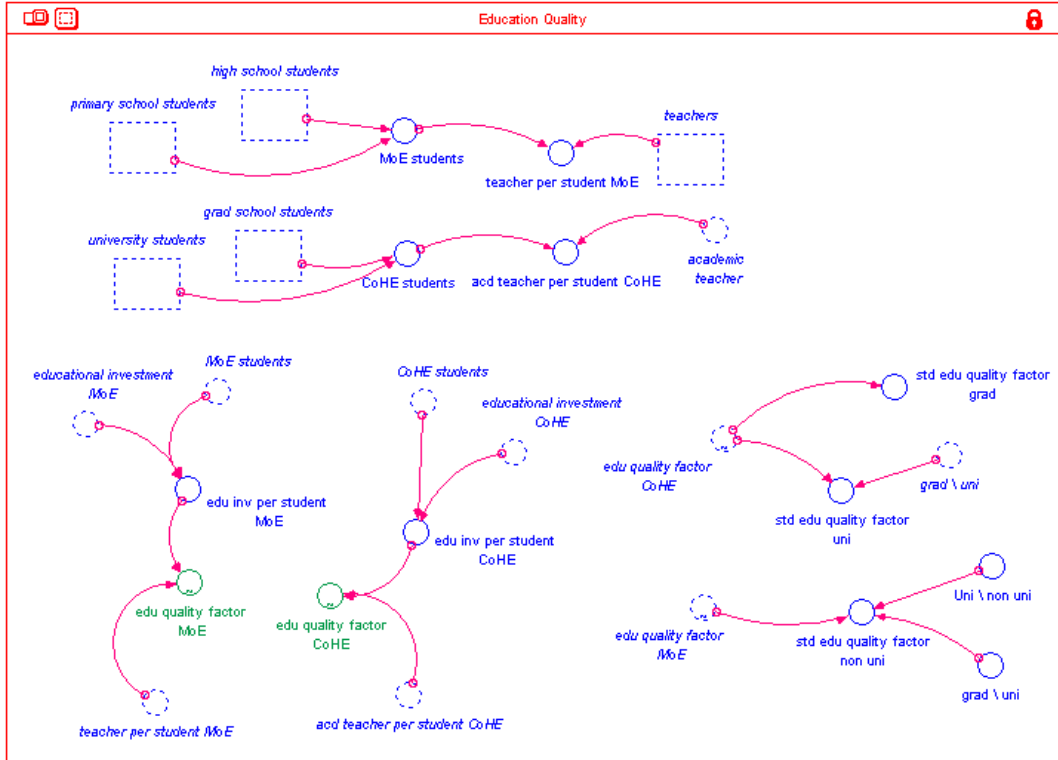

Figure 5.5: The Education Quality Sector Stock Flow diagram

## 5.2.4 The Research Sector

The researchers in the sector are handled in two groups: academic researchers and all the other researchers that are working in the sectors out of university. The research standard is assumed to be determined by the total research investment per researcher. This ratio is mapped into "granted patents per thousand population" indicator since the most common parameter used in determining technological innovation level is the "patent data" [24]. In this case, the maximum of the "patent per thousand population" value is determined according to the United States value, that is one of the highest patents per population values in the world [62]. This patent indicator value is normalized as follows:

$$Norm\_patent\_per\_1000\_population = \frac{patent\_per\_1000\_population}{\max(patent\_per\_1000\_population)} \quad (5.6)$$

The obtained normalized value is seen as a technology level indicator of the country. Since

higher technology also contributes to productivity, the indicator will be used in determination of the efficiency coefficients as a component. The stock flow diagram of this sector can be seen in Figure 5.6.

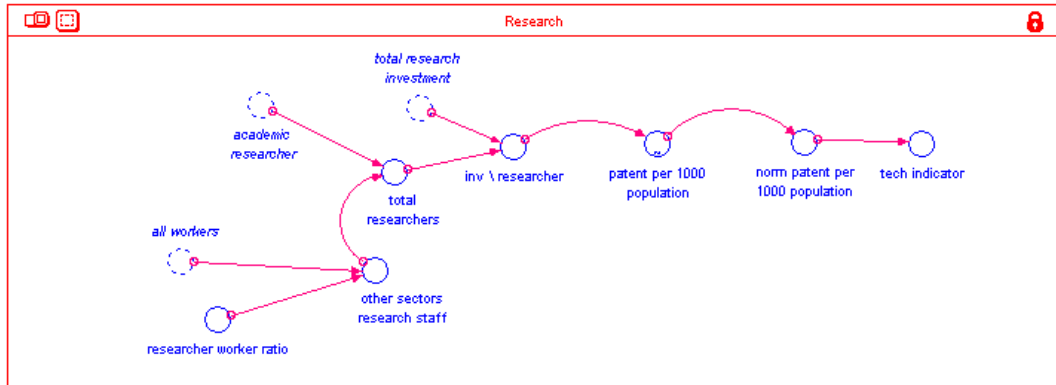

Figure 5.6: The Research Sector Stock and Flow Diagram

### 5.2.5 The Output Sector

In this sector, the outputs of the labor categories are specified. Three factors are defined to be identifying the efficiency ratio of a worker which are: technology indicator, standardized education quality factor and normalized other sector investment per worker. The efficiency ratio will determine the unit output of a worker being multiplied by a maximum output value. Lastly, the total outputs of each labor category amount to the total output that makes up the GDP. The stock flow diagram of this sector can be seen in Figure 5.7.

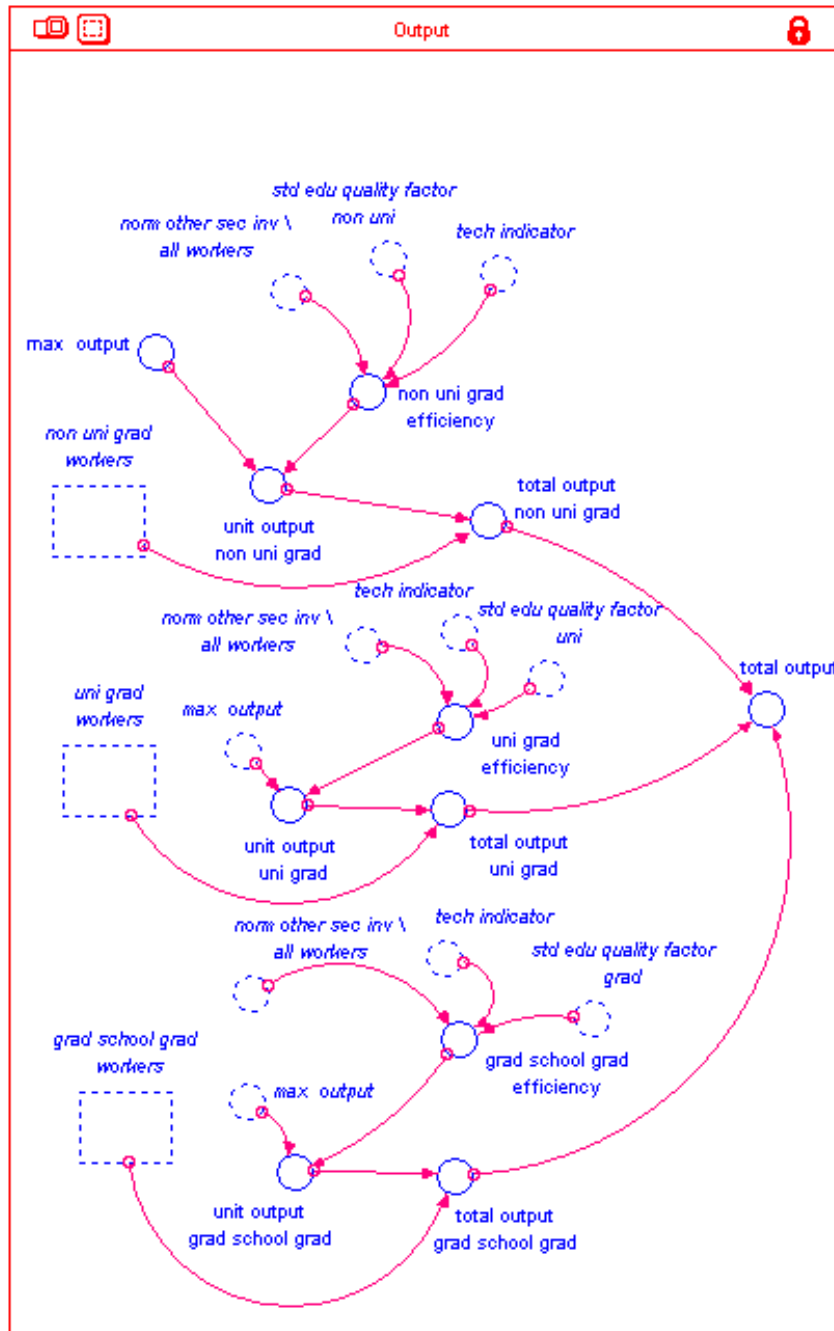

Figure 5.7: The Output Sector Stock and Flow Diagram

### 5.2.6 The Budget Sector

This sector represents the income and expense board of the country. The total annual output is directly reflected as the total GDP. The spending is distributed as educational expenses (MoE and CoHE), research expenses (academic research and other research) and other sectors expenses. The percentages of education and research investments in the GDP are particularly set as investment ratios. The rest of the GDP expenses are aggregated under the name of other sectors investment.

$$\text{other\_sectors\_investment\_ratio} = 1 - (\text{edu\_inv\_CoHE\_ratio} + \text{edu\_inv\_MoE\_ratio} + \text{research\_inv\_ratio}) \quad (5.7)$$

The annual GDP growth is denoted by "economic growth" and is formulated as:

$$\text{IF}(\text{TIME} = 0) \text{ THEN } 1 \text{ ELSE } \frac{\text{GDP}}{\text{HISTORY}(\text{GDP}, \text{TIME} - 1)} \quad (5.8)$$

The stock flow diagram of this sector can be seen in Figure 5.8.



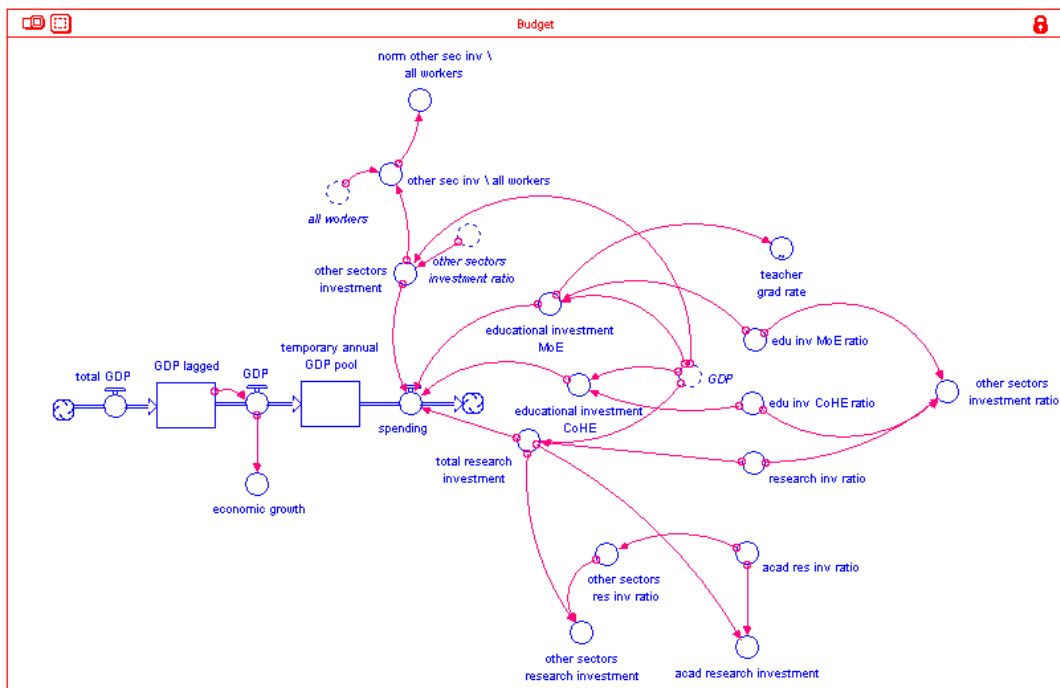

Figure 5.8: The Budget Sector Stock and Flow Diagram

### 5.2.7 The Jobs Sector

The annual employment is assumed to be changing with respect to economic growth. The jobs that are vacated by quits/dismissals, retirements or deaths constitute the new jobs when multiplied by the economic growth factor. All the new jobs are assumed to be filled by the new recruits. The stock flow diagram of this sector can be seen in Figure 5.9.

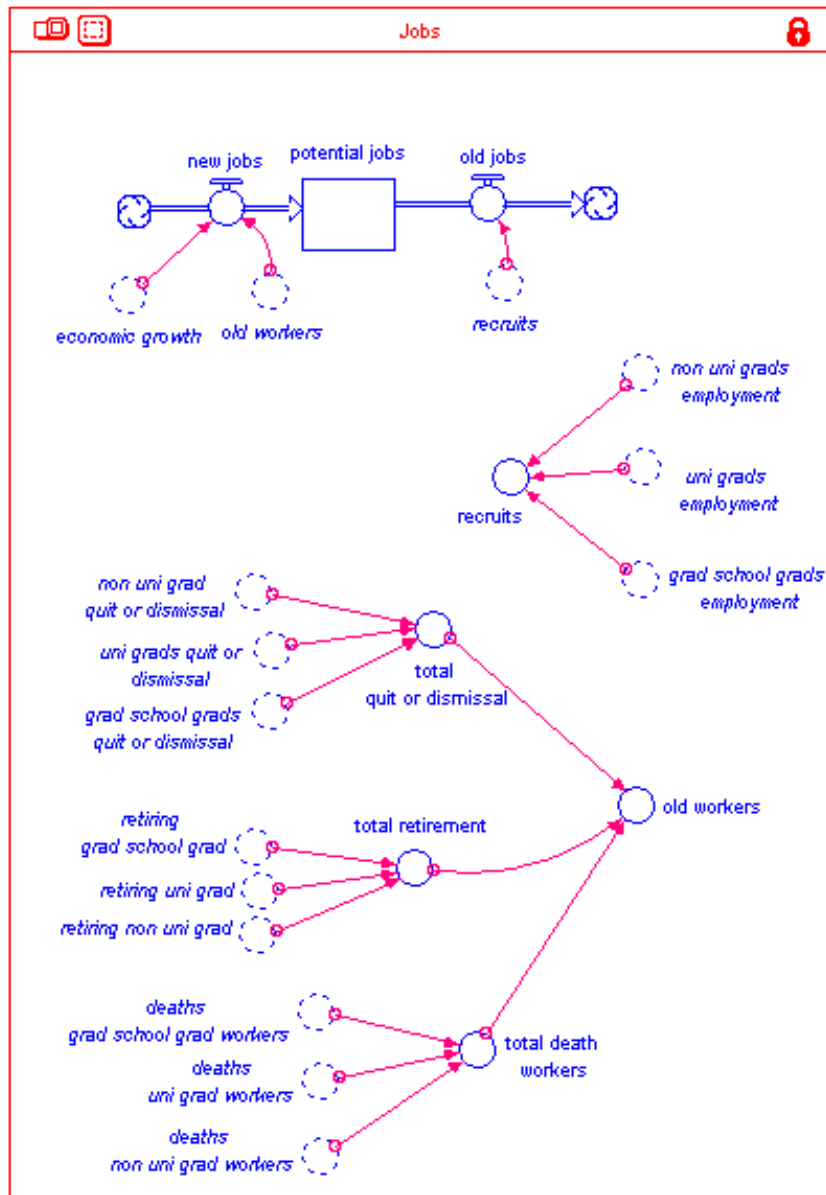

Figure 5.9: The Jobs Sector Stock and Flow Diagram

## 5.2.8 The Population Sector

All the population units are collected in order to find the total population in this sector. Total population is lagged for one step in order to avoid circular connections. The stock flow diagram of this sector can be seen in Figure 5.10.

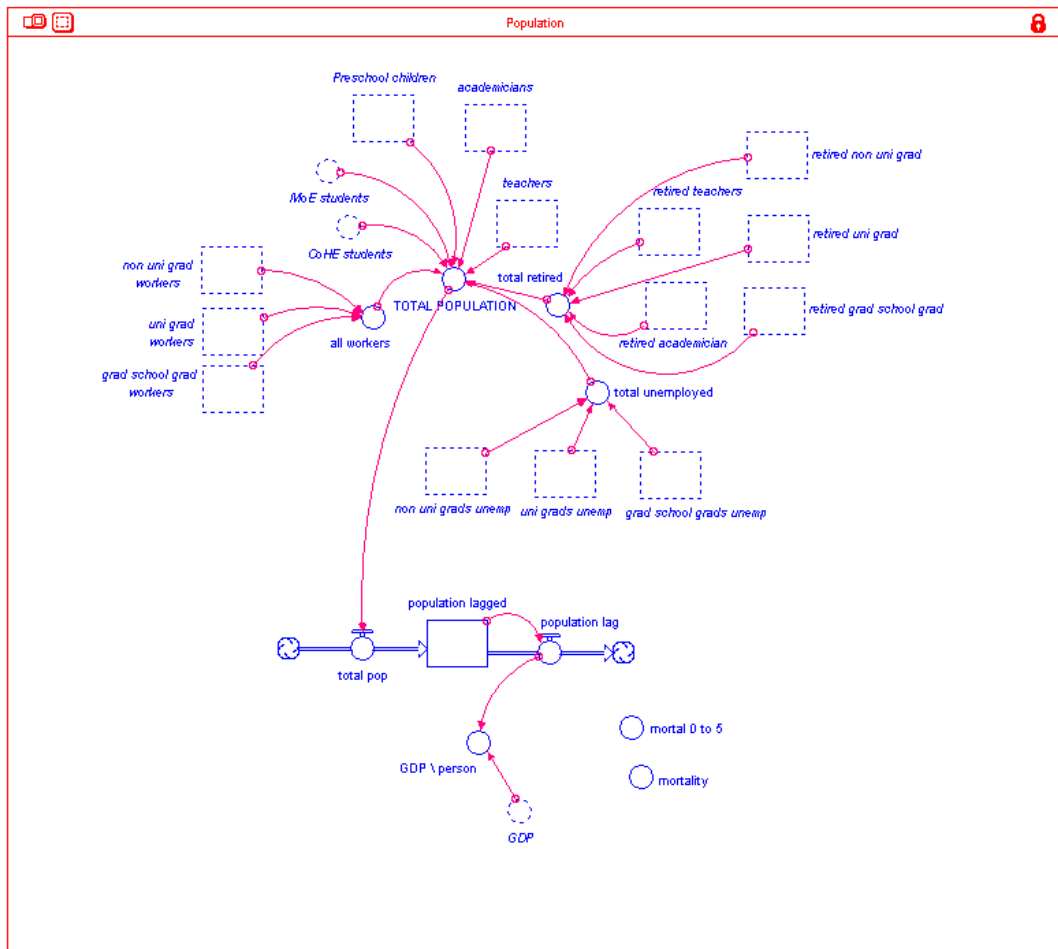

Figure 5.10: The Population Sector Stock and Flow Diagram

All model equations are provided in Appendix B.

## 5.3 Model Execution

System Dynamics models are considered to be continuous event simulation models. The Euler method will be used as the numerical integration algorithm for solving the simultaneous set

of equations of the model. The time unit is chosen to be years since all the data that we have are recorded annually. For consistency, the step size (dt) is taken to be 1/12 meaning that a year is divided into 12 months. The monetary unit is dollars and the unit consistency check is done. The length of the simulation is taken to be 8 years. This is because the aim of the model is not predicting the long-term future of the country (as in fortune telling), but to find out how the education and research problem can be intervened. Since any instantaneous trend in the indicators might affect the policies, too long simulation runtimes will be meaningless. The model components are deterministic and can be changed on purpose of alternative scenario making. Simulation is started in 2008 and correspondence of simulation time and real time are given in Table 5.1.

Table 5.1: Simulation Time vs. Real Time

Simulation time	0	1	2	3	4	5	6	7	8
Real time	2008	2009	2010	2011	2012	2013	2014	2015	2016

## 5.4 Data

The necessary data were tried to be collected as much as possible. Since the simulation starts in year 2008, the initial values were regulated accordingly. When the 2008 figures were not available, the latest available figure has been used. The data sources that are utilized are: UN Data [8], TÜİK [6], TÜBİTAK Statistics [5], CIA The World Fact Book [1], The World Bank Data [4], Eğitim-sen Bilgi-Belge [2], TPE[7], WIPO Patent [9] and Statistics Norway [3]. When some necessary data are not found precisely, expert opinions or common view are applied.

## 5.5 Verification and Validation

Forrester says that no objective proof of validity of a model exists [36]. Therefore in general, the term model utility is preferred to model validity. Mass and Senge [57] mention that if the following three conditions are satisfied, the confidence of the model increases:

- All the model elements and defined interrelations have a described real world meaning,

i.e. there exists a correspondence between the represented structure and real system.

- When the historical periods are simulated, variables demonstrate more or less the qualitative and quantitative behavior that is observed in the real system.
- When the extreme conditions are tested in the simulation, the obtained modes are reasonable.

The simulation output and real data for population and GDP of 2008 and 2009 can be seen comparatively in Figures 5.11(a) and 5.11(b). The resemblance of the two is found satisfactory in terms of behavioral tendency and the difference between model value and real values in 2009 are not far out from each other.

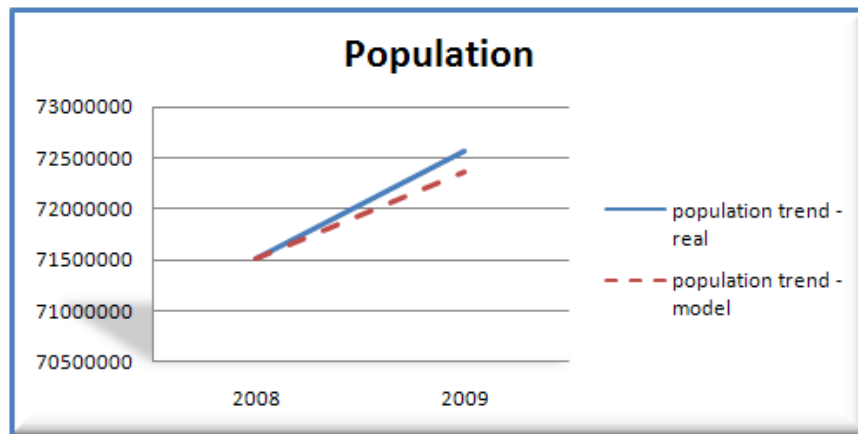

(a) Population

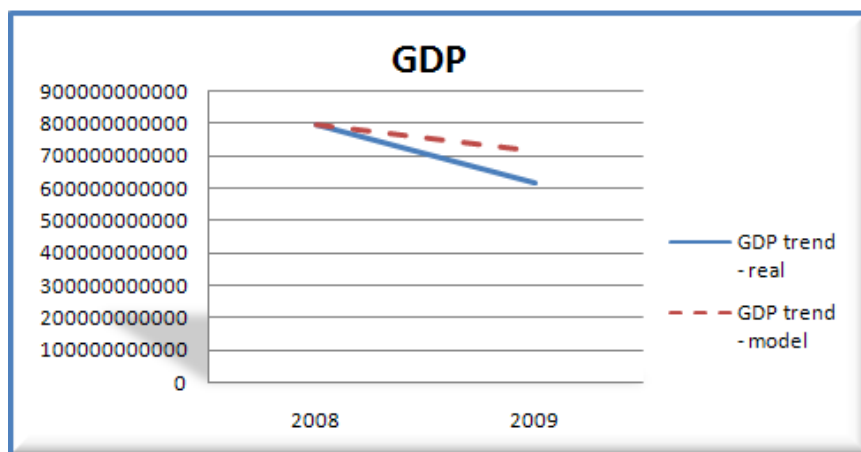

(b) GDP

Figure 5.11: Comparison of Simulation and Actual Data

Sensitivity analysis has been performed with the aim of revealing any possible error in the parameters. It is seen that the model behavior is not sensitive to most of the model parameters when the range is set to be reasonable, which means anomalies are not met. In other words, the system is stable and no sudden leaps, oscillations or asymptotic behaviors are observed. It displays the same qualitative behavior either slower or faster. Sensitivity analysis experimentation results can be seen in Appendix C. Extreme conditions test is also applied for selected reasonable variables. The results can be seen in Appendix D. Forrester and Senge [43] state that extreme conditions test can be done by utilizing presumed minimum and maximum values. By applying this test, policies that might affect the system to behave in a different way than its past behavior can be analyzed.

## **5.6 The Model Utility**

With the 22 stocks, 47 flows and 70 converters, our model is a reduction of the real system. Definitely, the information on the inputs and causal relations are incomplete and imperfect. But although the model may be considered as a rough sketch, it is of use in many senses;

- By defining the causal relations and hence constructing the dynamical hypothesis, we address the data that are required to be improved.
- Despite not having absolutely exact data, the model is propitious to re-execute and analyze. The simulation start-time can also be altered and the initial values can be changed accordingly, since the system dynamics models are sensitive to the initial conditions.
- There are no dynamical analyses that look through the education-economy relations and evaluate policies. The decisions are given according to statistical projections or to mental models in general. Our model gathers data from several sources and intuitions into its causal loop structure.
- The model is an initiative which is open to criticism that will make contribution to better understanding the system and hence better evaluating the alternative policies.

## 5.7 Policy Formulation and Experimentation

### 5.7.1 Base-Run (No policy alternative)

The model is simulated when all the variables are kept in their current values. The following results are obtained; in Figure 5.12. In the base-run results, it is seen that if no action is taken the GDP decreases, and the total population and unemployment increases. GDP per capita follows the GDP, but since we applied constant birth and death rates, GDP per capita decreases comparatively faster. In the figure, each of the variables is plotted on a different scale. The base-run assumes no fundamental changes in the system or no outer effects that lead to major changes in the system. Although the decrease in the GDP can be associated with the global economical crisis, we do not claim to make exact predictions by considering all types of possible discontinuous events. The main argument is to gain insight and perception by observing the system behavior. Therefore the policy evaluations are more important than base-run results.

In our model, the most significant factor is the efficiency of the workers in the formation of the total output (i.e. the GDP). And the efficiency multiplier is assumed to be determined by equally weighing the `norm_other_sec_inv\_all_workers`, `tech_indicator`, and `std_edu_quality_factor`, the first two of which are the same for all workers with different academic backgrounds. However the calibration of these efficiency factors constitutes a primary trade-off in the model. The assignment of relative weights given to `norm_other_sec_inv\_all_workers`, `tech_indicator`, and `std_edu_quality_factor` will certainly influence the standard-run case results. For analyzing this effect, three more converters are defined for the relative weights of these three parameters. Sensitivity analysis is conducted for the new factors. (Results can be seen in Appendix E) It is observed that higher weight for `norm_other_sec_inv\_all_workers` means higher GDP, whereas higher weight for `tech_indicator` and `std_edu_quality_factor` means lower GDP. On the other hand, `std_edu_quality_factor` is more sensitive to increase than `tech_indicator`. This symptom can be interpreted as follows: If the sectoral investment per worker is more important in determining the efficiency of the workers than the other two factors, then with the current policies the GDP of Turkey is getting better. If the technology level is dominating, then the GDP is getting worse. And finally, if the education quality is decisive, then GDP is in its worst case among the others. This observation designates the necessity for precise

investigation of the determinants of the worker efficiency factors. Nevertheless, without loss of target, we take the factors counterweight.

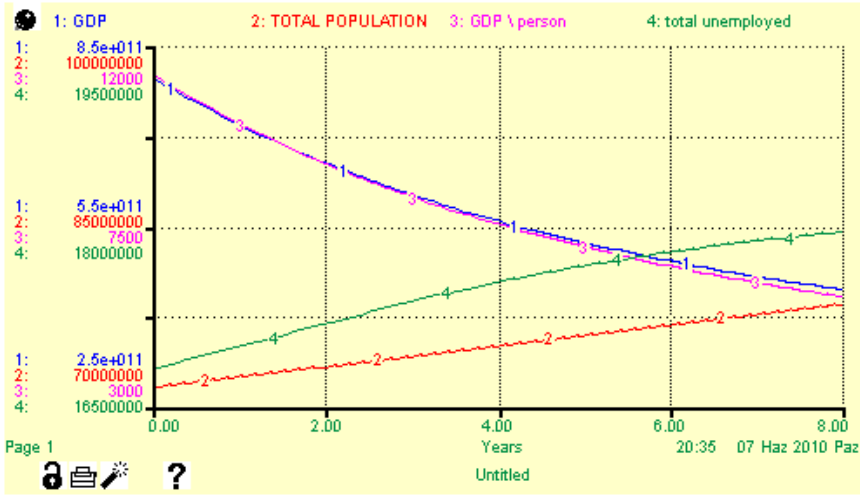

Figure 5.12: Base-Run Simulation Results

### 5.7.2 Alternative Scenarios

Policy analysis deals with the behavior of the model against different policy parameters or policy structures [16]. Patton and Sawicki indicate that alternative policies can be determined fundamentally by utilizing methods such as no-action analysis, literature survey, analogy, metaphor, synectics, brainstorming, comparison of real world experiences, etc.[22] . Taking these methods into account, we have formed alternative policies regarding the number of educational staff, student enrollment, educational investment and research investment, which are our main variables of concern. The following analysis demonstrates the scenario outcomes such that the specified policy is put into practice when the simulation time equals 0. Notice that the blue curves (–1–) indicate the base-run result, and the red curves (–2–) indicate the result after the policy is applied. The indicators are chosen to be GDP and total\_unemployment.

#### 5.7.2.1 Single Policy Alternatives

1. **Increasing the grad\_school\_enrollment two fold:** This policy alone is not effective because, increasing only the number of students in the graduate school will decrease



the quality of higher education, by reducing the number of academic teachers per student. Although the grad\_school graduates are assumed to have higher efficiency, the education quality factor compensates it, therefore no considerable effect is observed in the GDP. The result can be seen in Figure 5.13.

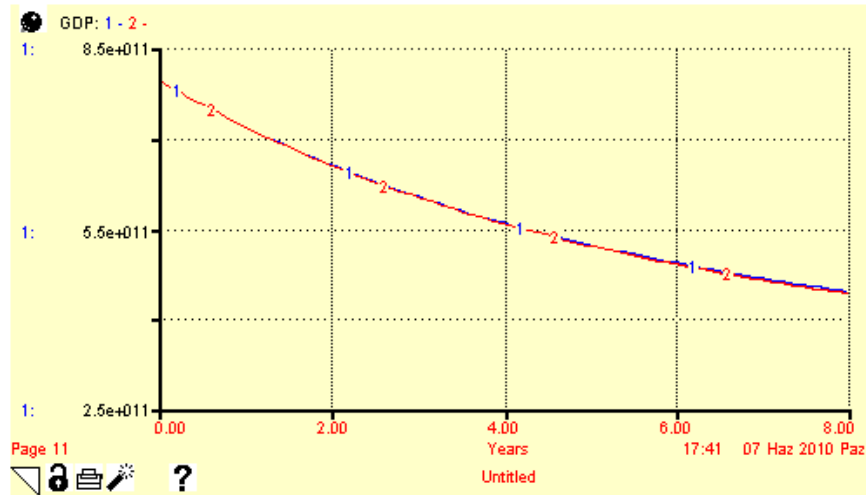

Figure 5.13: Policy 1 (Increasing the grad\_school\_enrollment two fold) GDP Result. -1-: Base-run. -2-: Policy applied

On the other hand, the total unemployment starts to decrease. The result can be seen in Figure 5.14.

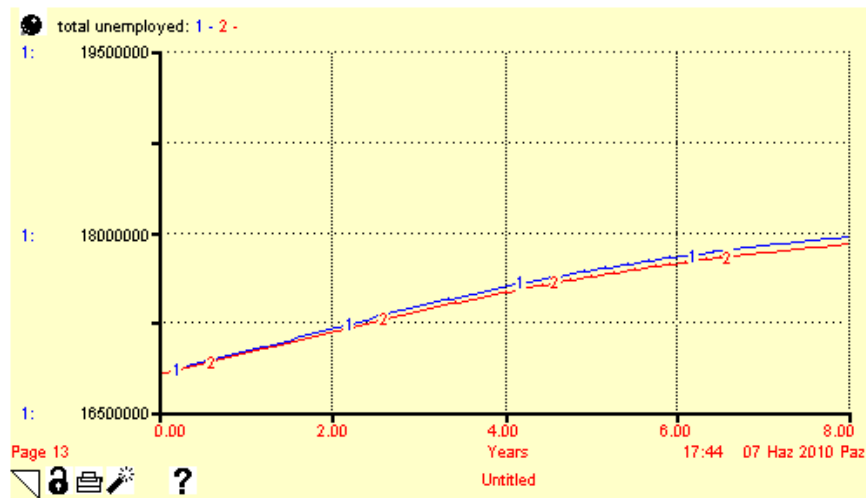

Figure 5.14: Policy 1 (Increasing the grad\_school\_enrollment two fold) Total Unemployment Result. -1-: Base-run. -2-: Policy applied

This means that there is room for more grad\_school graduates in the potential jobs yet. However, this decrease cannot continue permanently since the total number of potential jobs for grad\_school workers has a limit. And according to the over-education theory (see Section 4.2), those over educated workers and the resource used for their education will be wasted.

2. **Increasing the new\_academicians two fold:** This policy itself is not sufficient to have an additive effect on the GDP. Because the new academicians will be extracted from the grad\_school students stock. The number of grad\_school graduates, who are the potential researchers that are expected to have highest efficiency when they enter the labor sector, will be decreased. Although increasing the number of academicians has a positive effect on the education quality of higher education, positive improvement requires other policies together with it related to investment and potential students. The result can be seen in Figure 5.15.

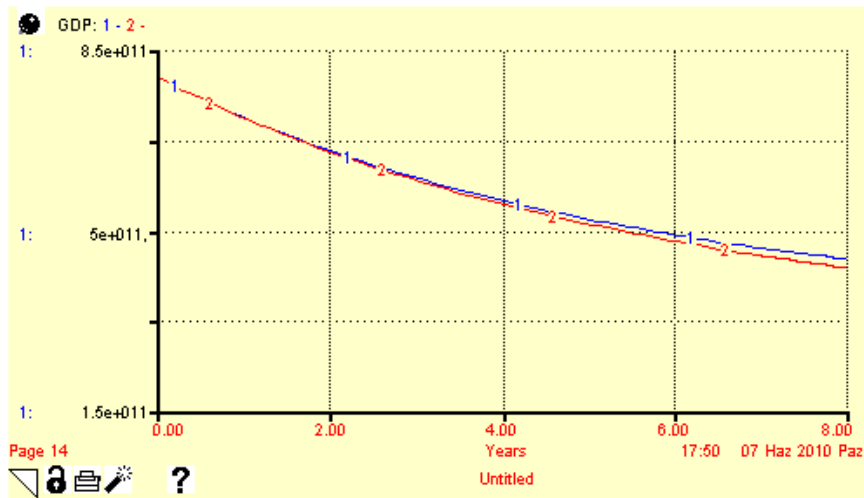

Figure 5.15: Policy 2 (Increasing the new\_academicians two fold) GDP Result. -1-: Base-run. -2-: Policy applied

This single policy does not lead to a reduction in total unemployment, since the new academicians used to have sufficient jobs according to their academic backgrounds in the labor sector. The result can be seen in Figure 5.16.

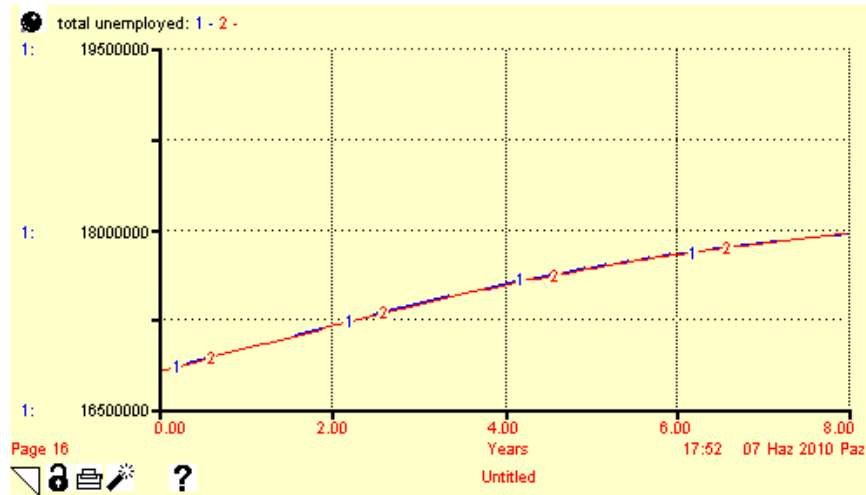

Figure 5.16: Policy 2 (Increasing the new\_academicians two fold) Total Unemployment Result. -1-: Base-run. -2-: Policy applied

3. **Increasing the university\_enrollment two fold:** Increasing the admission capacities of existing universities and establishing new universities are policies that come into question frequently in Turkey. They are not only in theory but also in practice, too. New state or private universities are founded continually and admission quotas of existing universities are extended. However, this strategy has many aspects that form an economic trade-off. According to the model, when the university enrollment is doubled, the GDP is affected negatively. The result can be seen in Figure 5.17.

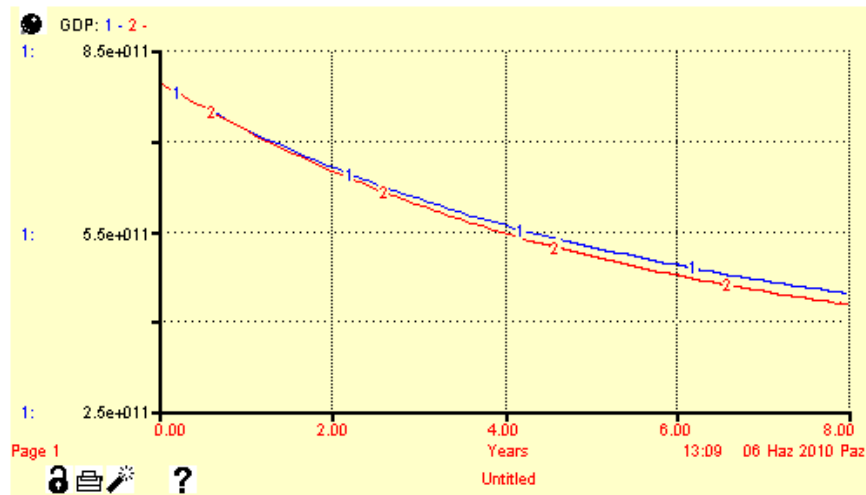

Figure 5.17: Policy 3 (Increasing the university\_enrollment two fold) GDP Result. -1-: Base-run. -2-: Policy applied

This policy also requires other simultaneous policies. In addition to that, accepting all the population into universities is not feasible. This result addresses the strategy of strengthening vocational high schools in order to bring out high\_school\_grad workers having higher efficiency. At the same time, it is seen that the labor market still has some room for new university graduates up to a point, but then the reduction in unemployment stops, with this single strategy. Total unemployment results can be seen in Figure 5.18.

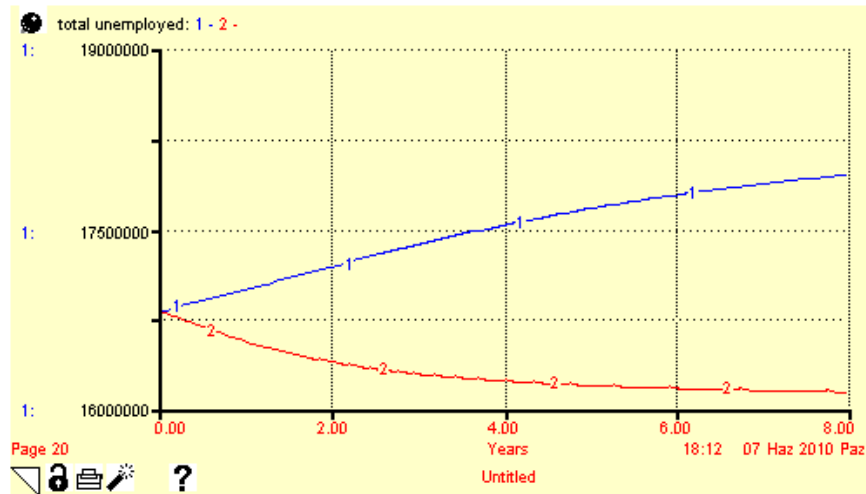

Figure 5.18: Policy 3 (Increasing the university\_enrollment two fold) Total Unemployment Result. -1-: Base-run. -2-: Policy applied

4. **Increasing the `acd_teach_factor` from 0.6 to 0.8:** The dual function (education and research) of academicians is a critical subject for higher education quality. One view argues that research function of the faculty supports their educational job. On the other hand, studies do not indicate any observable relation between the two activities [68]. In our model they are treated as two separate functions as in most of the literature. According to our model, increasing the percentage of time that academicians spend for education activities rather than research has a considerably positive effect on the GDP. The result can be seen in Figure 5.19.

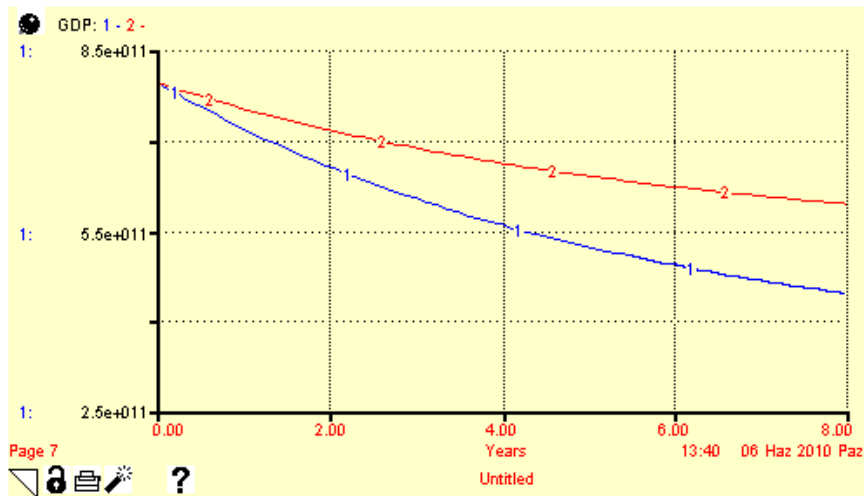

Figure 5.19: Policy 4 (Increasing the `acd_teach_factor` from 0.6 to 0.8) GDP Result. -1-: Base-run. -2-: Policy applied

Prince et.al. propose several suggestions for increasing the higher education quality without discarding research:

”Formally recognizing and rewarding faculty members who successfully integrate their teaching and research, establishing faculty development programs in both teaching and research including ways to integrate the two domains, promoting involvement in research for a broad spectrum of undergraduates, encouraging faculty members to use inductive teaching methods (e.g. inquiry-based, problem-based, and project-based learning); providing faculty development programs that prepare them to do so; assessing the effectiveness of the methods for integrating research and teaching, etc.” [68].

Since this policy leads to economic growth, new potential jobs emerge, so that the total unemployment is reduced. The result can be seen in Figure 5.20.

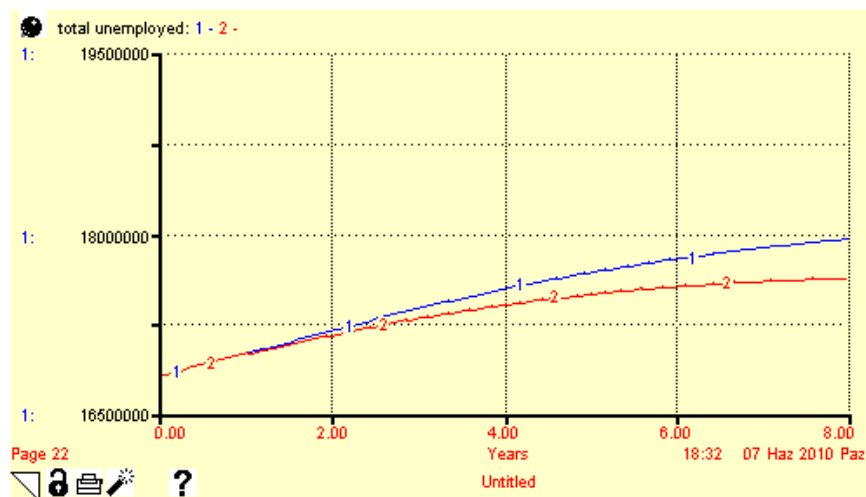

Figure 5.20: Policy 4 (Increasing the `acd_teach_factor` from 0.6 to 0.8) Total Unemployment Result. -1-: Base-run. -2-: Policy applied



5. **Increasing the Edu\_inv\_MoE\_ratio five fold:** This policy has a positive contribution to the economic growth. The result can be seen in Figure 5.21.

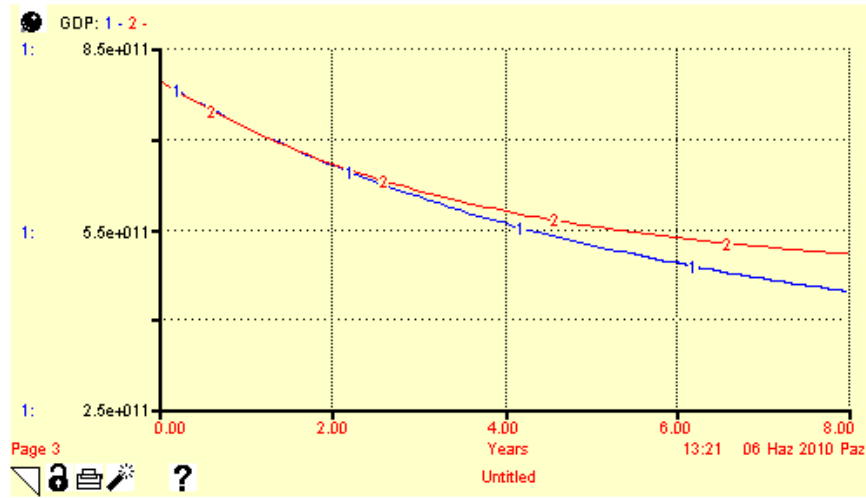

Figure 5.21: Policy 5 (Increasing the Edu\_inv\_MoE\_ratio five fold) GDP Result. -1-: Base-run. -2-: Policy applied

This investment is mostly important in determining the education quality level of non\_university graduate students. This result is expected, since many studies indicate the positive correlation between educational investment and economic growth. The Edu\_inv\_MoE ratio is raised from 0.04 to 0.2. The difference corresponds to \$ 127,076,480,000. It is set to be five times its current value in the scenario, since that nearly corresponds to the countries with highest educational spending per GDP in the world. This growth will be reflected as a reduction in unemployment with some delay as can be seen in Figure 5.22.

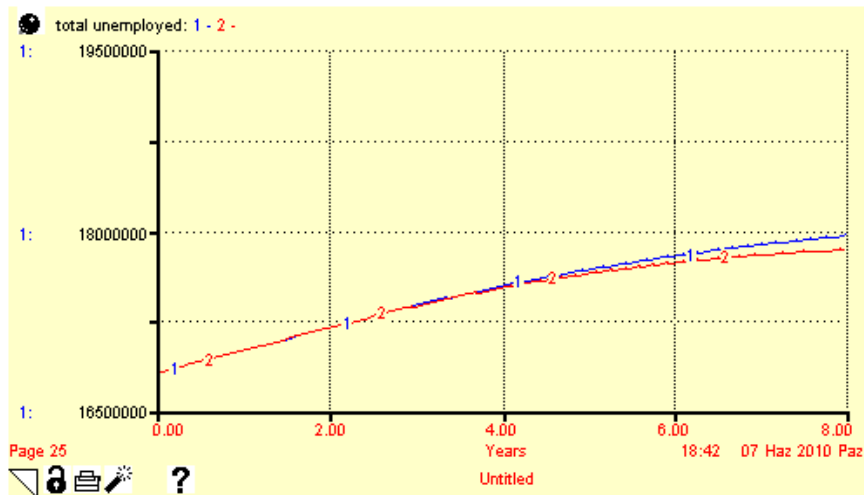

Figure 5.22: Policy 5 (Increasing the Edu\_inv\_MoE\_ratio five fold) Total Unemployment Result. -1-: Base-run. -2-: Policy applied

6. **Increasing the Edu\_inv\_CoHE\_ratio five fold:** This policy has also a positive contribution to the economic growth expectedly as in the previous case. The result can be seen in Figure 5.23.

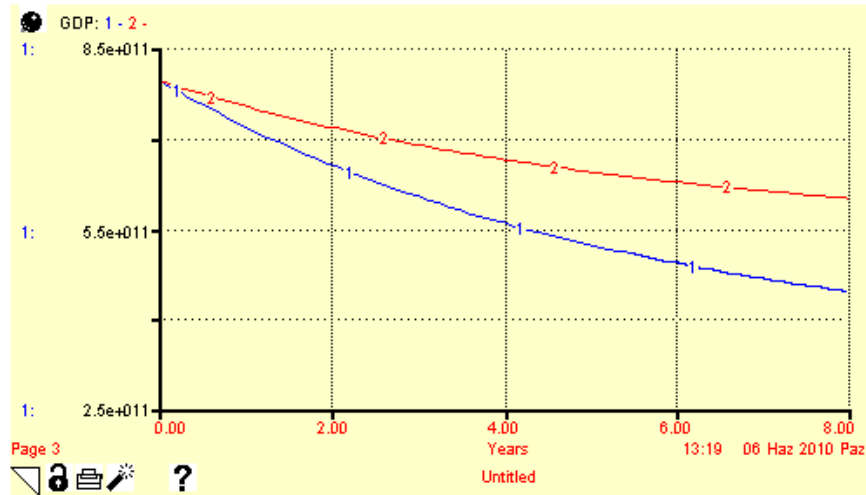

Figure 5.23: Policy 6 (Increasing the Edu\_inv\_CoHE\_ratio five fold) GDP Result. -1-: Base-run. -2-: Policy applied

The rationale behind selection of "five fold" is again the same as in the Edu\_inv\_MoE. The Edu\_inv\_CoHE ratio is raised from 0.1 to 0.5 in this case. This variation equals \$ 50,830,592,000. Although this increase is less than in policy 5, it is observed to have a greater effect in economic growth. And consequently, the reduction in total unemployment is faster than in policy 5, as can be seen in Figure 5.24.

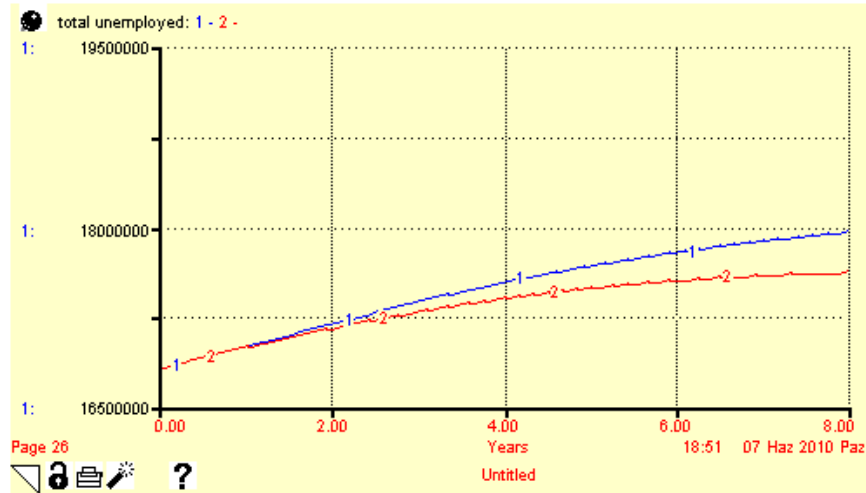

Figure 5.24: Policy 6 (Increasing the Edu\_inv\_CoHE\_ratio five fold) Total Unemployment Result. -1-: Base-run. -2-: Policy applied

7. **Increasing the Research\_inv\_ratio five fold:** Research investment ratio emerges as the most influential investment in increasing the economic growth. It is increased from 0.0073 to 0.0365. It means a \$ 23,191,457,600 more investment. Although this amount is less than the former two, it causes the highest leap in economic growth as can be seen in Figure 5.25.

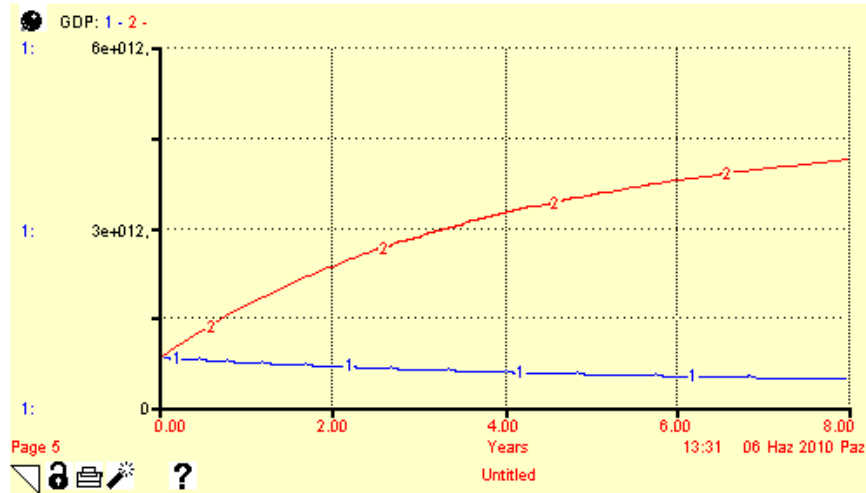

Figure 5.25: Policy 7 (Increasing the Research\_inv\_ratio five fold) GDP Result. -1-: Base-run. -2-: Policy applied

This growth ends up with a reduction in total unemployment as well. The result can be seen in Figure 5.26.

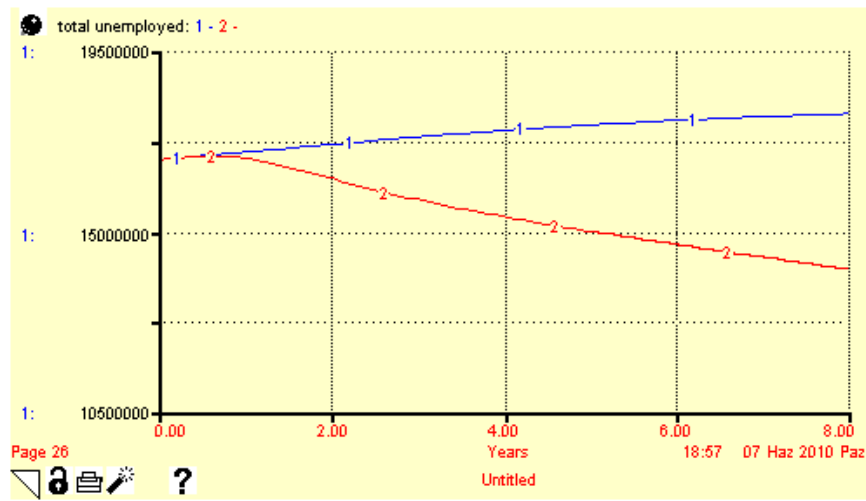

Figure 5.26: Policy 7 (Increasing the Research\_inv\_ratio five fold) Total Unemployment Result. -1-: Base-run. -2-: Policy applied

8. **Increasing the teacher\_grad\_rate two fold:** This policy means increasing the ratio of educational department graduates (potential teachers) in the total number of university graduates of the same period. It implies a reduction in the university graduates who are the potential workers for other sectors. However it has a direct relation with education quality of MoE. This policy has a positive effect in the GDP and the total unemployment value. Results can be seen in Figure 5.27 and Figure 5.27.

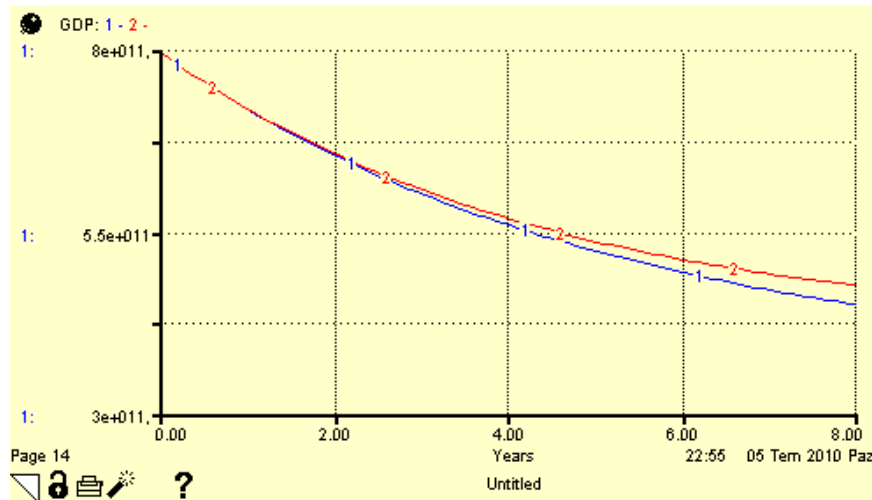

Figure 5.27: Policy 8 (Increasing the teacher\_grad\_rate two fold) GDP Result. -1-: Base-run. -2-: Policy applied

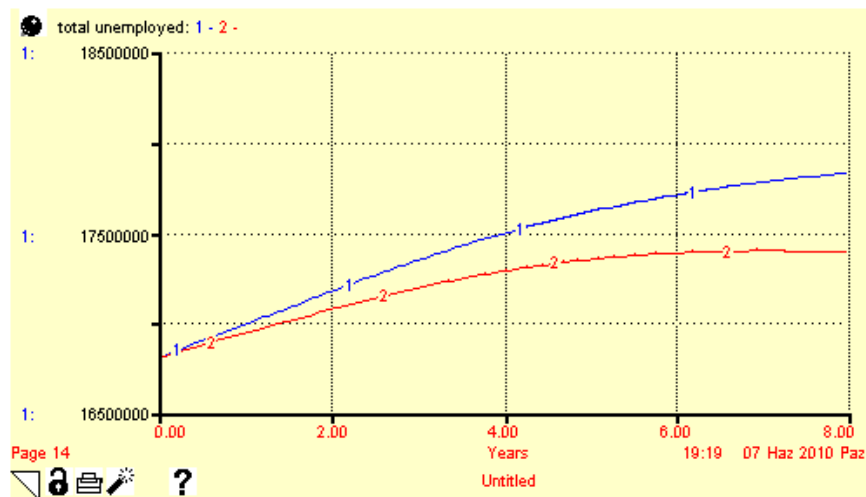

Figure 5.28: Policy 8 (Increasing the teacher\_grad\_rate two fold) Total Unemployment Result. -1-: Base-run. -2-: Policy applied

### 5.7.2.2 Combined Policy Analysis

Since single policies are of less influence for complex dynamical systems, suitable policy combinations are more worthy. [77] Combining more than one alternative is a way of improving solution strategies for the existing problems. In this part, we generate three combined policies:

1. **Increasing the edu\_inv\_CoHE\_ratio three fold, new\_academicians two fold and grad\_school\_enrollment by 4000:** This policy aims to strengthen higher education quality. In this policy, edu\_inv\_CoHE\_ratio is raised from 0.01 to 0.03, new academicians are raised from 4000 to 8000 and grad school enrollment is raised from 20000 to 24000. This 4000 increase in grad school enrollment aims to meet the new academicians. It is observed that, although increasing only the new\_academicians is not an effective policy; implementing it with other related policies makes it more effective. The results can be seen in Figure 5.29 and Figure 5.30.

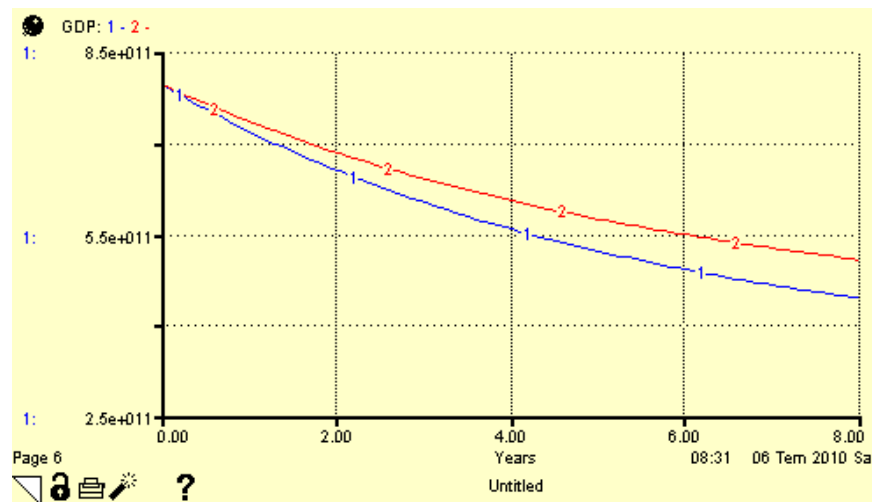

Figure 5.29: Combined Policy 1 (Increasing the edu\_inv\_CoHE\_ratio three fold, new\_academicians two fold and grad\_school\_enrollment by 4000) GDP Result. -1-: Base-run. -2-: Policy applied



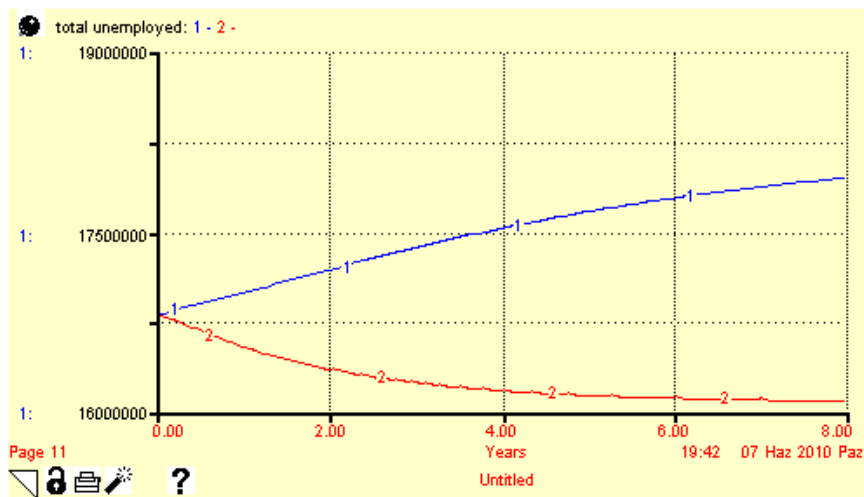

Figure 5.30: Combined Policy 1 (Increasing the edu\_inv\_CoHE\_ratio three fold, new\_academics two fold and grad\_school\_enrollment by 4000) Total Unemployment Result. -1-: Base-run. -2-: Policy applied

## 2. Increasing the new\_academics, edu\_inv\_CoHE\_ratio and res\_inv\_ratio two fold:

This policy is applied with the intention of reinforcing the research function of academics. By employing new\_academics, we get rid of increasing the acad\_teach\_factor strategy, so that academics can deal with more research. But employing new academics requires more investment in higher education. Finally, reinforcing the research function has a positive effect on the GDP as expected. The results can be seen in Figure 5.31 and Figure 5.32.

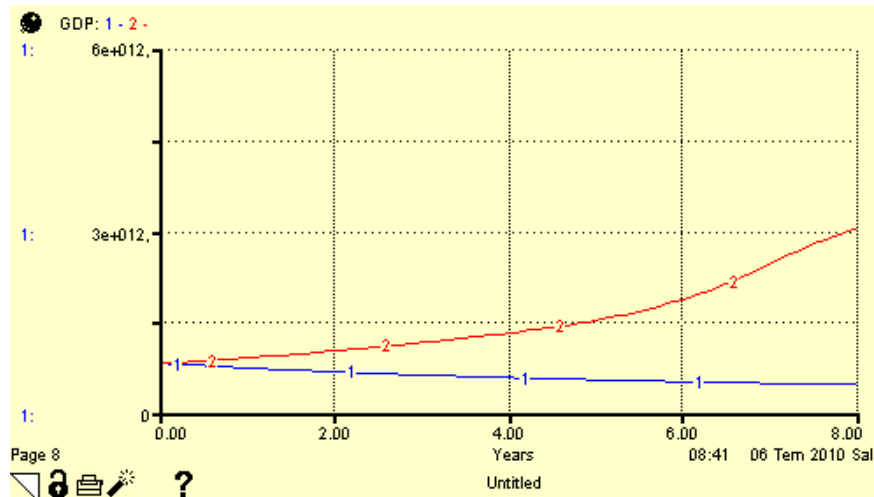

Figure 5.31: Combined Policy 2 (Increasing the new\_academics, edu\_inv\_CoHE\_ratio and res\_inv\_ratio two fold) GDP Result. -1-: Base-run. -2-: Policy applied

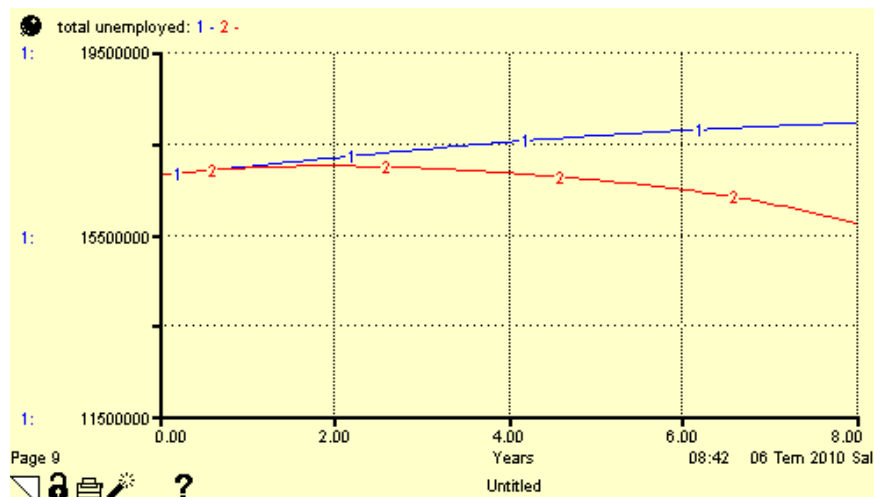

Figure 5.32: Combined Policy 2 (Increasing the new\_academics, edu\_inv\_CoHE\_ratio and res\_inv\_ratio two fold) Total Unemployment Result. -1-: Base-run. -2-: Policy applied

3. **Increasing the `acd_teach_factor` from 0.6 to 0.8 and increasing `teacher_grad_rate` and `new_academicians` two fold:** This policy serves increasing the educational staff both in primary and secondary schools, and in higher education. Expectedly, it has a favorable effect both in GDP values and in total unemployment. The results can be seen in Figure 5.33 and Figure 5.34.

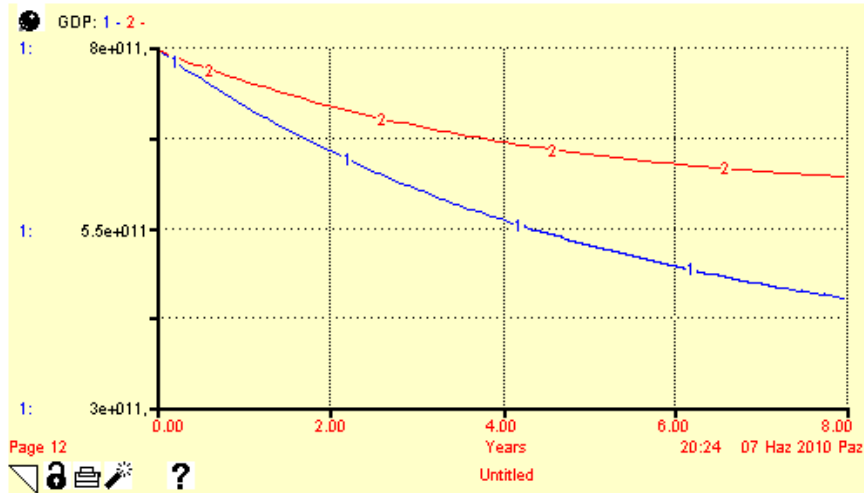

Figure 5.33: Combined Policy 3 (Increasing the `acd_teach_factor` from 0.6 to 0.8 and increasing `teacher_grad_rate` and `new_academicians` two fold) GDP Result. -1-: Base-run. -2-: Policy applied

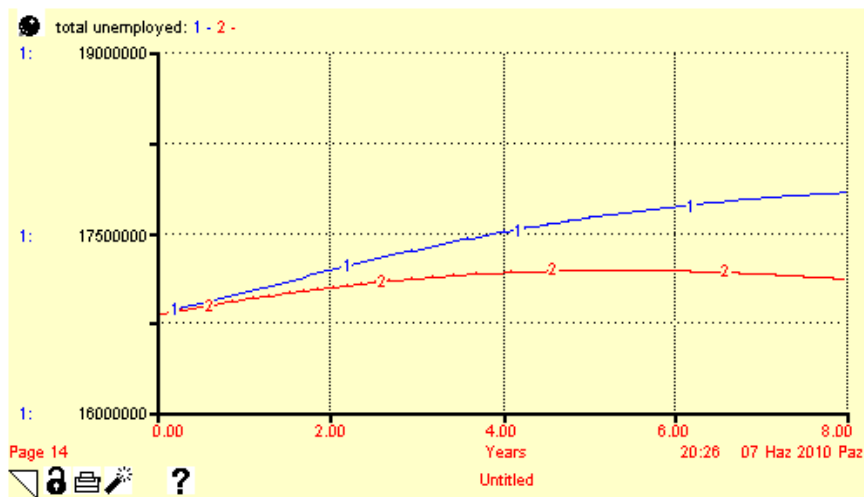

Figure 5.34: Combined Policy 3 (Increasing the `acd_teach_factor` from 0.6 to 0.8 and increasing `teacher_grad_rate` and `new_academicians` two fold) Total Unemployment Result. -1-: Base-run. -2-: Policy applied

## CHAPTER 6

### DISCUSSION AND CONCLUSION

The results show that some of the alternative policies have a point and some do not. The key findings of the model are:

- In the order of increasing impact, the national well being of Turkey is affected by investments in: *Primary and secondary education, Higher education and Total research.*
- Increasing the university enrollment quotas is not a reasonable policy. This observation has significant implications regarding strategies of establishing new universities and increasing enrollment capacities. Although the strategy may sound good, it may not necessarily be something to improve the country.
- Increasing the number of teachers is an efficient policy that increases the well being and decreases unemployment.
- Increasing the amount of time that academicians spend for educational activities rather than research, is an effective policy.
- Increasing the number of new academicians alone does not seem to be a good policy, since this means decreasing the graduate degree holder workers in our model. However, the policy can be put into use by performing other related moves at the same time.

With this study, we aimed to understand the way in which education affects economic growth. As mentioned in the literature, it is definitely hard to measure the effect of human capital to the economy. When there are infinitely many factors in real life that affect the economy, this model might seem too much simplistic. However, here we discuss the very fundamental

characteristics and determinants. The purpose of the study is not making exact predictions, but analyzing the complex relations by constructing a system that resembles the original system. The model is not supposed to remedy the education problem of Turkey by just a single Midas touch, such as "a single parameter change". Our point of focus is to query the mechanism of concern.

We proposed the Systems Dynamics methodology and tried to figure out how the quantitative estimates may influence the qualitative, and vice versa. We view that education, research, technology, employment, and the assets of the country are inseparable subjects and they constitute a complex dynamical system. Surely, there are distinct methods but we regarded this methodology as an appropriate tool that is worth trial. Our study verifies system dynamics as a methodology which has been a modeling tradition with various models on various areas. Suggesting the use of the methodology as a tool might evoke and give an idea to the possible future studies which might be more comprehensive.

Before creating the model, we presented the details of the methodology and a survey of modeling dynamics of education, research and manpower systems. The model is built as a deterministic one. For the future work, further runs may be conducted with more precise and detailed field data. Our study reveals that methods of measuring intangibles should be improved. In addition to that, the effect of other factors such as social factors, influence of globalization, brain drain, etc. might be examined. The model outcomes do not include personal views. All we speak of are the words according to the model. On the other hand, we are aware of the fact that questioning education in a pragmatic way (e.g. GDP as the performance indicator) can be another point of debate in another platform.

Finally, the fundamental issue in developmental policy making is to ensure sustainability. Those decision makers who make decisions on the future of countries (especially developing countries such as Turkey), should consult dynamical analysis in order to take action towards sustainable development. In case they perceive making policy and investment in science, education and research as negligible or pricy, they might make the future generations face with further limitations on their development in time.

## REFERENCES

- [1] CIA The World Fact Book. <https://www.cia.gov/library/publications/the-world-factbook/>. Last visited on May 2010.
- [2] Eğitim-Sen Bilgi-Belge. [http://www.egitimsen.org.tr/bilgi\\_belge.php](http://www.egitimsen.org.tr/bilgi_belge.php). Last visited on May 2010.
- [3] Statistics Norway. <http://www.ssb.no/en/>. Last visited on May 2010.
- [4] The World Bank Data. <http://data.worldbank.org/>. Last visited on May 2010.
- [5] TÜBİTAK Statistics. <http://tubitak.gov.tr/sid/357/index.htm> . Last visited on May 2010.
- [6] TÜİK. <http://www.tuik.gov.tr>. Last visited on May 2010.
- [7] Türk Patent Enstitüsü. <http://www.turkpatent.gov.tr/portal/default.jsp>. Last visited on May 2010.
- [8] UN Data. <http://data.un.org/>. Last visited on May 2010.
- [9] World Intellectual Property Organization. <http://www.wipo.int/portal/index.html.en>. Last visited on May 2010.
- [10] AB ve Türkiye'nin Geleceğinde İnovasyonun Önemi . <http://www.euractiv.com.tr/abnin-gelecegi/link-dossier/ab-ve-turkiyenin-geleceginde-inovasyonun-onemi-000064>. Last visited on June, 2010.
- [11] TÜBİTAK. <http://www.tubitak.gov.tr/>. Last visited on: June 2010.
- [12] The Natural Edge Project (TNEP). What are the Opportunities in 'Sustainability'? [http://www.naturaledgeproject.net/images/wavesofinnovationgraph\\_002.jpg](http://www.naturaledgeproject.net/images/wavesofinnovationgraph_002.jpg). Last visited on: May 2010.
- [13] Y. Barlas. Multiple tests for validation of system dynamics type of simulation models\* 1. *European Journal of Operational Research*, 42(1):59–87, 1989.
- [14] Y. Barlas. Model validation in system dynamics. In *Proceedings of the 1994 International System Dynamics Conference*, pages 1–10, 1994.
- [15] Y. Barlas. Formal aspects of model validity and validation in system dynamics. *System dynamics review*, 12(3):183–210, 1996.
- [16] Y. Barlas. System Dynamics: Systemic Feedback Modeling for Policy Analysis. *SYSTEM*, 1:59, 2007.
- [17] Y. Barlas and S. Carpenter. Philosophical roots of model validation: Two paradigms. *System Dynamics Review*, 6(2):148–166, 2006.

- [18] Y. Barlas and V.G. Diker. Decision Support for Strategic University Management: A Dynamic Interactive Game. In *Proceedings of the 14th International System Dynamics Conference, Cambridge, MA*, volume 1, pages 47–50, 1996.
- [19] Y. Barlas and V.G. Diker. A dynamic simulation game (UNIGAME) for strategic university management. *Simulation & Gaming*, 31(3):331, 2000.
- [20] L. Bertalanffy. An Outline of General System Theory. *The British Journal for the Philosophy of Science*, 1(2):134, 1950.
- [21] M. Blaug. Approaches to educational planning. *The Economic Journal*, 77(306):262–287, 1967.
- [22] P. Carl and D. Sawicki. *Basic Methods of Policy Analysis and Planning*. New Jersey: Prentice Hall, 1993.
- [23] Ö. Çakmak. The Influence of Education on Economy and Development . *D.U. Ziya Gökalp Eğitim Fakültesi Dergisi*, 11:33–41, 2008.
- [24] BİLGİ ÇAĞI. Ar-Ge ve yeniliği ölçmek: Türkiye’de Ar-Ge ve yenilik verileri . *BİLGİ ÇAĞI*, 41, 2008.
- [25] P. Checkland. *Systems thinking, systems practice*. Wiley Chichester, 1981.
- [26] H.G. Daellenbach. *Systems and decision making: a management science approach*. Wiley New York, 1994.
- [27] H.E. Daly, J.B. Cobb, and C.W. Cobb. *For the common good: Redirecting the economy toward community, the environment, and a sustainable future*. Beacon Pr, 1994.
- [28] UN Data. <http://data.un.org/documentdata.aspx?q=education+index&id=185>. Last visited on May 2010.
- [29] R. Descartes. *Discourse on method, and the meditations: by Descartes; translated with an introduction by FE Sutcliffe*. Penguin Books, 1968.
- [30] A REVIEW OF INDICATORS OF SUSTAINABLE DEVELOPMENT. <http://www.trp.dundee.ac.uk/library/pubs/set.html>. Last visited on: April 2010.
- [31] S.M. Durgun. A System Dynamics Approach for Technology Improvement Policy Analysis: The Case Of Turkey . Master’s thesis, METU, 2001.
- [32] Eğitim düzeyi düşük üçüncü OECD ülkesiyiz. [http://www.referansgazetesi.com/haber.aspx?hbr\\_kod=58276&ktg\\_kod=234&forarsiv=1](http://www.referansgazetesi.com/haber.aspx?hbr_kod=58276&ktg_kod=234&forarsiv=1). Last visited on: June 2010, 2007.
- [33] J.W. Forrester. Industrial dynamics. 1961. *Pegasus Communications*.
- [34] J.W. Forrester. Principles of systems, 1968.
- [35] J.W. Forrester. Counterintuitive Behavior of Social Systems. *Theory and Decision*, 2(2):109–140, 1971.



- [36] J.W. Forrester. Confidence in models of social behavior with emphasis on system dynamics models. *System Dynamics Group Working Paper D-1967*. Cambridge, MA: MIT, 1973.
- [37] J.W. Forrester. Collected papers of Jay W. Forrester, Pegasus Communications, Waltham, MA, 1975.
- [38] J.W. Forrester. System dynamics, systems thinking, and soft OR. *System*, 1994.
- [39] J.W. Forrester. Designing the future. *Work presented at Universidad de Sevilla*, 15, 1998.
- [40] J.W. Forrester. Dynamic models of economic systems and industrial organizations. *System Dynamics Review*, 19(4):329–345, 2004.
- [41] J.W. Forrester et al. *World dynamics*. Wright-Allen Press Cambridge, MA, 1971.
- [42] J.W. Forrester and P.M. Senge. Tests for building confidence in system dynamics models. *TIMS studies in the management sciences*, 14:209–228, 1980.
- [43] J.W. Forrester and P.M. Senge. Tests for building confidence in system dynamics models. *TIMS studies in the management sciences*, 14:209–228, 1980.
- [44] J.W. Forrester and J. Wright. *Urban dynamics*. MIT Press Cambridge, MA, 1969.
- [45] P.L. Galbraith. A Dynamic Model for A Federal System of Higher Education. *DYNAMICA*, 10(2), 1984.
- [46] WE Gates, RM Males, and JF Walker. Application of industrial dynamics concepts to decision making in environmental management. *Water Resources Research*, 6:1549–1558, 1970.
- [47] A.K. Graham. *Principles on the relationship between structure and behavior of dynamic systems*. PhD thesis, Massachusetts Institute of Technology, 1977.
- [48] MIT System Dynamics Group. *System Dynamics Roadmap Series*. Cambridge, Massachusetts, 2002.
- [49] Ç. Güven. Nasıl "İyi endüstri mühendisi" olunur? [http://www.sistems.org/iyi\\_em.htm](http://www.sistems.org/iyi_em.htm) Last visited on February 2010, 2001.
- [50] M.C. Jackson. *Systems approaches to management*. Kluwer Academic/Plenum Publishers, 2000.
- [51] M.C. Jackson. *Systems thinking: Creative holism for managers*. Wiley Chichester, 2003.
- [52] G. Johnes. Education and Economic Growth.
- [53] M. Kennedy. An extended Taxonomy of System Dynamics Models of Higher Education. In *2002 system dynamics conference paper*, 2002.
- [54] M. Kennedy and C. Clare. Some Issues in Building System Dynamics Models for improving the Resource Management Process in Higher Education. In *seventeenth International System Dynamics Conference, July*, pages 30–23, 1999.

- [55] A. Korkmaz. *Eğitimin Ekonomik Temelleri* . Nobel Yayınevi, Ankara, 2006.
- [56] T.L. Lee and N. Von Tunzelmann. A dynamic analytic approach to national innovation systems: the IC industry in Taiwan. *Research Policy*, 34(4):425–440, 2005.
- [57] N.J. Mass and P.M. Senge. Model Behavior Testing of Equation Specification in System Dynamics Models. *System Dynamics Group Working Paper D-2466-1*, 1976.
- [58] W.W. McMahon. Relative Returns to Human and Physical Capital in the US and Efficient Investment Strategies. *Economics of Education Review*, 10(4):283–296, 1991.
- [59] D.H. Meadows, D.L. Meadows, J. Randers, W.W. Behrens, and The Club of Rome. *The Limits to Growth*. Universe Books New York, 1972.
- [60] J. Morecroft. *Strategic modelling and business dynamics: a feedback systems approach*. Wiley, 2007.
- [61] Report of the World Commission on Environment and Development. <http://www.un.org/documents/ga/res/42/ares42-187.htm>. Last visited on: April 2010, 1987.
- [62] Statistics on Worldwide Patent Activities. . Technical report, 2007.
- [63] B. Oyo, D. Williams, and E. Barendsen. A System Dynamics Tool for Higher Education Funding and Quality Policy Analysis. In *Proceedings of the 24th International Conference of the System Dynamics Society*, 2008.
- [64] B. Özgül. A System Dynamics Model for A University Department . Master’s thesis, METU, 1981.
- [65] The System Dynamics Society Home Page. <http://www.systemdynamics.org/> . Last visited on: April 2010.
- [66] S.H. Park, S.M. Lee, S.N. Yoon, and S.J. Yeon. A dynamic manpower forecasting model for the information security industry. *INDUSTRIAL MANAGEMENT AND DATA SYSTEMS*, 108(3):368, 2008.
- [67] D.W. Peterson. Statistical Tools for System Dynamics. *Elements of the system dynamics method*, page 226, 1980.
- [68] M.J. Prince, R.M. Felder, and R. Brent. Does faculty research improve undergraduate teaching? An analysis of existing and potential synergies. *Journal of Engineering Education*, 96(4):283–294, 2007.
- [69] M. Quigley. The Economics of Education: is it Profitable to be Ignorant? In *Proceedings of the 2009 International Conference of the System Dynamics Society*, 2009.
- [70] F.L. Rivera-Batiz. ”Eğitim ve Ekonomik Kalkınma” Konferansı , 2010.
- [71] J. Robertson. The new economics of sustainable development, a briefing for policy makers, a report for the european commission. Presented to European Commission 1997. Initially published by Kogan Page for the European Commission, 1999.

- [72] L.L.R. Rodrigues and M.S. Martis. System Dynamics of Human Resource and Knowledge Management in Engineering Education. *Journal of Knowledge Management Practice*, 5, 2004.
- [73] W.W. Schroeder III. System Dynamics: A Unique Tool for Analyzing Data-deficient Social Systems. In *Modeling and simulation: proceedings of the annual Pittsburgh Conference*, page 66. Instrument Society of America, 1971.
- [74] P.M. Senge. The Fifth Discipline: The Art and Practice of the Learning Organization: Book review. *Consulting Psychology Journal: Practice and Research*, 45(4):31–32, 1993.
- [75] P.J. Sloane. 2. Much ado About Nothing? What does the Overeducation Literature Really Tell us? *Overeducation in Europe: current issues in theory and policy*, page 11, 2003.
- [76] W.H. Spearow. A Dynamic Model of the Work Force at the Naval Air Weapons Station China Lake . Master's thesis, NAVAL POSTGRADUATE SCHOOL MONTEREY CA, 2008.
- [77] J.D. Sterman. All models are wrong: reflections on becoming a systems scientist. *System Dynamics Review*, 18(4):501–531, 2002.
- [78] S.R. Sweetland. Human Capital Theory: Foundations of a Field of Inquiry. *Review of Educational Research*, 66(3):341, 1996.
- [79] C. Tank-Nielsen. Sensitivity analysis in system dynamics. *Elements of the system dynamics method*, pages 185–204, 1980.
- [80] A. Tansel. Determinants of School Attainment of Boys and Girls in Turkey: Individual, Household and Community Factors. *Economics of Education Review*, 21(5):455–470, 2002.
- [81] M.C. Tsang and H.M. Levin. The economics of overeducation. *Economics of Education Review*, 4(2):93–104, 1985.
- [82] Türkiye’de Araştırma-Geliştirme: Ne Durumdayız? Ne Yapmalıyız? <http://www.tisk.org.tr/yayinlar.asp?sbj=ic&id=2590>. Last visited on: June 2010.
- [83] F. Türkmen. *A Comprehensive Study on Education DPT* . DPT, Ankara, 1999.
- [84] F. Türkmen. *Eğitimin Ekonomik ve Sosyal Faydaları ve Türkiye’de Eğitim Ekonomik Büyüme İlişkisinin Araştırılması* . DPT - UZMANLIK TEZLERİ, YAYIN NO: DPT: 2655, 2002.
- [85] C.G. Williams. *Labor Economics*. John Wiley & Sons, 1970.
- [86] K. Yamaç. *Bilgi Toplumu ve Üniversiteler*. Eflatun Yayınevi. ISBN: 987-605-4160-28-0, 2009.
- [87] B. Yıldız, H. Ilgaz, and S.S. Seferoğlu. Türkiye’de Bilim ve Teknoloji Politikaları: 1963’den 2013’e Kalkınma Planlarına Genel Bir Bakış . In *Akademik Bilişim*, 2010.
- [88] K. Yurtseven. Sistem Düşüncesi ve Sistem Dinamikleri . In *6th Convention of System Engineers*. Ankara, 2009.

# Appendix A

## MODEL VARIABLES

### A.1 Stocks

Table A.1: Stocks

academicians
GDP_lagged
grad_school_grads_unemp
grad_school_grads__workers
grad_school_students
high_school_students
non_uni_grads_unemp
non_uni_grads__workers
population_lagged
potential_jobs
Preschool_children
primary_school_students
retired_academician
retired_grad_school_grad
retired_non_uni_grad
retired_teachers
retired_uni_grad
teachers
temporary_annual__GDP_pool
university_students
uni_grads_unemp
uni_grad__workers

## A.2 Flows

Table A.2: Flows

births
deaths_academician
deaths_grad_school
deaths_high_school
deaths_preschool
deaths_primary_school
deaths_retired_academician
deaths_retired_uni_grad
deaths_teachers
deaths_university
deaths__grad_school_grad
deaths__grad_school_grads_unemp
deaths__grad_school_grad_workers
deaths__non_uni_grads_unemp
deaths__non_uni_grads_workers
deaths__retired_non_uni_grad
deaths__retired_teacher
deaths__uni_grads_unemp
deaths__uni_grad_workers
GDP
grad_school_enrollment
grad_school_grads__employment
grad_school_grads__quit_or_dismissal
high_school_enrollment
leaving_academy__after_grad_school
leaving_edu__after_high_school
leaving_edu__after_primary_school
leaving_edu__after_university
new_academics
new_jobs
non_uni_grads__employment

Table A.3: Flows - 2

non_uni_grad_quit_or_dismissal
old_jobs
population_lag
primary_school_enrollment
retiring_academician
retiring_non_uni_grad
retiring_teachers
retiring_uni_grad
retiring_grad_school_grad
spending
total_GDP
total_pop
university_enrollment
uni_grads_quit_or_dismissal
uni_grads_employment
uni_grad_teachers

### A.3 Converters

Table A.4: Converters

academic_researcher
academic_teacher
acad_research_investment
acad_res_inv_ratio
acd_res_factor
acd_teacher_per_student_CoHE
acd_tea_factor
all_workers
birth_rate
CoHE_students
economic_growth
education_investment_CoHE
education_investment_MoE
education_inv_CoHE_ratio
edu_inv_MoE_ratio
edu_inv_per_student_CoHE
edu_inv_per_student_MoE
GDP_person
grad_school_grad_efficiency
grad_school_grad_job_ratio
grad_uni
high_school_enrollment_factor
inv_researcher
max_output
MoE_students
mortality
mortal_0_to_5
non_uni_grad_efficiency
non_uni_grad_job_ratio
norm_other_sec_inv_all_workers
norm_patent_per_1000_population
old_workers
other_sectors_investment

Table A.5: Converters - 2

other_sectors_research_investment
other_sectors_investment_ratio
other_sectors_research_staff
other_sectors_res_inv_ratio
other_sec_inv_all_workers
quit_or_dismissal_rate
Recruits
researcher_worker_ratio
researcher_inv_ratio
std_edu_quality_factor_non_uni
std_edu_quality_factor_uni
std_edu_quality_factor_grad
teacher_per_student_MoE
tech_indicator
total_death_workers
total_output
total_output_grad_school_grad
total_output_non_uni_grad
total_output_uni_grad
TOTAL_POPULATION
total_researchers
total_research_investment
total_retired
total_retirement
total_unemployed
total_quit_or_dismissal
unit_output_grad_school_grad
unit_output_non_uni_grad
unit_output_uni_grad
uni_grad_efficiency
uni_grad_job_ratio
Uni_non_uni
Uni_non_uni
edu_quality_factor_CoHE
edu_quality_factor_MoE
patent_per_1000_population
teacher_grad_rate



## Appendix B

### MODEL EQUATIONS

$$\begin{aligned} \textit{academicians}(t) &= \textit{academicians}(t - dt) + \\ &(\textit{new\_academicians} - \textit{deaths\_academician} - \textit{retiring\_academician}) * dt \end{aligned}$$

$$\textit{INIT academicians} = 100000$$

*INFLOWS :*

$$\textit{new\_academicians} = 4000$$

*OUTFLOWS :*

$$\textit{deaths\_academician} = \textit{academicians} * \textit{mortality}$$

$$\textit{retiring\_academician} = \textit{academicians} * (1 - \textit{mortality})/25$$

$$\textit{GDP\_lagged}(t) = \textit{GDP\_lagged}(t - dt) + (\textit{total\_GDP} - \textit{GDP}) * dt$$

$$\textit{INIT GDP\_lagged} = 794228000000$$

*INFLOWS :*

$$\textit{total\_GDP} = \textit{total\_output}$$

*OUTFLOWS :*

$$\textit{GDP} = \textit{GDP\_lagged}$$

$$\begin{aligned} \textit{grad\_school\_grads\_unemp}(t) &= \textit{grad\_school\_grads\_unemp}(t - dt) + \\ &(\textit{leaving\_academy\_after\_grad\_scool} + \textit{grad\_school\_grads\_quit\_or\_dismissal} - \\ &\textit{deaths\_grad\_school\_grads\_unemp} - \textit{grad\_school\_grads\_employment}) * dt \end{aligned}$$

$$\textit{INIT grad\_school\_grads\_unemp} = 200200$$

*INFLOWS :*

$$\begin{aligned} \textit{leaving\_academy\_after\_grad\_scool} &= (\textit{grad\_school\_students} * (1 - \textit{mortality})/5) - \\ &\textit{new\_academicians} \end{aligned}$$

$$\begin{aligned} \textit{grad\_school\_grads\_quit\_or\_dismissal} &= \textit{grad\_school\_grad\_workers} * \\ &(1 - \textit{mortality}) * \textit{quit\_or\_dismissal\_rate} \end{aligned}$$

*OUTFLOWS :*

$$deaths\_grad\_school\_grads\_unemp = grad\_school\_grads\_unemp * mortality$$

$$grad\_school\_grads\_employment = potential\_jobs * grad\_school\_grad\_job\_ratio$$

$$grad\_school\_grad\_workers(t) = grad\_school\_grad\_workers(t - dt) + \\ (grad\_school\_grads\_employment - grad\_school\_grads\_quit\_or\_dismissal - \\ deaths\_grad\_school\_grad\_workers - retiring\_grad\_school\_grad) * dt$$

$$INIT grad\_school\_grad\_workers = 720000$$

*INFLOWS :*

$$grad\_school\_grads\_employment = potential\_jobs * grad\_school\_grad\_job\_ratio$$

*OUTFLOWS :*

$$grad\_school\_grads\_quit\_or\_dismissal = grad\_school\_grad\_workers * \\ (1 - mortality) * quit\_or\_dismissal\_rate$$

$$deaths\_grad\_school\_grad\_workers = grad\_school\_grad\_workers * mortality$$

$$retiring\_grad\_school\_grad = grad\_school\_grad\_workers * (1 - mortality)/25$$

$$grad\_school\_students(t) = grad\_school\_students(t - dt) + (grad\_school\_enrollment - \\ deaths\_grad\_school -$$

$$leaving\_academy\_after\_grad\_scool - new\_academicians) * dt$$

$$INIT grad\_school\_students = 120000$$

*INFLOWS :*

$$grad\_school\_enrollment = 20000$$

*OUTFLOWS :*

$$deaths\_grad\_school = grad\_school\_students * mortality$$

$$leaving\_academy\_after\_grad\_scool = (grad\_school\_students * (1 - mortality)/5) \\ - new\_academicians$$

$$new\_academicians = 4000$$

$$high\_school\_students(t) = high\_school\_students(t - dt) + (high\_school\_enrollment - \\ deaths\_high\_school - university\_enrollment -$$

$$leaving\_edu\_after\_high\_school) * dt$$

$$INIT high\_school\_students = 4500000$$

*INFLOWS :*

$$high\_school\_enrollment = (primary\_school\_students * (1 - mortality)/8) * \\ high\_school\_enrollment\_factor$$

*OUTFLOWS :*

$deaths\_high\_school = high\_school\_students * mortality$   
 $university\_enrollment = 500000$   
 $leaving\_edu\_after\_high\_school = (high\_school\_students * (1 - mortality))/4$   
 $- university\_enrollment$   
 $non\_uni\_grads\_unemp(t) = non\_uni\_grads\_unemp(t - dt) +$   
 $(leaving\_edu\_after\_primary\_school + leaving\_edu\_after\_high\_school +$   
 $non\_uni\_grad\_quit\_or\_dismissal - deaths\_non\_uni\_grads\_unemp -$   
 $non\_uni\_grads\_employment) * dt$   
 $INIT non\_uni\_grads\_unemp = 15796100$   
**INFLOWS :**  
 $leaving\_edu\_after\_primary\_school = (primary\_school\_students * (1 - mortality))/8 -$   
 $high\_school\_enrollment$   
 $leaving\_edu\_after\_high\_school = (high\_school\_students * (1 - mortality))/4 -$   
 $university\_enrollment$   
 $non\_uni\_grad\_quit\_or\_dismissal = non\_uni\_grad\_workers * (1 - mortality) *$   
 $quit\_or\_dismissal\_rate$   
**OUTFLOWS :**  
 $deaths\_non\_uni\_grads\_unemp = non\_uni\_grads\_unemp * mortality$   
 $non\_uni\_grads\_employment = potential\_jobs * non\_uni\_grad\_job\_ratio$   
 $non\_uni\_grad\_workers(t) = non\_uni\_grad\_workers(t - dt) +$   
 $(non\_uni\_grads\_employment - non\_uni\_grad\_quit\_or\_dismissal -$   
 $deaths\_non\_uni\_grad\_workers - retiring\_non\_uni\_grad) * dt$   
 $INIT non\_uni\_grad\_workers = 20000000$   
**INFLOWS :**  
 $non\_uni\_grads\_employment = potential\_jobs * non\_uni\_grad\_job\_ratio$   
**OUTFLOWS :**  
 $non\_uni\_grad\_quit\_or\_dismissal = non\_uni\_grad\_workers * (1 - mortality) *$   
 $quit\_or\_dismissal\_rate$   
 $deaths\_non\_uni\_grad\_workers = non\_uni\_grad\_workers * mortality$   
 $retiring\_non\_uni\_grad = non\_uni\_grad\_workers * (1 - mortality)/25$   
 $population\_lagged(t) = population\_lagged(t - dt) + (total\_pop -$   
 $population\_lag) * dt$   
 $INIT population\_lagged = 70600000$

*INFLOWS :*

*total\_pop = TOTAL\_POPULATION*

*OUTFLOWS :*

*population\_lag = population\_lagged*

*potential\_jobs(t) = potential\_jobs(t - dt) + (new\_jobs - old\_jobs) \* dt*

*INIT potential\_jobs = 1000000*

*INFLOWS :*

*new\_jobs = economic\_growth \* old\_workers*

*OUTFLOWS :*

*old\_jobs = recruits*

*Preschool\_children(t) = Preschool\_children(t - dt) + (births - deaths\_preschool - primary\_school\_enrollment) \* dt*

*INIT Preschool\_children = 4500000*

*INFLOWS :*

*births = birth\_rate \* TOTAL\_POPULATION*

*OUTFLOWS :*

*deaths\_preschool = Preschool\_children \* mortal\_0\_to\_5*

*primary\_school\_enrollment = Preschool\_children \* (1 - mortal\_0\_to\_5)/5*

*primary\_school\_students(t) = primary\_school\_students(t - dt) + (primary\_school\_enrollment - deaths\_primary\_school - high\_school\_enrollment - leaving\_edu\_after\_primary\_school) \* dt*

*INIT primary\_school\_students = 11000000*

*INFLOWS :*

*primary\_school\_enrollment = Preschool\_children \* (1 - mortal\_0\_to\_5)/5*

*OUTFLOWS :*

*deaths\_primary\_school = primary\_school\_students \* mortality*

*high\_school\_enrollment = (primary\_school\_students \* (1 - mortality)/8) \* high\_school\_enrollment\_factor*

*high\_school\_enrollment\_factor*

*leaving\_edu\_after\_primary\_school = (primary\_school\_students \* (1 - mortality)/8) - high\_school\_enrollment*

*retired\_academician(t) = retired\_academician(t - dt) +*

*(retiring\_academician - deaths\_retired\_academician) \* dt*

*INIT retired\_academician = 40000*

*INFLOWS :*

$$\text{retiring\_academician} = \text{academicians} * (1 - \text{mortality})/25$$

*OUTFLOWS :*

$$\text{deaths\_retired\_academician} = \text{retired\_academician} * \text{mortality}$$

$$\text{retired\_grad\_school\_grad}(t) = \text{retired\_grad\_school\_grad}(t - dt) + (\text{retiring\_grad\_school\_grad} - \text{deaths\_grad\_school\_grad}) * dt$$

$$\text{INIT retired\_grad\_school\_grad} = 52000$$

*INFLOWS :*

$$\text{retiring\_grad\_school\_grad} = \text{grad\_school\_grad\_workers} * (1 - \text{mortality})/25$$

*OUTFLOWS :*

$$\text{deaths\_grad\_school\_grad} = \text{retired\_grad\_school\_grad} * \text{mortality}$$

$$\text{retired\_non\_uni\_grad}(t) = \text{retired\_non\_uni\_grad}(t - dt) + (\text{retiring\_non\_uni\_grad} - \text{deaths\_retired\_non\_uni\_grad}) * dt$$

$$\text{INIT retired\_non\_uni\_grad} = 7650000$$

*INFLOWS :*

$$\text{retiring\_non\_uni\_grad} = \text{non\_uni\_grad\_workers} * (1 - \text{mortality})/25$$

*OUTFLOWS :*

$$\text{deaths\_retired\_non\_uni\_grad} = \text{retired\_non\_uni\_grad} * \text{mortality}$$

$$\text{retired\_teachers}(t) = \text{retired\_teachers}(t - dt) + (\text{retiring\_teachers} - \text{deaths\_retired\_teacher}) * dt$$

$$\text{INIT retired\_teachers} = 270000$$

*INFLOWS :*

$$\text{retiring\_teachers} = \text{teachers} * (1 - \text{mortality})/25$$

*OUTFLOWS :*

$$\text{deaths\_retired\_teacher} = \text{retired\_teachers} * \text{mortality}$$

$$\text{retired\_uni\_grad}(t) = \text{retired\_uni\_grad}(t - dt) + (\text{retiring\_uni\_grad} - \text{deaths\_retired\_uni\_grad}) * dt$$

$$\text{INIT retired\_uni\_grad} = 988000$$

*INFLOWS :*

$$\text{retiring\_uni\_grad} = \text{uni\_grad\_workers} * (1 - \text{mortality})/25$$

*OUTFLOWS :*

$$\text{deaths\_retired\_uni\_grad} = \text{retired\_uni\_grad} * \text{mortality}$$

$$\text{teachers}(t) = \text{teachers}(t - dt) + (\text{uni\_grad\_teachers} -$$

$$\text{retiring\_teachers} - \text{deaths\_teachers}) * dt$$

$$\text{INIT teachers} = 600000$$

INFLOWS :

$$\text{uni\_grad\_teachers} = \text{leaving\_edu\_after\_university} * \text{teacher\_grad\_rate}$$

OUTFLOWS :

$$\text{retiring\_teachers} = \text{teachers} * (1 - \text{mortality})/25$$

$$\text{deaths\_teachers} = \text{teachers} * \text{mortality}$$

$$\text{temporary\_annual\_GDP\_pool}(t) = \text{temporary\_annual\_GDP\_pool}(t - dt) + (\text{GDP} - \text{spending}) * dt$$

$$\text{INIT temporary\_annual\_GDP\_pool} = 0$$

INFLOWS :

$$\text{GDP} = \text{GDP\_lagged}$$

OUTFLOWS :

$$\text{spending} = \text{educational\_investment\_CoHE} + \text{educational\_investment\_MoE} + \text{other\_sectors\_investment} + \text{total\_research\_investment}$$

$$\text{university\_students}(t) = \text{university\_students}(t - dt) +$$

$$(\text{university\_enrollment} - \text{deaths\_university} - \text{leaving\_edu\_after\_university} - \text{grad\_school\_enrollment}) * dt$$

$$\text{INIT university\_students} = 2000000$$

INFLOWS :

$$\text{university\_enrollment} = 500000$$

OUTFLOWS :

$$\text{deaths\_university} = \text{university\_students} * \text{mortality}$$

$$\text{leaving\_edu\_after\_university} =$$

$$(\text{university\_students} * (1 - \text{mortality})/4) - \text{grad\_school\_enrollment}$$

$$\text{grad\_school\_enrollment} = 20000$$

$$\text{uni\_grads\_unemp}(t) = \text{uni\_grads\_unemp}(t - dt) +$$

$$(\text{leaving\_edu\_after\_university} + \text{uni\_grads\_quit\_or\_dismissal} - \text{deaths\_uni\_grads\_unemp} - \text{uni\_grad\_teachers} - \text{uni\_grads\_employment}) * dt$$

$$\text{INIT uni\_grads\_unemp} = 800800$$

INFLOWS :

$$\text{leaving\_edu\_after\_university} = (\text{university\_students} * (1 - \text{mortality})/4) - \text{grad\_school\_enrollment}$$

$uni\_grads\_quit\_or\_dismissal = uni\_grad\_workers * (1 - mortality) * quit\_or\_dismissal\_rate$

*OUTFLOWS :*

$deaths\_uni\_grads\_unemp = uni\_grads\_unemp * mortality$

$uni\_grad\_teachers = leaving\_edu\_after\_university * teacher\_grad\_rate$

$uni\_grads\_employment = potential\_jobs * uni\_grad\_job\_ratio$

$uni\_grad\_workers(t) = uni\_grad\_workers(t - dt) + (uni\_grads\_employment - uni\_grads\_quit\_or\_dismissal - deaths\_uni\_grad\_workers - retiring\_uni\_grad) * dt$

*INIT*  $uni\_grad\_workers = 2180000$

*INFLOWS :*

$uni\_grads\_employment = potential\_jobs * uni\_grad\_job\_ratio$

*OUTFLOWS :*

$uni\_grads\_quit\_or\_dismissal = uni\_grad\_workers * (1 - mortality) * quit\_or\_dismissal\_rate$

$deaths\_uni\_grad\_workers = uni\_grad\_workers * mortality$

$retiring\_uni\_grad = uni\_grad\_workers * (1 - mortality) / 25$

$academic\_researcher = academicians * acad\_res\_factor$

$academic\_teacher = academicians * acad\_tea\_factor$

$acad\_research\_investment = acad\_res\_inv\_ratio * total\_research\_investment$

$acad\_res\_inv\_ratio = 0.442$

$acad\_res\_factor = 1 - acad\_tea\_factor$

$acad\_teacher\_per\_student\_CoHE = academic\_teacher / CoHE\_students$

$acad\_tea\_factor = 0.6$

$all\_workers = grad\_school\_grad\_workers + non\_uni\_grad\_workers + uni\_grad\_workers$

$birth\_rate = 0.01866$

$CoHE\_students = grad\_school\_students + university\_students$

$economic\_growth = IF(TIME = 0) THEN 1 ELSE GDP / HISTORY(GDP, TIME-1)$

$educational\_investment\_CoHE = GDP * edu\_inv\_CoHE\_ratio$

$educational\_investment\_MoE = GDP * edu\_inv\_MoE\_ratio$

$edu\_inv\_CoHE\_ratio = 0.01$

$edu\_inv\_MoE\_ratio = 0.04$

$edu\_inv\_per\_student\_CoHE = educational\_investment\_CoHE / CoHE\_students$   
 $edu\_inv\_per\_student\_MoE = educational\_investment\_MoE / MoE\_students$   
 $GDP\_per\_person = GDP / population\_lag$   
 $grad\_school\_grad\_efficiency = (norm\_other\_sec\_inv\_all\_workers + tech\_indicator + std\_edu\_quality\_factor\_grad) / 3$   
 $grad\_school\_grad\_job\_ratio = 0.03$   
 $grad\_uni = 19 / 16$   
 $high\_school\_enrollment\_factor = 0.85$   
 $inv\_researcher = total\_research\_investment / total\_researchers$   
 $max\_output = 175000$   
 $MoE\_students = high\_school\_students + primary\_school\_students$   
 $mortality = 0.0059$   
 $mortal\_0\_to\_5 = 0.022$   
 $non\_uni\_grad\_efficiency = (norm\_other\_sec\_inv\_all\_workers + tech\_indicator + std\_edu\_quality\_factor\_non\_uni) / 3$   
 $non\_uni\_grad\_job\_ratio = 1 - (grad\_school\_grad\_job\_ratio + uni\_grad\_job\_ratio)$   
 $norm\_other\_sec\_inv\_all\_workers = other\_sec\_inv\_all\_workers / 89400$   
 $norm\_patent\_per\_1000\_population = patent\_per\_1000\_population / 0.264$   
 $old\_workers = total\_death\_workers + total\_retirement + total\_quit\_or\_dismissal$   
 $other\_sectors\_investment = GDP * other\_sectors\_investment\_ratio$   
 $other\_sectors\_research\_investment = other\_sectors\_res\_inv\_ratio * total\_research\_investment$   
 $other\_sectors\_investment\_ratio = 1 - (edu\_inv\_CoHE\_ratio + edu\_inv\_MoE\_ratio + research\_inv\_ratio)$   
 $other\_sectors\_research\_staff = all\_workers * researcher\_worker\_ratio$   
 $other\_sectors\_res\_inv\_ratio = 1 - acad\_res\_inv\_ratio$   
 $other\_sec\_inv\_all\_workers = other\_sectors\_investment / all\_workers$   
 $quit\_or\_dismissal\_rate = 0.002$   
 $recruits = grad\_school\_grads\_employment + non\_uni\_grads\_employment + uni\_grads\_employment$   
 $researcher\_worker\_ratio = 0.0025$



*research\_inv\_ratio* = 0.0073  
*std\_edu\_quality\_factor\_non\_uni* = (*edu\_quality\_factor\_MoE* /  
*Uni\\_non\_uni*) / *grad\\_uni*  
*std\_edu\_quality\_factor\_uni* = *edu\_quality\_factor\_CoHE* / *grad\\_uni*  
*std\_edu\_quality\_factor\_grad* = *edu\_quality\_factor\_CoHE*  
*teacher\_per\_student\_MoE* = *teachers/MoE\_students*  
*tech\_indicator* = *norm\_patent\_per\_1000\_population*  
*total\_death\_workers* = *deaths\_grad\_school\_grad\_workers* +  
*deaths\_non\_uni\_grad\_workers* + *deaths\_uni\_grad\_workers*  
*total\_output* = *total\_output\_grad\_school\_grad* + *total\_output\_non\_uni\_grad* +  
*total\_output\_uni\_grad*  
*total\_output\_grad\_school\_grad* = *grad\_school\_grad\_workers* \*  
*unit\_output\_grad\_school\_grad*  
*total\_output\_non\_uni\_grad* = *non\_uni\_grad\_workers* \* *unit\_output\_non\_uni\_grad*  
*total\_output\_uni\_grad* = *uni\_grad\_workers* \* *unit\_output\_uni\_grad*  
*TOTAL\_POPULATION* = *academicians* + *Preschool\_children* + *teachers* + *all\_workers* +  
*CoHE\_students* + *MoE\_students* + *total\_retired* + *total\_unemployed*  
*total\_researchers* = *academic\_researcher* + *other\_sectors\_research\_staff*  
*total\_research\_investment* = *GDP* \* *research\_inv\_ratio*  
*total\_retired* = *retired\_academician* + *retired\_grad\_school\_grad* + *retired\_non\_uni\_grad* +  
*retired\_teachers* + *retired\_uni\_grad*  
*total\_retirement* = *retiring\_non\_uni\_grad* + *retiring\_uni\_grad* +  
*retiring\_grad\_school\_grad*  
*total\_unemployed* = *grad\_school\_grads\_unemp* + *non\_uni\_grads\_unemp* + *uni\_grads\_unemp*  
*total\_quit\_or\_dismissal* = *grad\_school\_grads\_quit\_or\_dismissal* +  
*non\_uni\_grad\_quit\_or\_dismissal* + *uni\_grads\_quit\_or\_dismissal*  
*unit\_output\_grad\_school\_grad* = *grad\_school\_grad\_efficiency* \* *max\_output*  
*unit\_output\_non\_uni\_grad* = *max\_output* \* *non\_uni\_grad\_efficiency*  
*unit\_output\_uni\_grad* = *max\_output* \* *uni\_grad\_efficiency*  
*uni\_grad\_efficiency* = (*norm\_other\_sec\_inv\_all\_workers* +  
*tech\_indicator* + *std\_edu\_quality\_factor\_uni*)/3  
*uni\_grad\_job\_ratio* = 0.12  
*Uni\\_non\_uni* = 16/8

*edu\_quality\_factor\_CoHE* =

*GRAPH(acd\_teacher\_per\_student\_CoHE \* edu\_inv\_per\_student\_CoHE)*

(0.00, 0.00), (107, 0.1), (213, 0.195), (320, 0.3), (427, 0.4), (533, 0.505),  
(640, 0.61), (747, 0.685), (853, 0.78), (960, 0.895), (1066, 1.00)

*edu\_quality\_factor\_MoE* =

*GRAPH(edu\_inv\_per\_student\_MoE \* teacher\_per\_student\_MoE)*

(0.00, 0.00), (296, 0.15), (593, 0.29), (889, 0.385), (1185, 0.455), (1482, 0.575),  
(1778, 0.68), (2075, 0.77), (2371, 0.865), (2667, 1.00)

*patent\_per\_1000\_population* = *GRAPH(inv\_researcher)*

(0.00, 0.00), (29992, 0.0238), (59984, 0.037), (89977, 0.0502), (119969, 0.07),  
(149961, 0.0924), (179953, 0.11), (209946, 0.14), (239938, 0.177), (269930, 0.21),  
(299922, 0.264)

*teacher\_grad\_rate* =

*GRAPH(educational\_investment\_MoE / INIT(educational\_investment\_MoE))*

(0.00, 0.00), (0.5, 0.052), (1.00, 0.108), (1.50, 0.144), (2.00, 0.178),  
(2.50, 0.21), (3.00, 0.252), (3.50, 0.3), (4.00, 0.346), (4.50, 0.384), (5.00, 0.4)

## **Appendix C**

### **SENSITIVITY ANALYSIS**

The limits of the sensitivity analysis ranges are designated to be within  $\pm 0.25$  times the current values of the allowable parameters themselves. Within the given range, 20 runs are conducted equally incrementally. Indicators are selected to be GDP, GDP per capita, and Total unemployment.

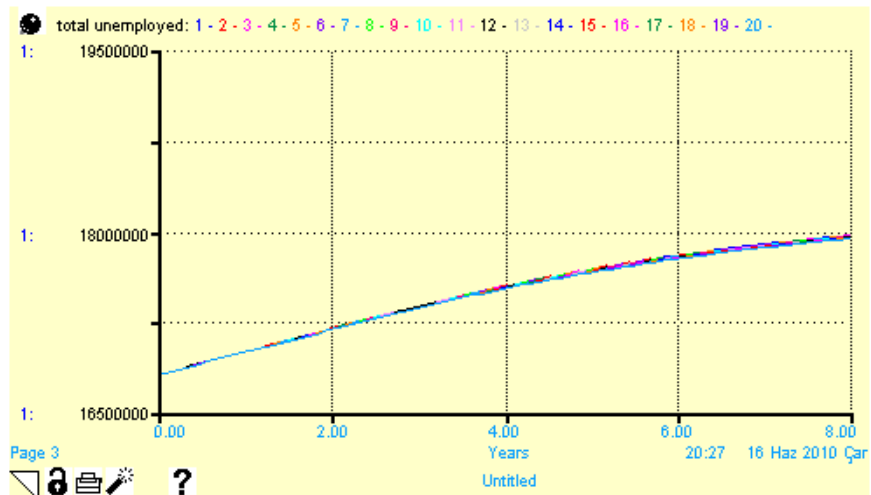
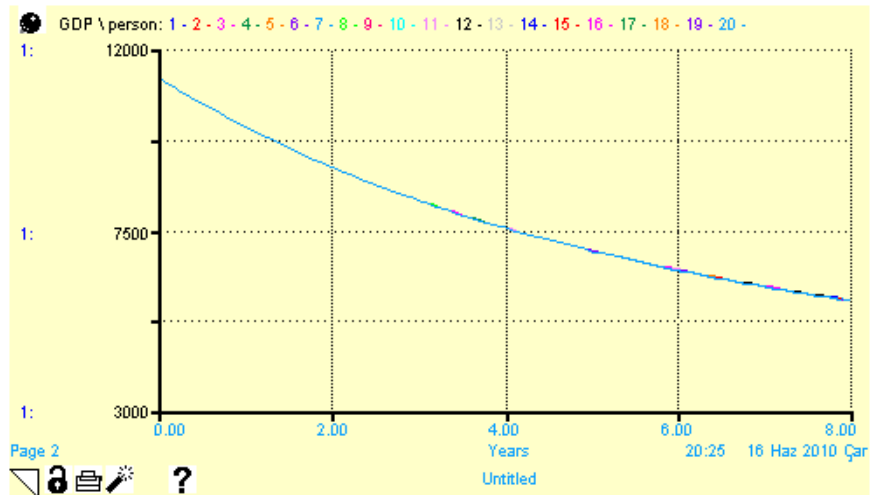
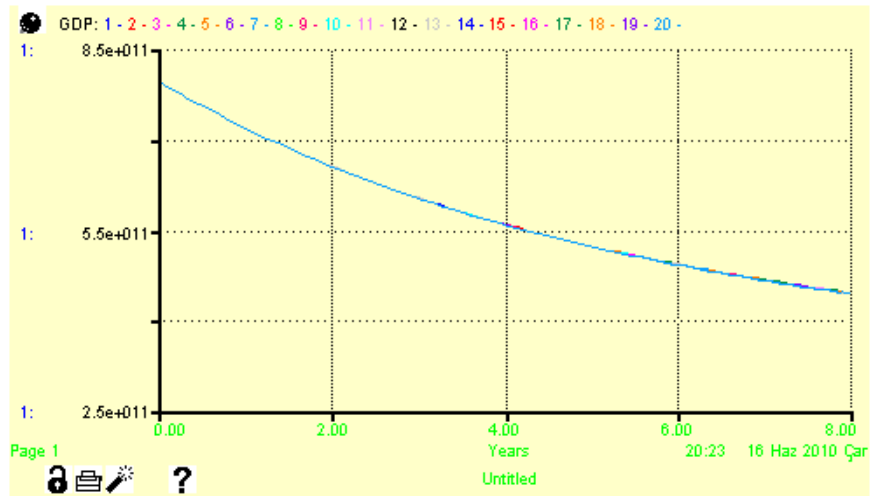

Figure C.1: Sensitivity of Grad\_school\_enrollment. Range:[15000-25000]

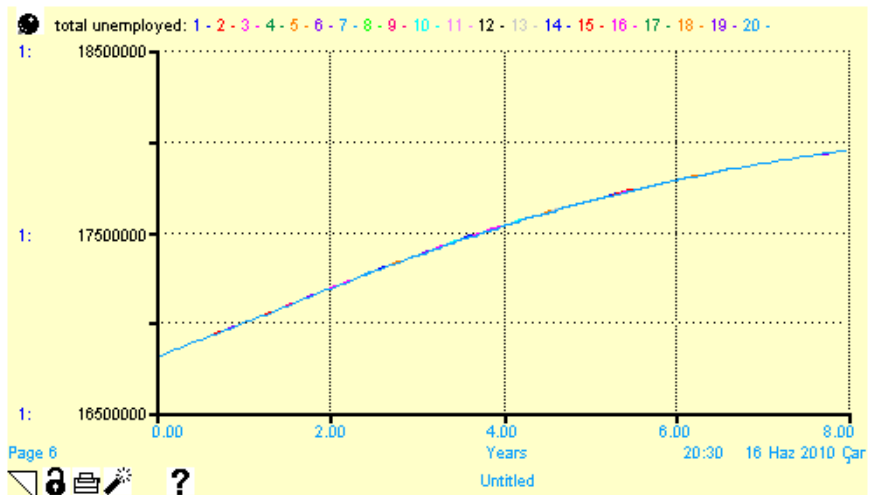
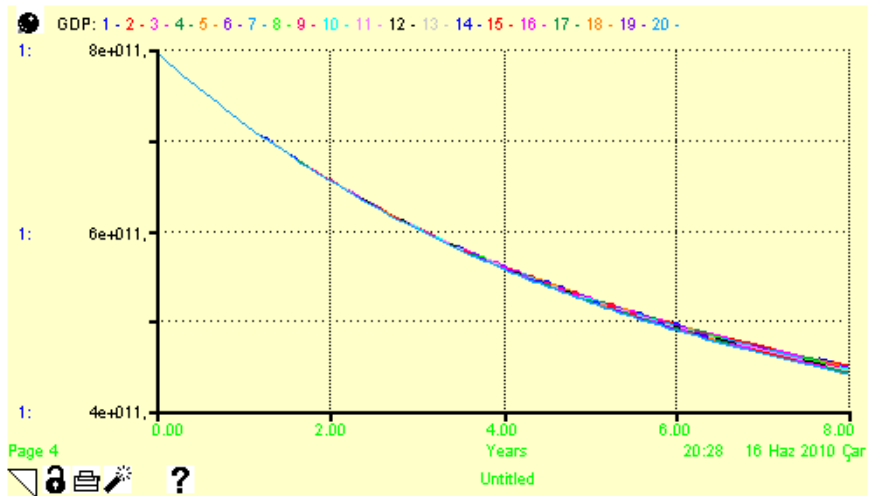

Figure C.2: Sensitivity of new academicians. Range:[3000-5000]

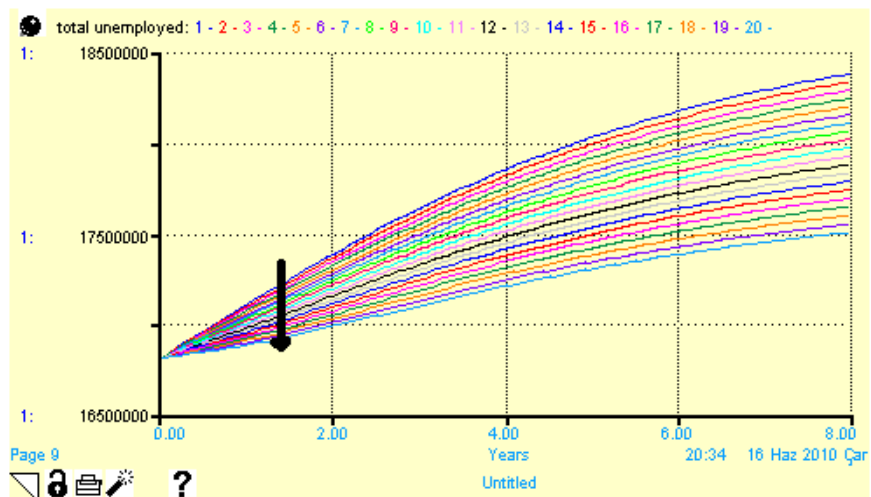
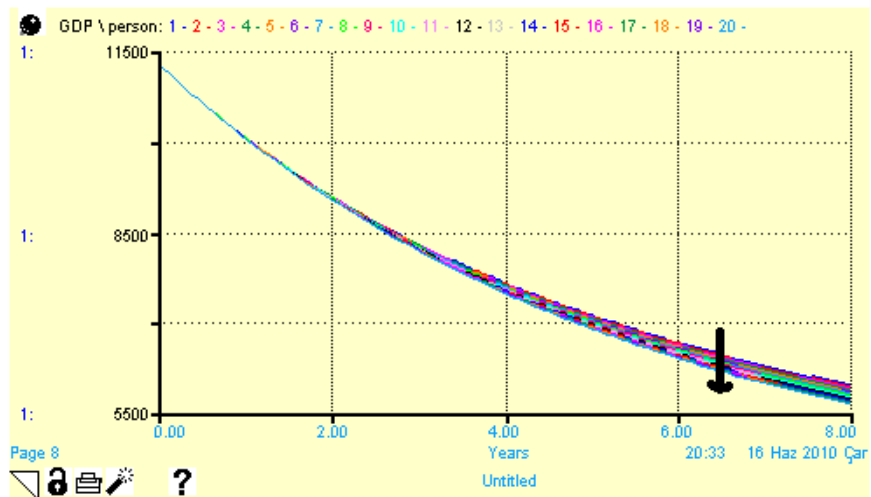
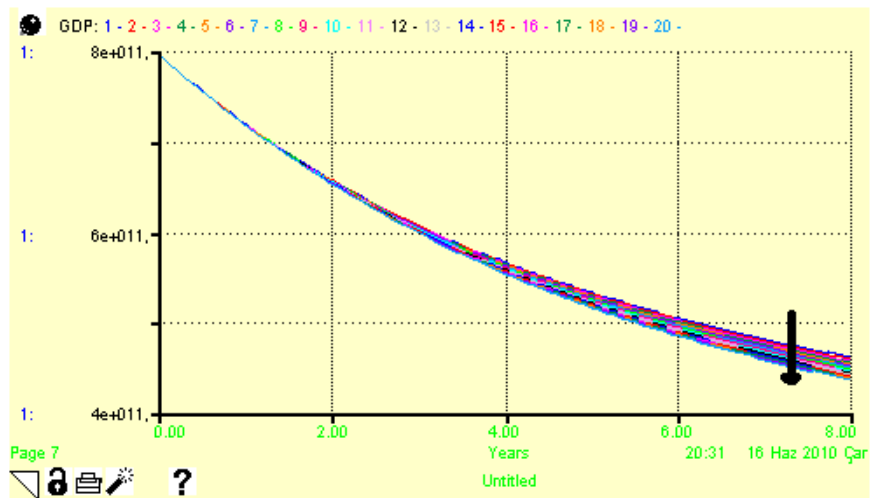

Figure C.3: Sensitivity of university\_enrollment. Range:[375000-625000]

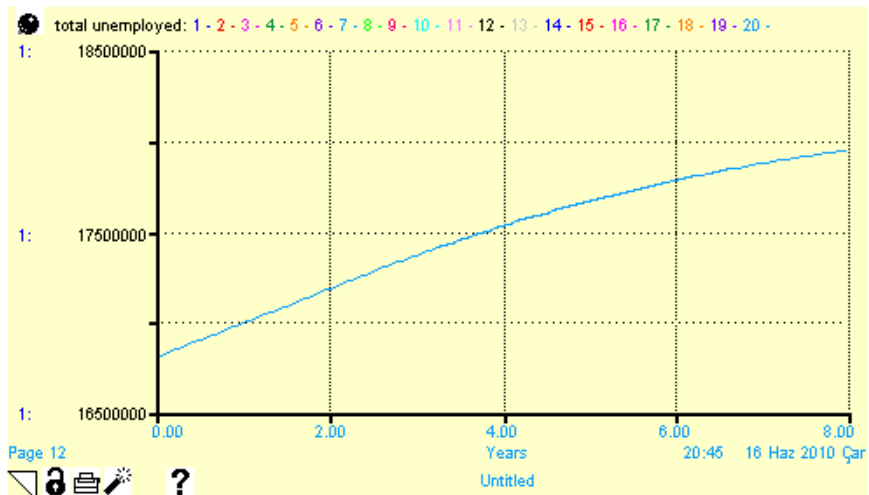
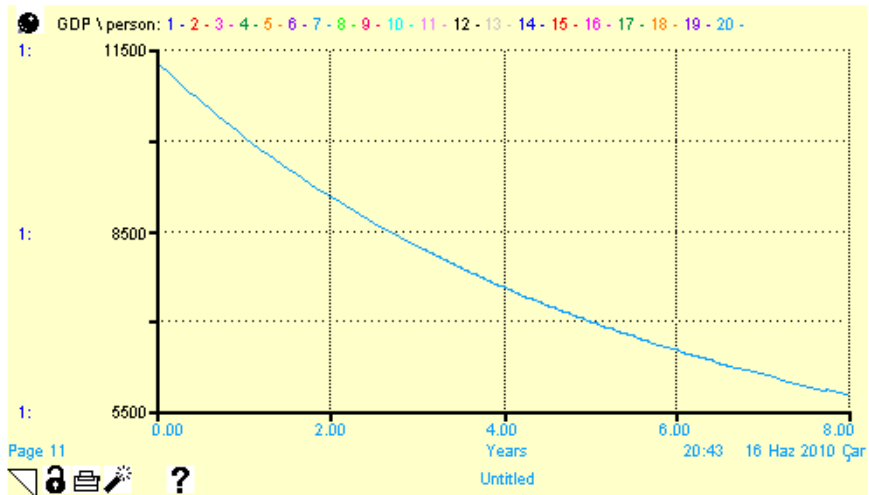
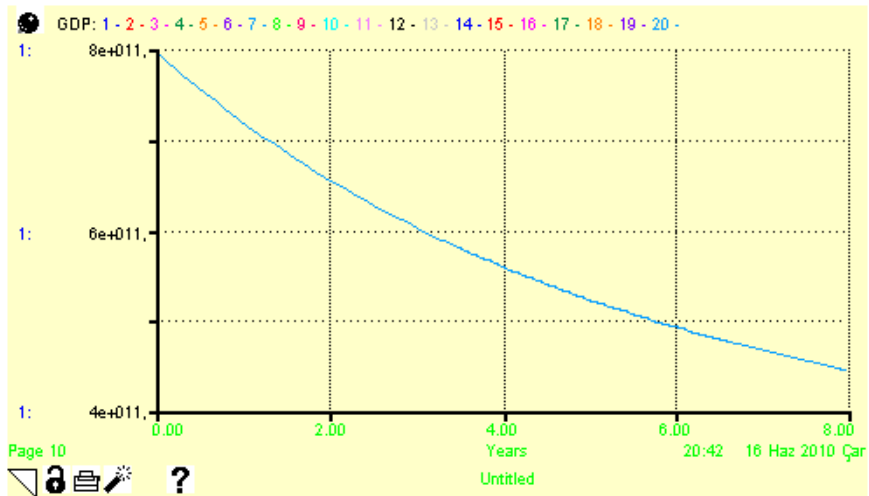

Figure C.4: Sensitivity of acad\_res\_inv\_ratio. Range:[0.332-0.552]

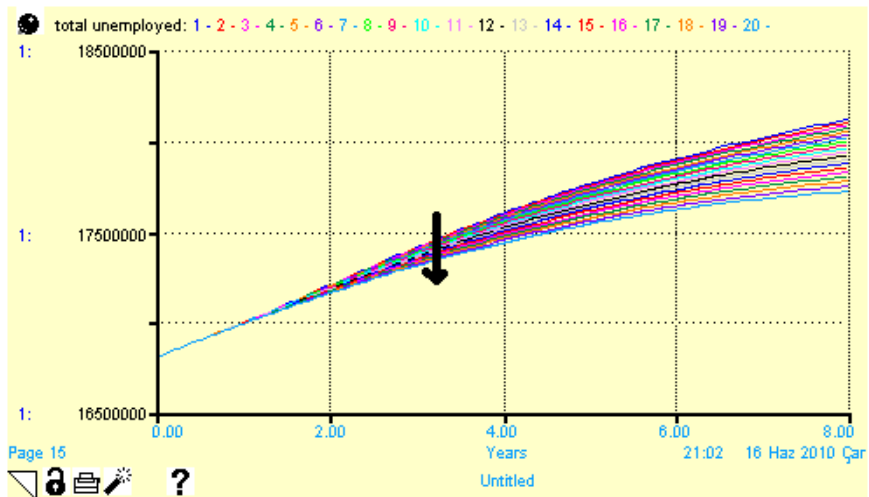
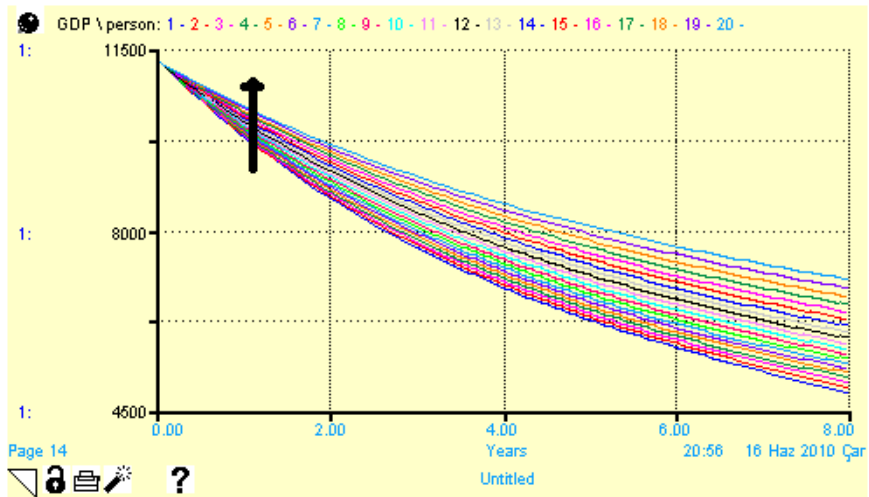
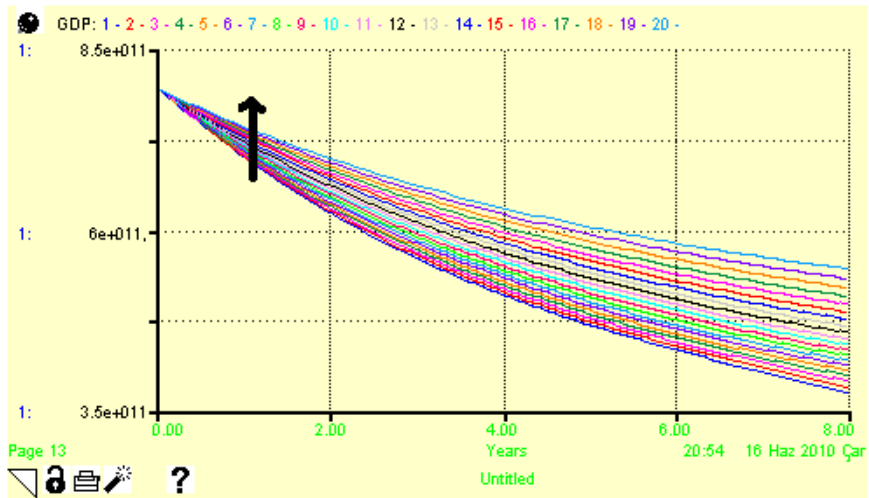

Figure C.5: Sensitivity of acd\_tea\_factor. Range:[0.45-0.75]



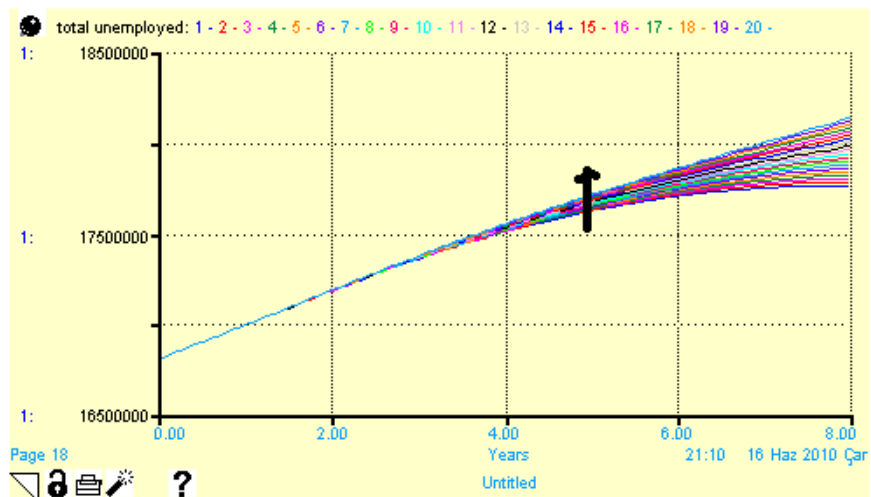
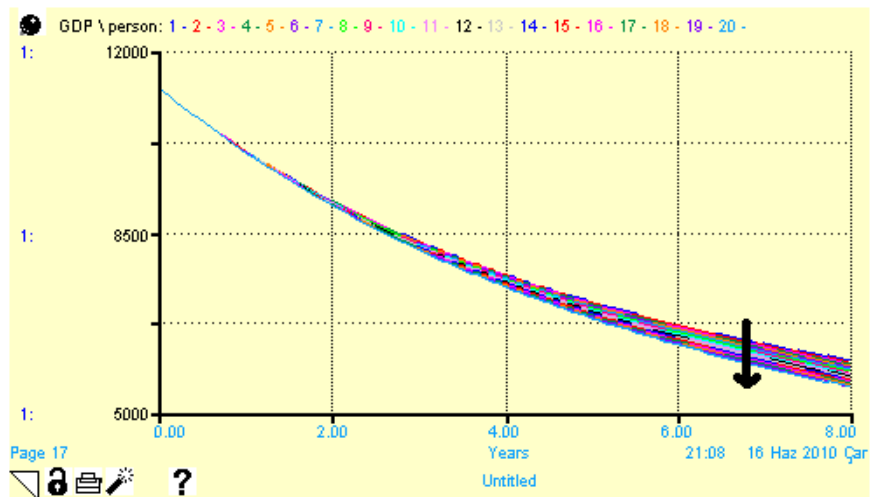
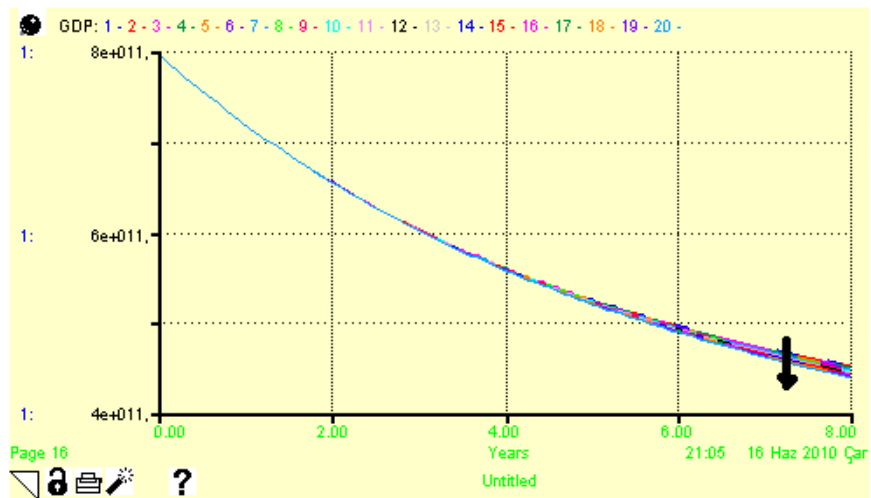

Figure C.6: Sensitivity of birth\_rate. Range:[0.014-0.0234]

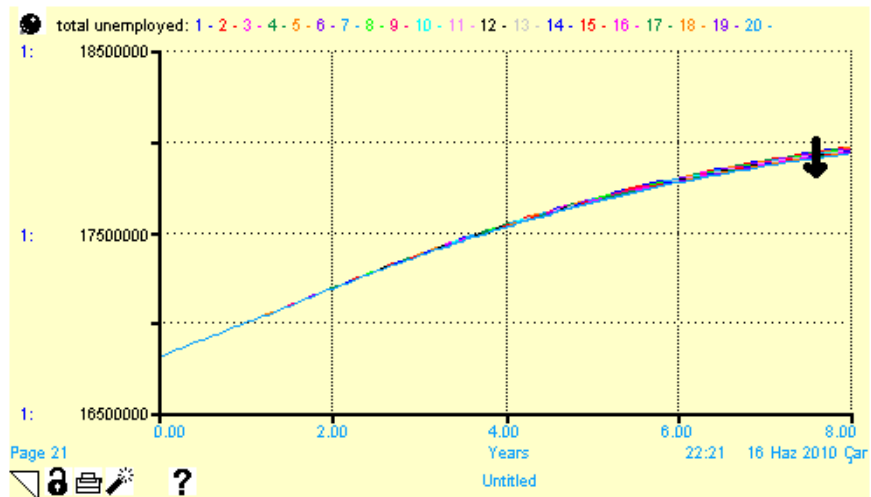
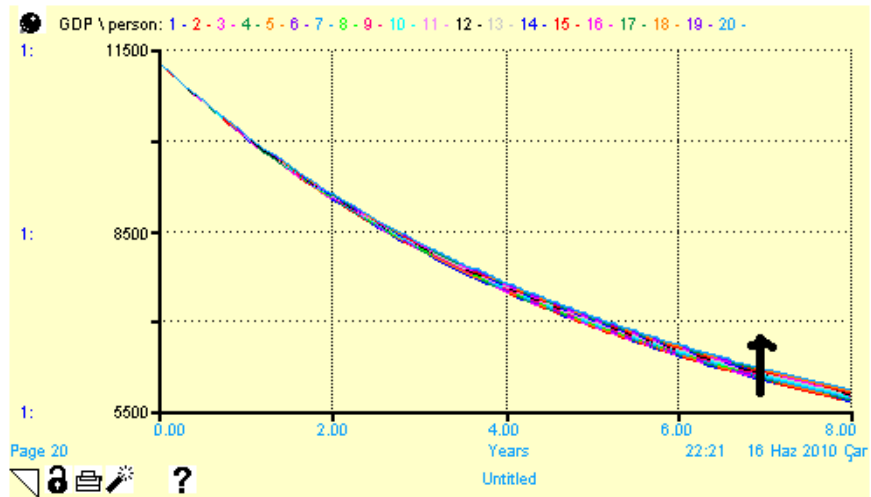
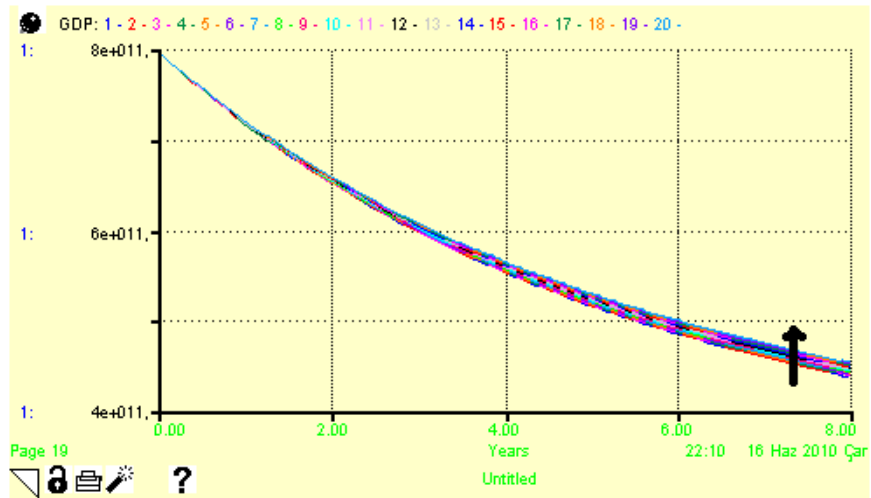

Figure C.7: Sensitivity of Edu\_inv\_CoHE\_ratio. Range:[0.0075-0.0125]

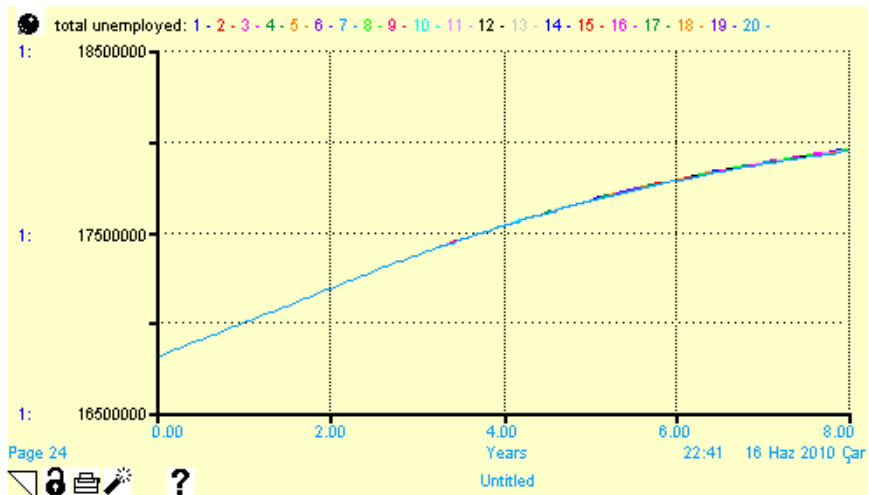
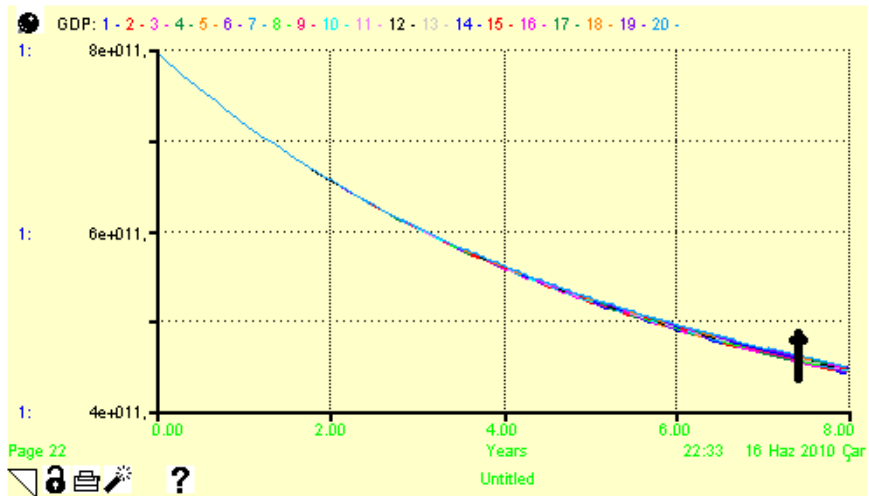

Figure C.8: Sensitivity of Edu\_inv\_MoE\_ratio. Range:[0.03-0.05]

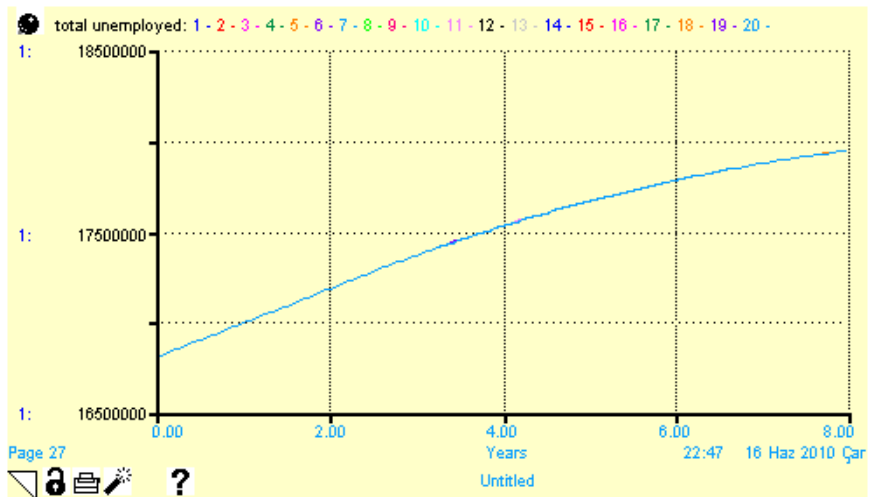
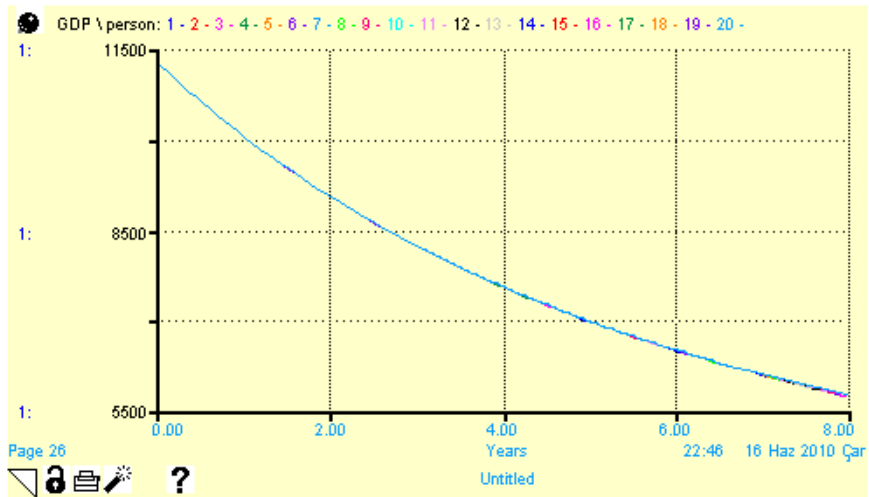
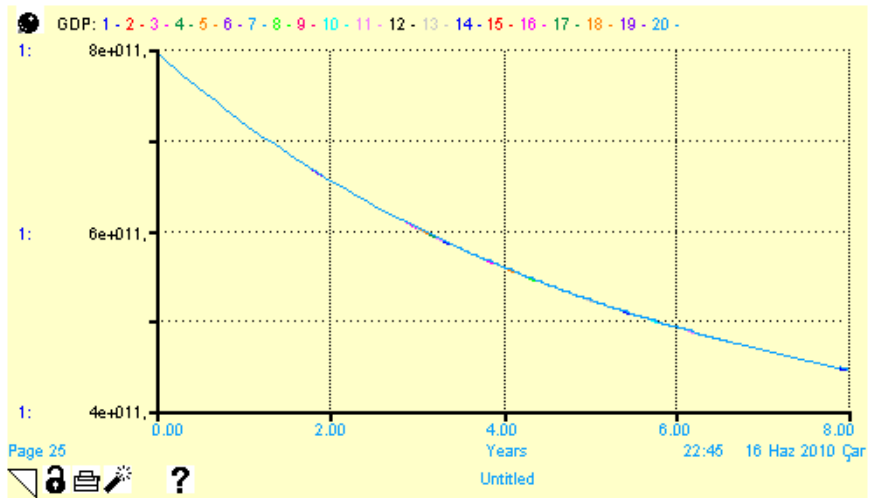

Figure C.9: Sensitivity of Grad\_school\_grad\_job\_ratio. Range:[0.0225-0.0375]

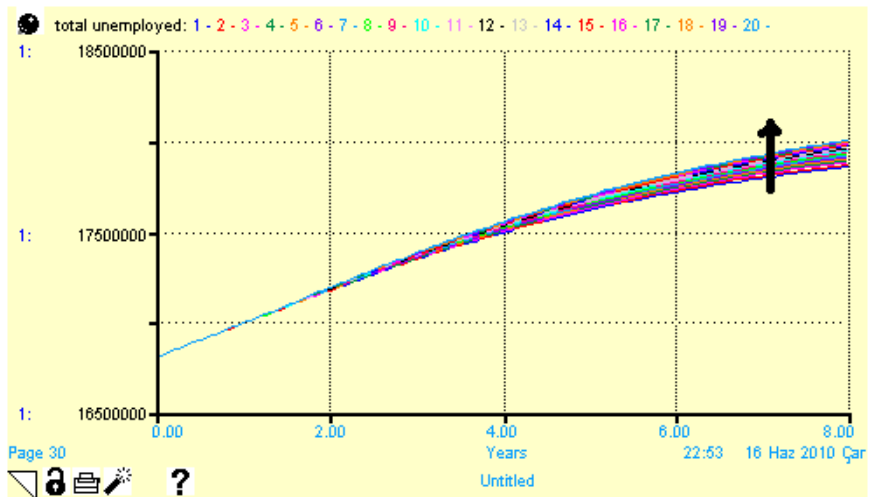
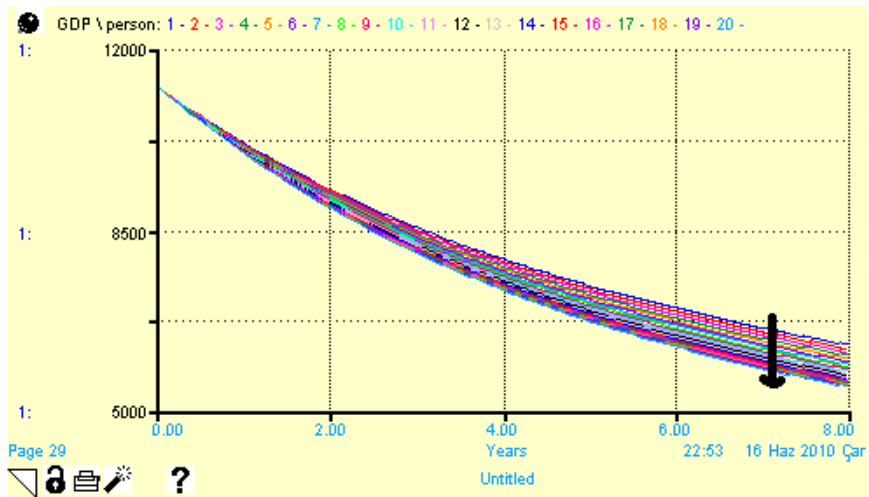
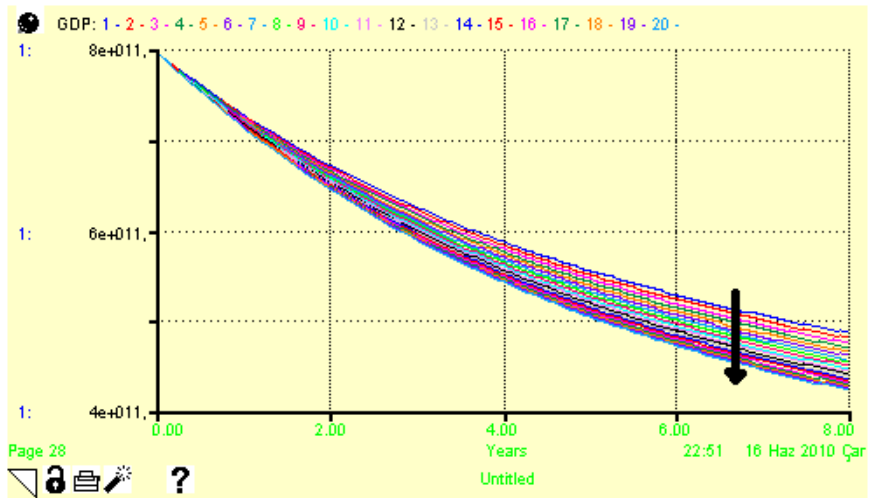

Figure C.10: Sensitivity of Grad/uni. Range:[0.892- 1.49]

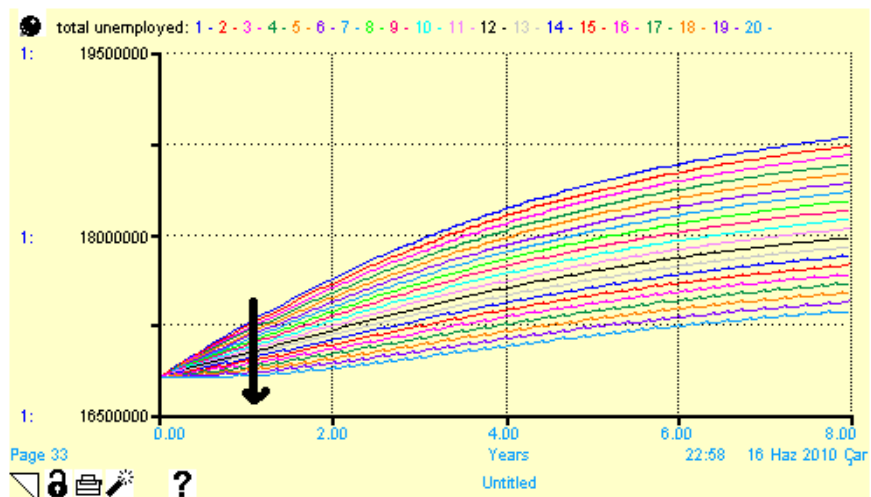
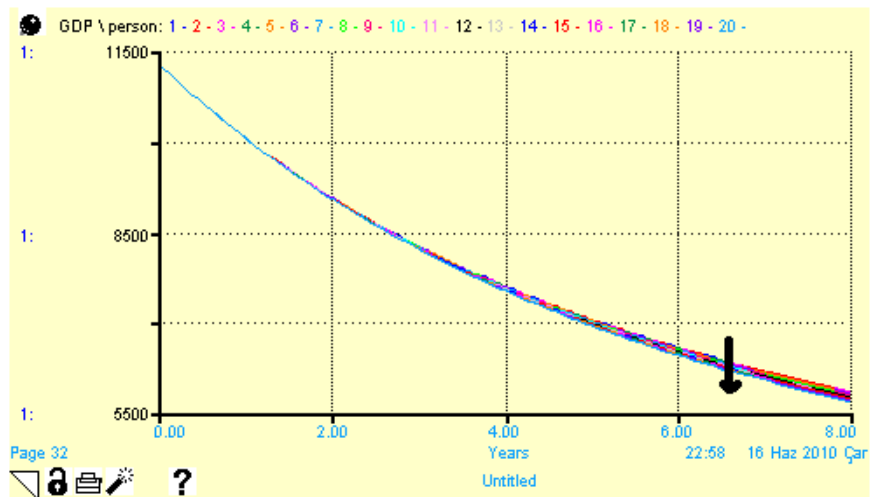
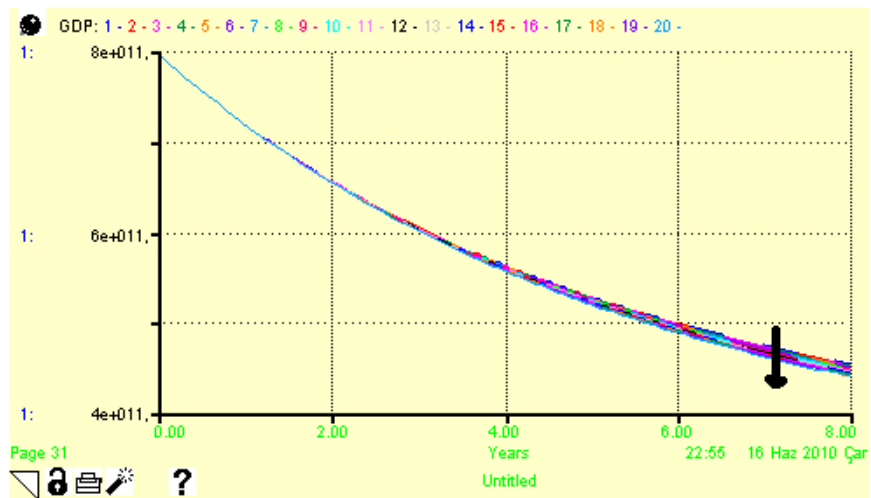

Figure C.11: Sensitivity of High\_school\_enrollment\_factor. Range:[0.637-1]

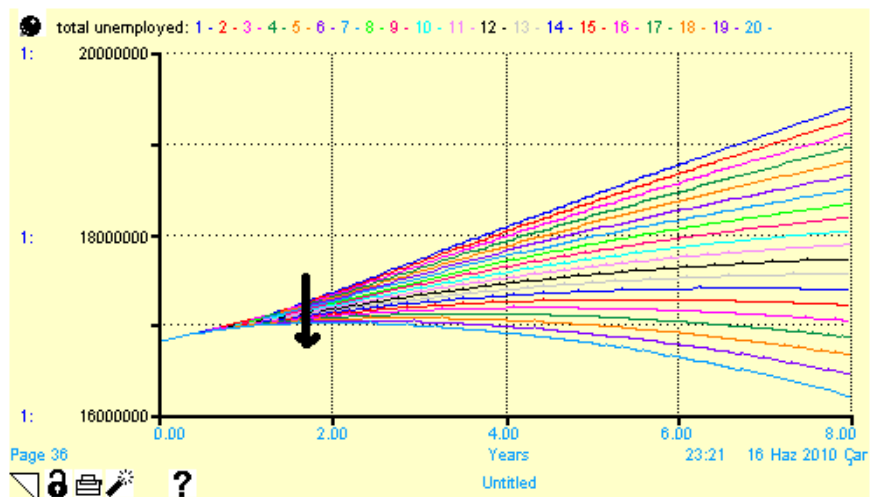
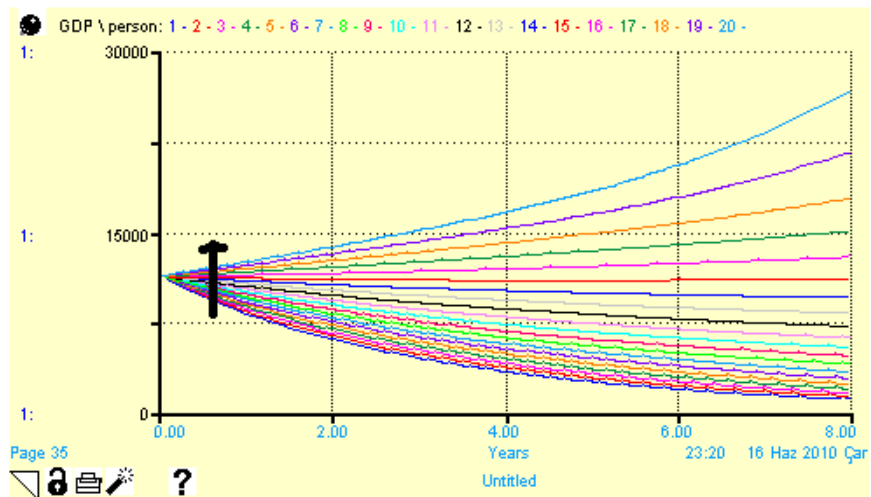
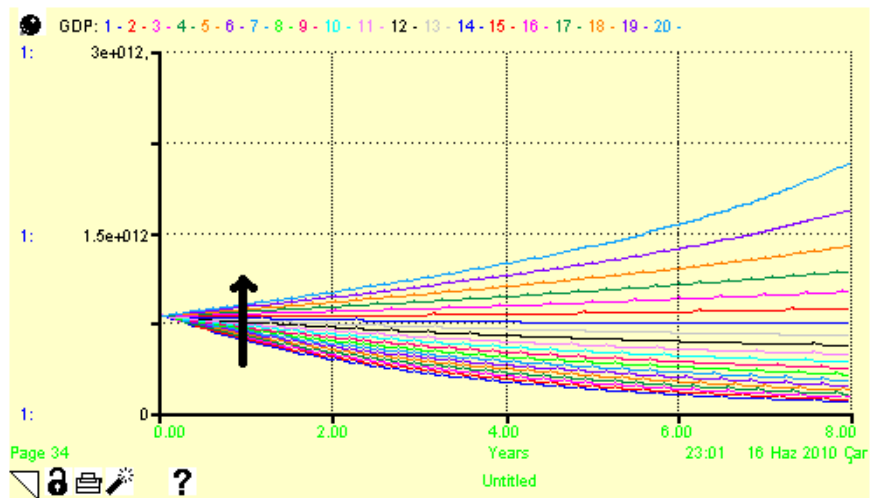

Figure C.12: Sensitivity of Max output. Range:[131250-218750]

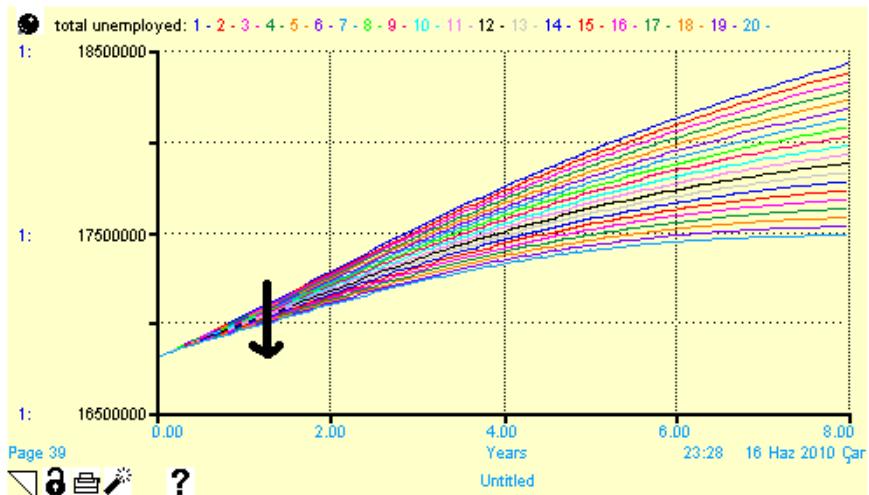
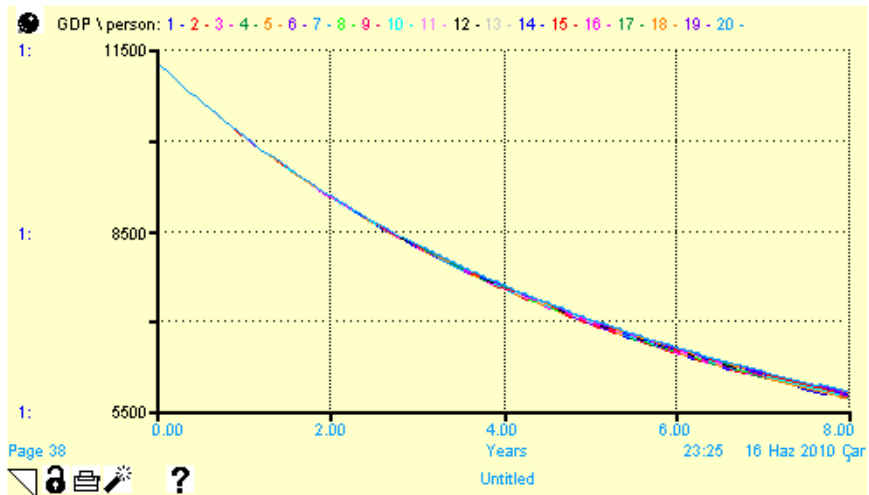
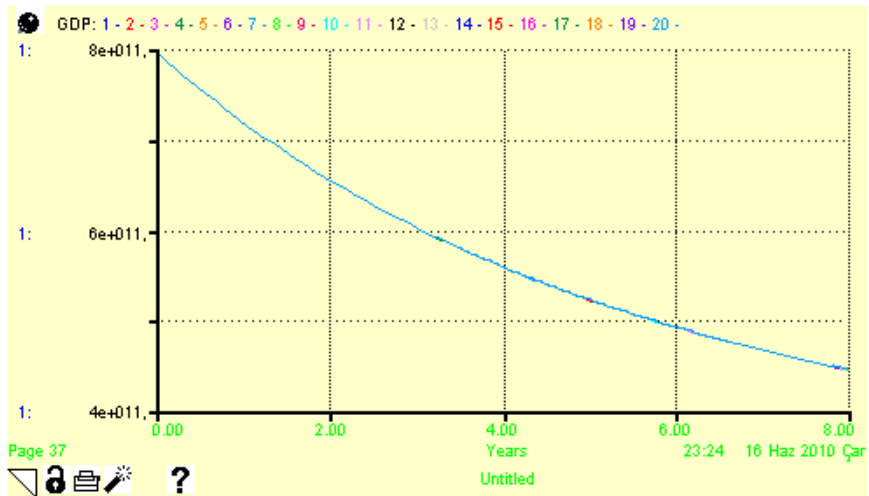

Figure C.13: Sensitivity of Mortality. Range:[0.00443-0.00737]



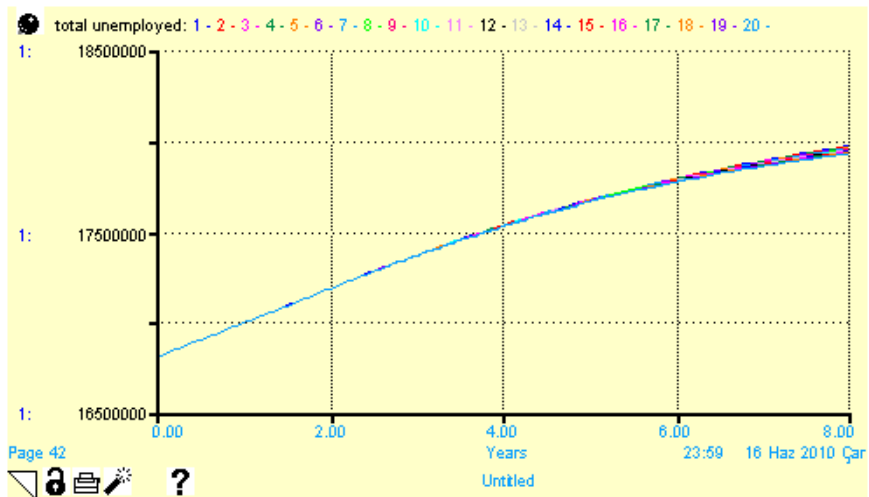
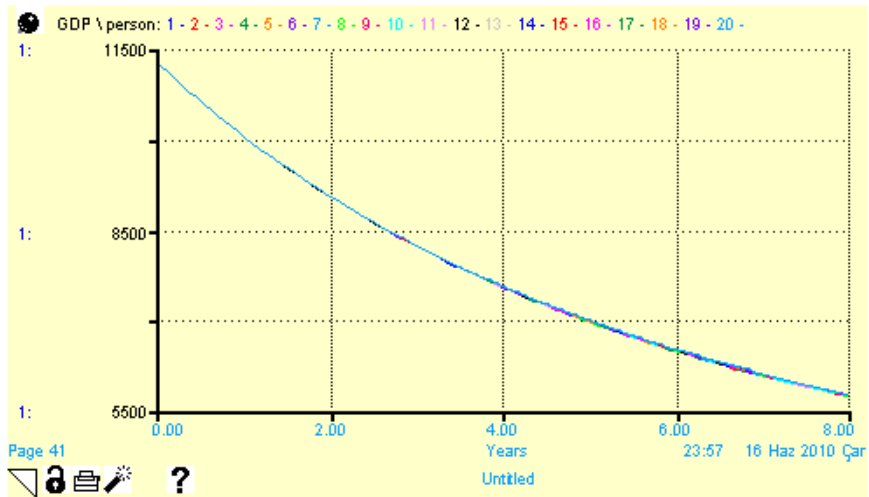
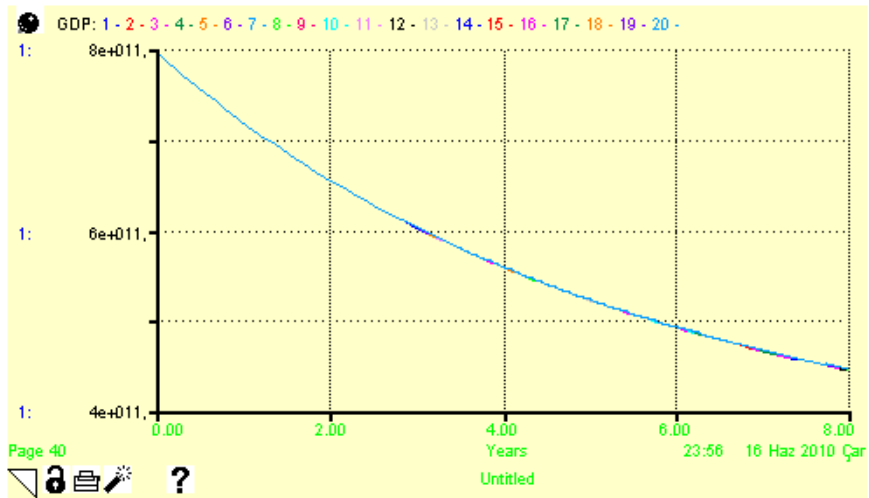

Figure C.14: Sensitivity of Mortal\_0\_to\_5. Range:[0.0165-0.0275]

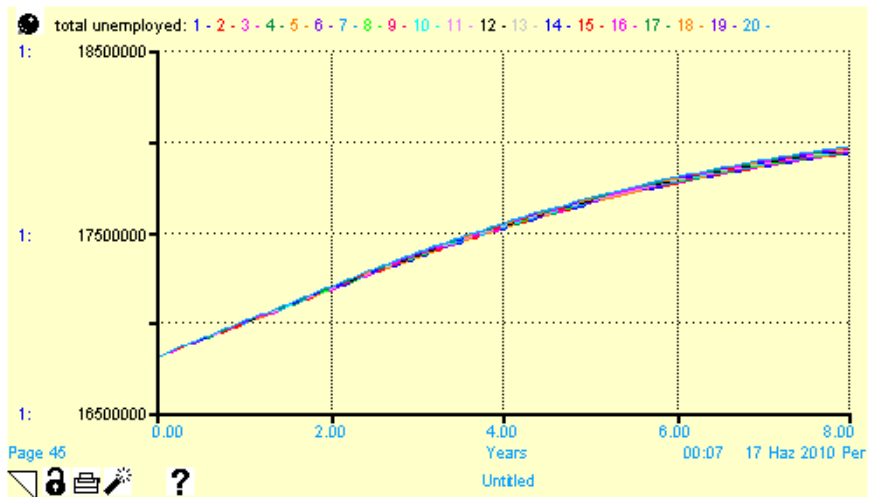
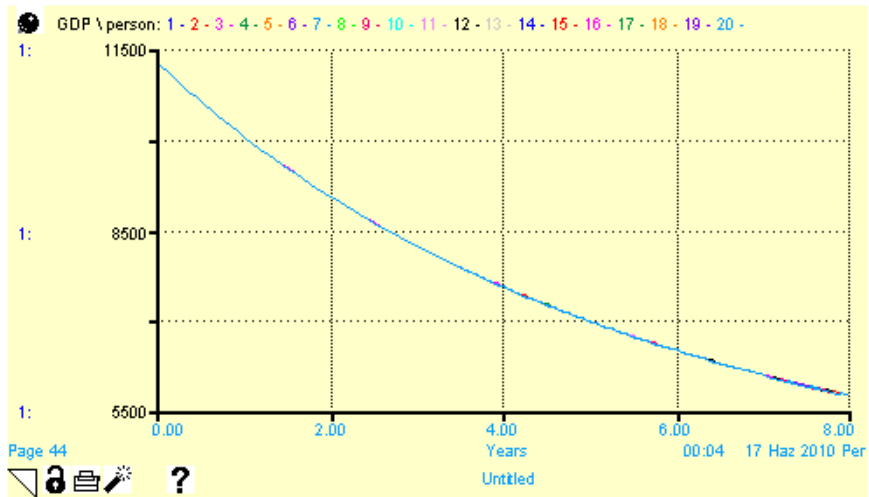
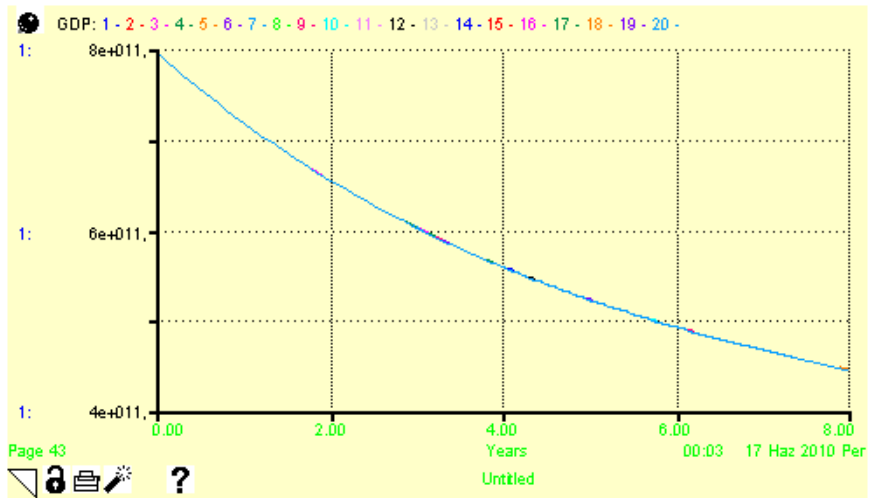

Figure C.15: Sensitivity of Quit\_or\_dismissal\_rate. Range:[0.0015-0.0025]

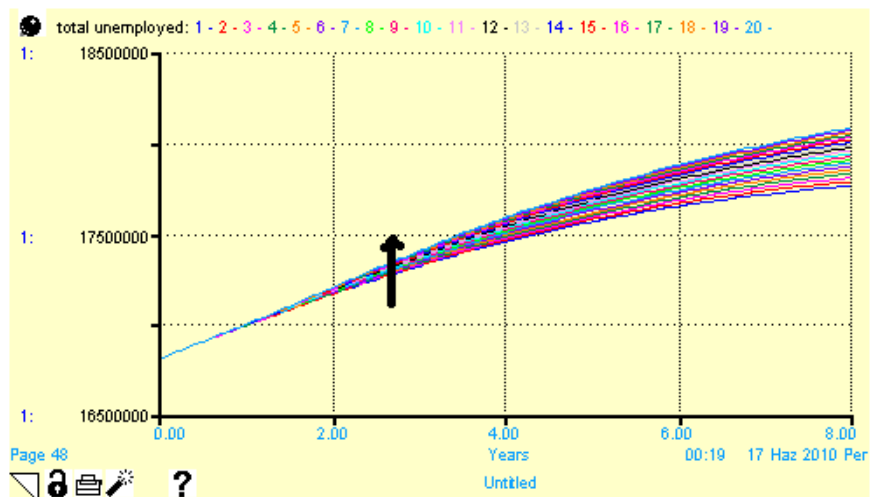
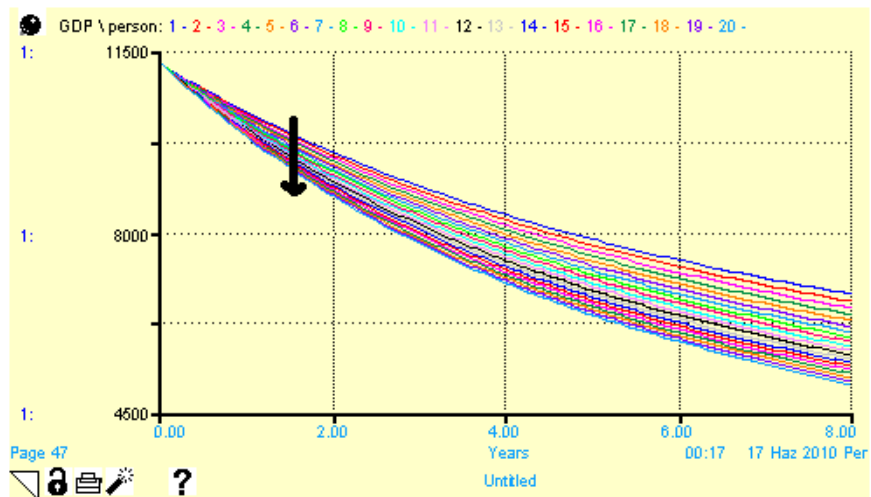
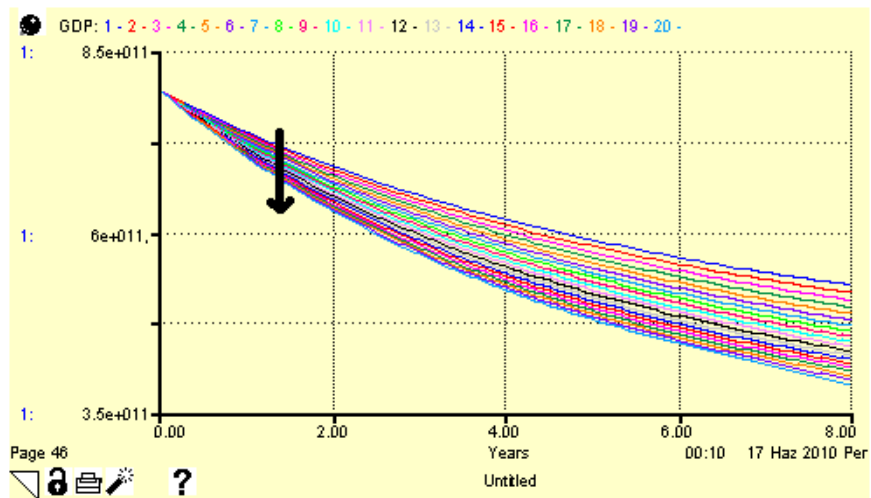

Figure C.16: Sensitivity of researcher\_worker\_ratio. Range:[0.00187-0.00313]

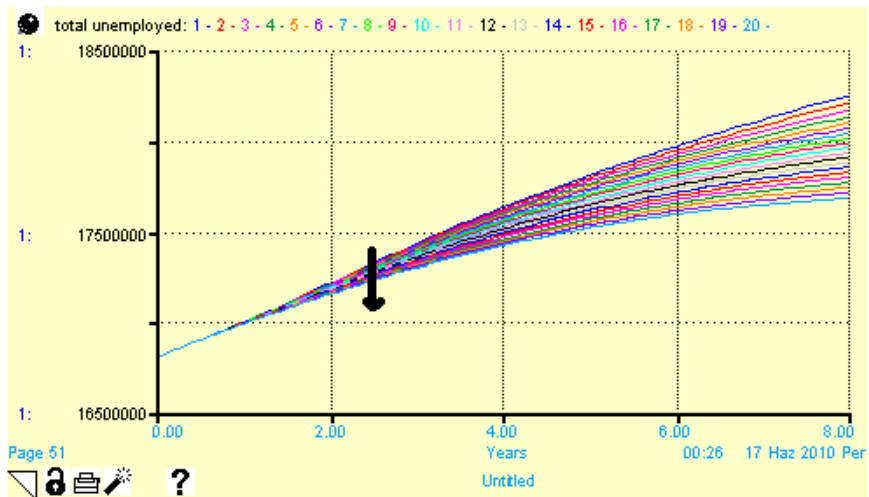
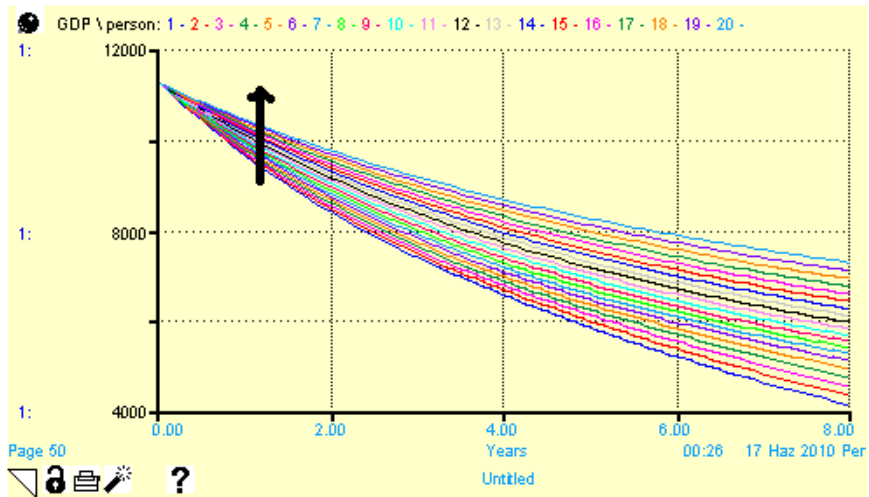
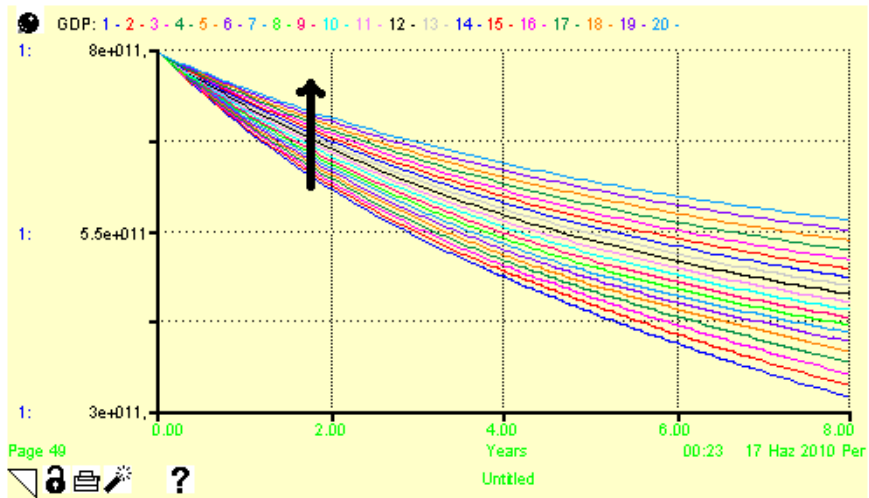

Figure C.17: Sensitivity of Research\_inv\_ratio. Range:[0.00547-0.00912]

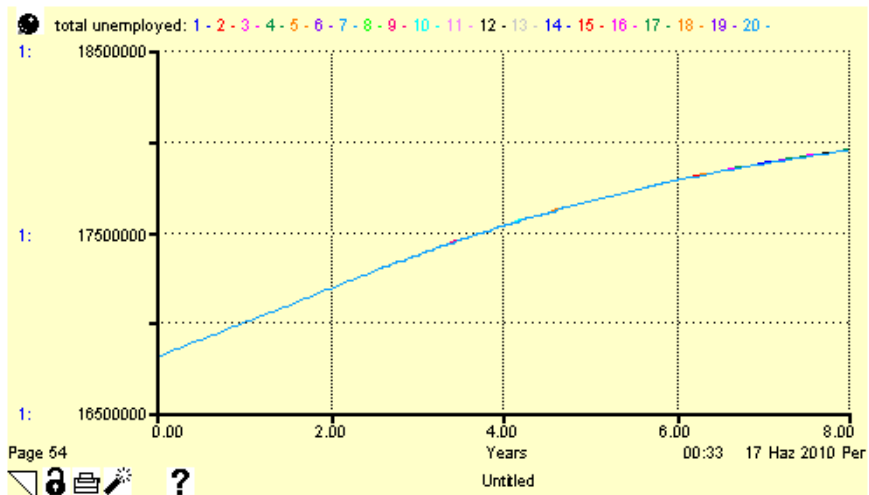
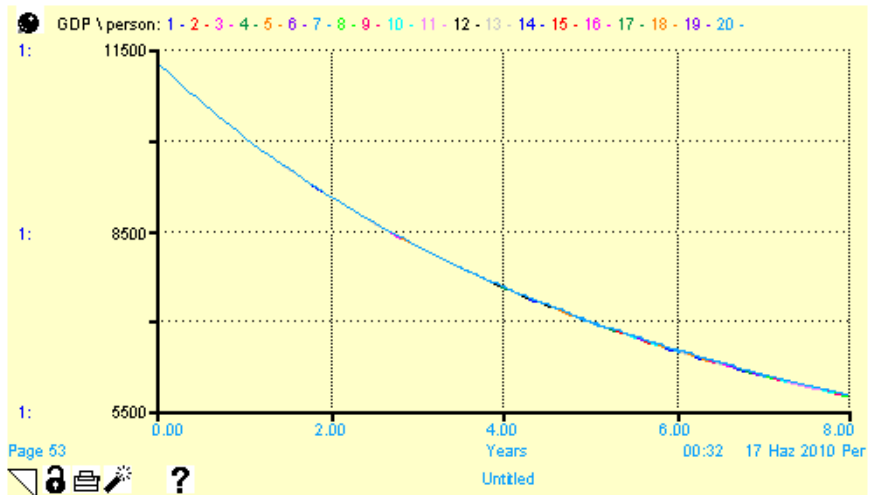
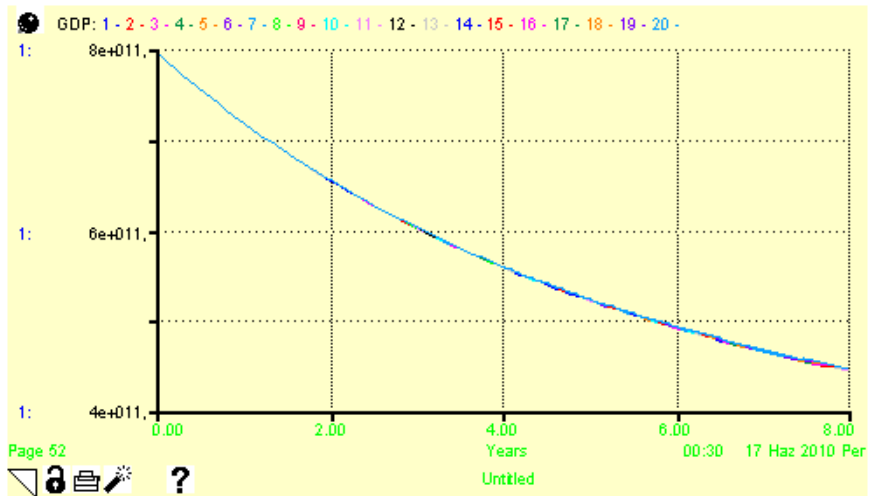

Figure C.18: Sensitivity of Uni\_grad\_job\_ratio. Range:[0.09-0.15]

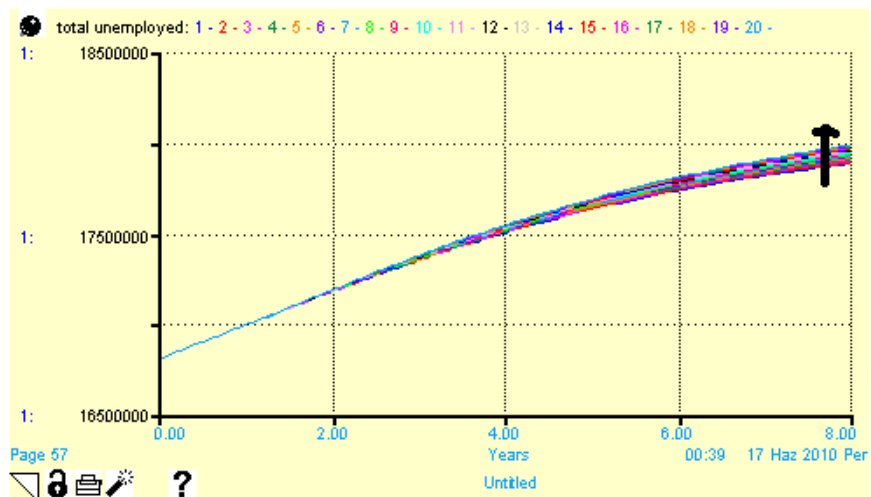
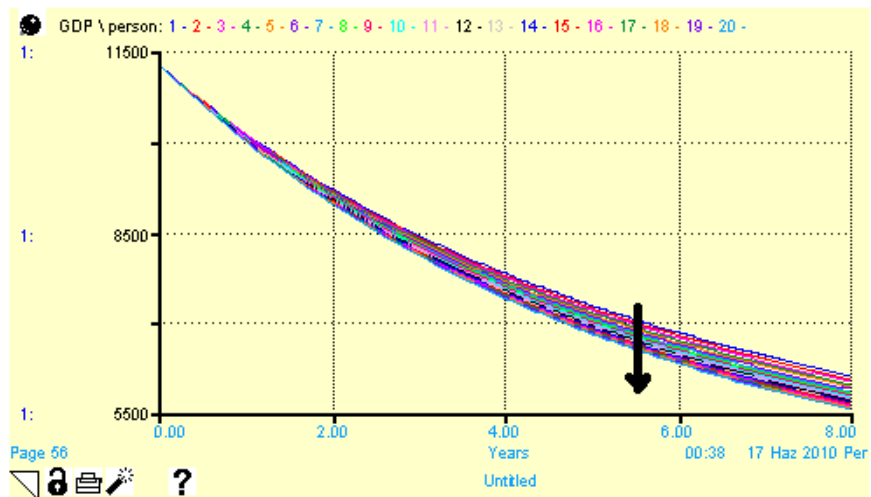
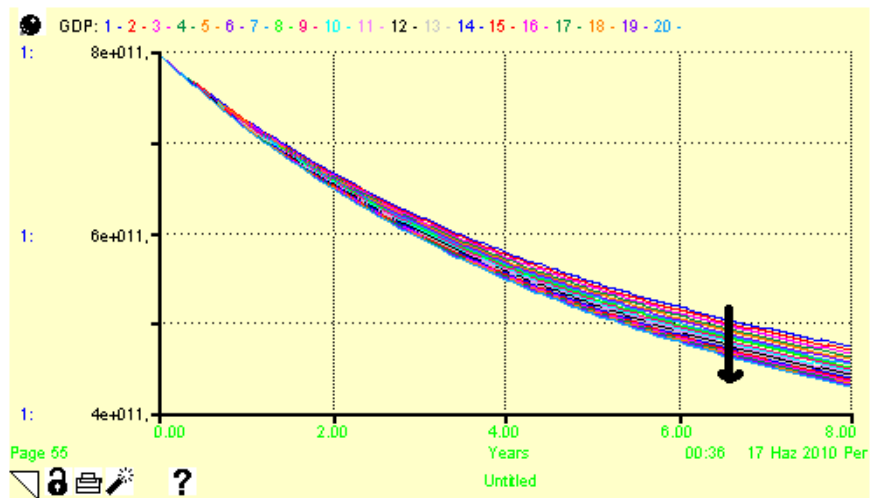

Figure C.19: Sensitivity of Uni.\\_non\_uni. Range:[1.5-2.5]

## Appendix D

### EXTREME CONDITIONS TEST

#### 1. Grad\_school\_enrollment

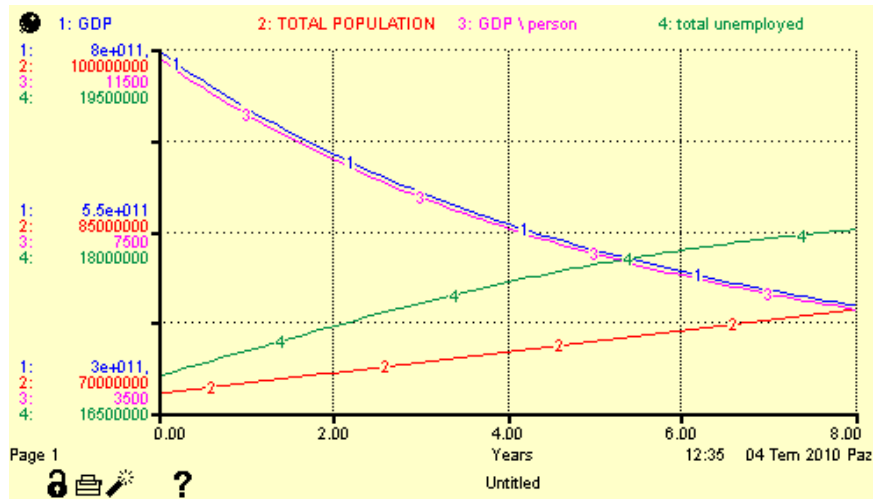

Figure D.1: Extreme Conditions Test Results for grad\_school\_enrollment. Min = 0

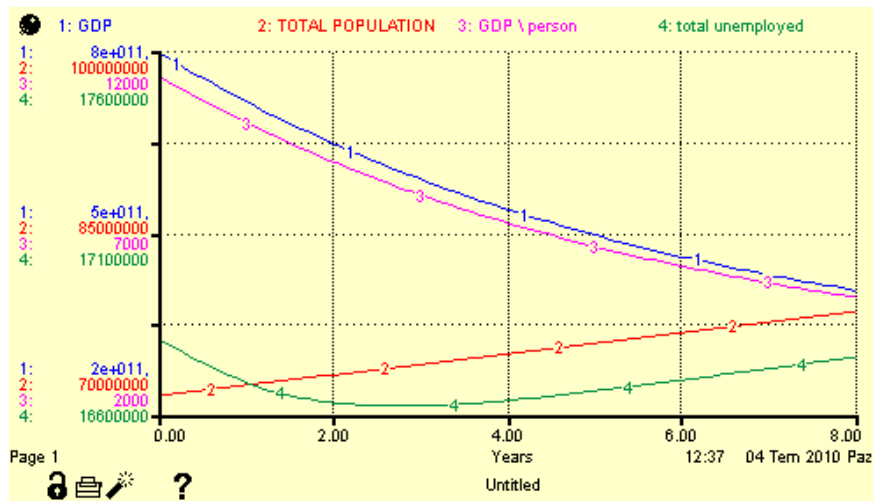

Figure D.2: Extreme Conditions Test Results for grad\_school\_enrollment. Min = 400000



## 2. New\_academicians



Figure D.3: Extreme Conditions Test Results for new\_academicians. Min = 0

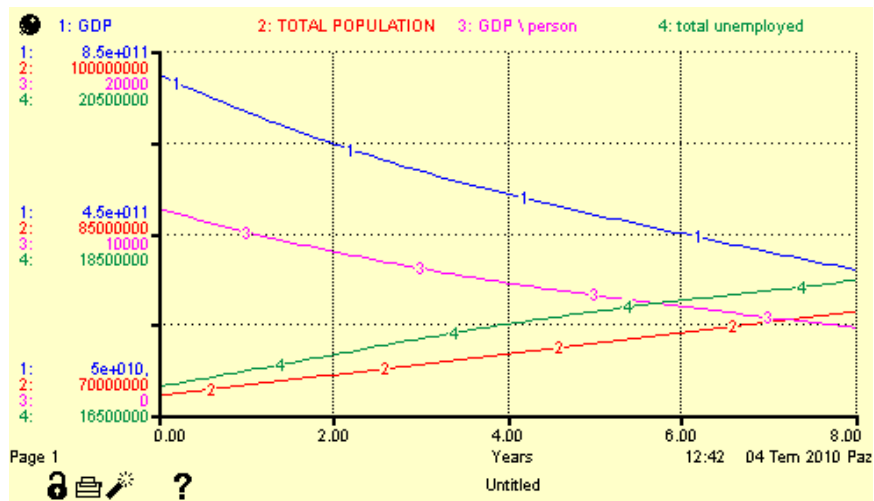

Figure D.4: Extreme Conditions Test Results for new\_academicians. Max = 20000

### 3. University\_enrollment

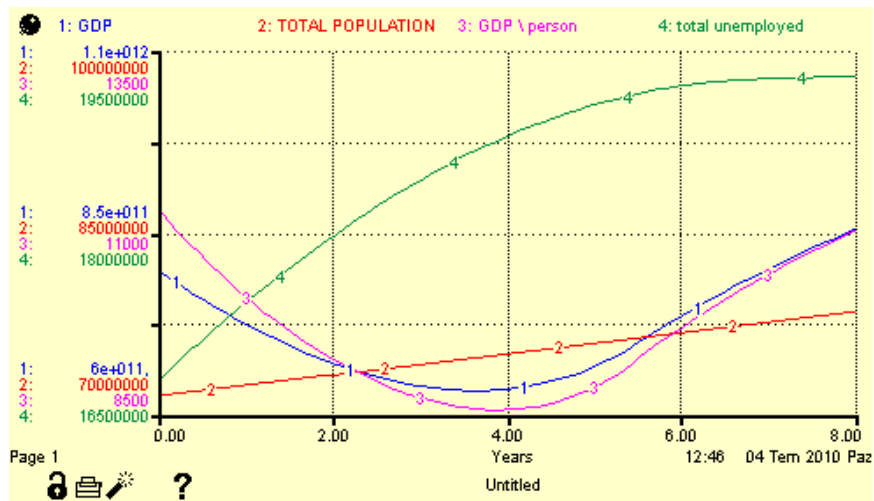

Figure D.5: Extreme Conditions Test Results for university\_enrollment. Min = 0

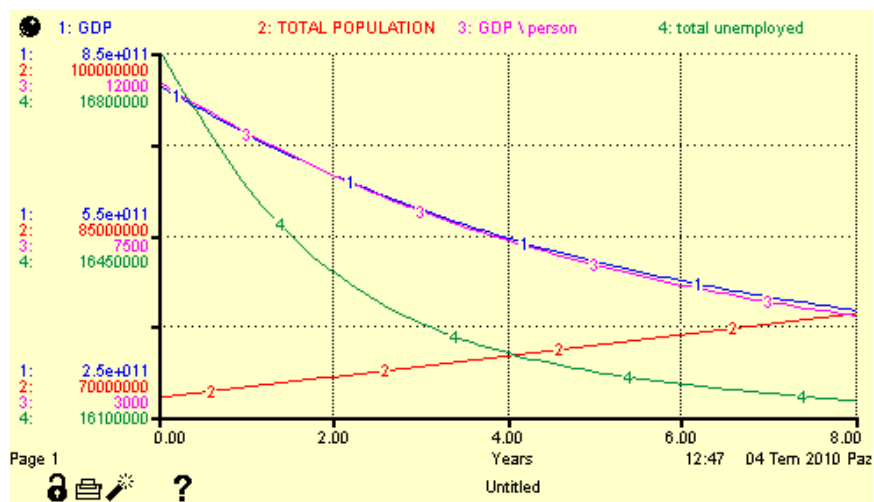

Figure D.6: Extreme Conditions Test Results for university\_enrollment. Max=1000000

4. Acd\_tea\_factor



Figure D.7: Extreme Conditions Test Results for acd\_tea\_factor. Min = 0

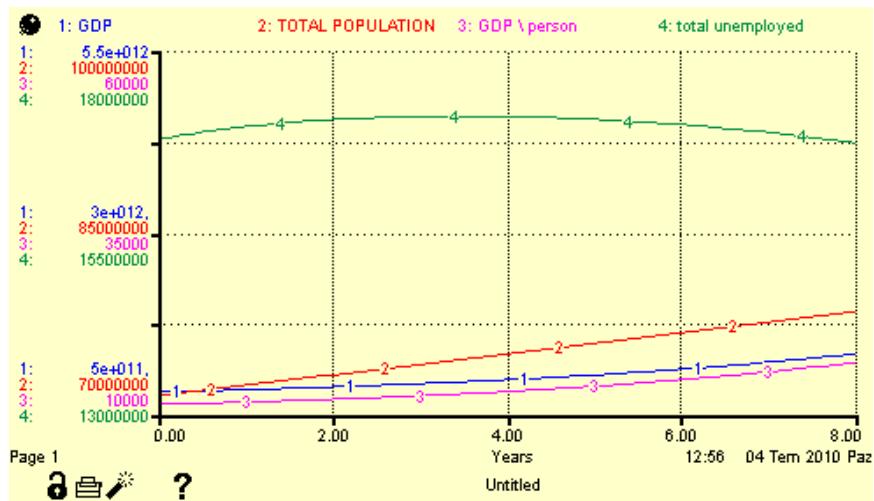

Figure D.8: Extreme Conditions Test Results for acd\_tea\_factor. Max = 1

5. Birth\_rate

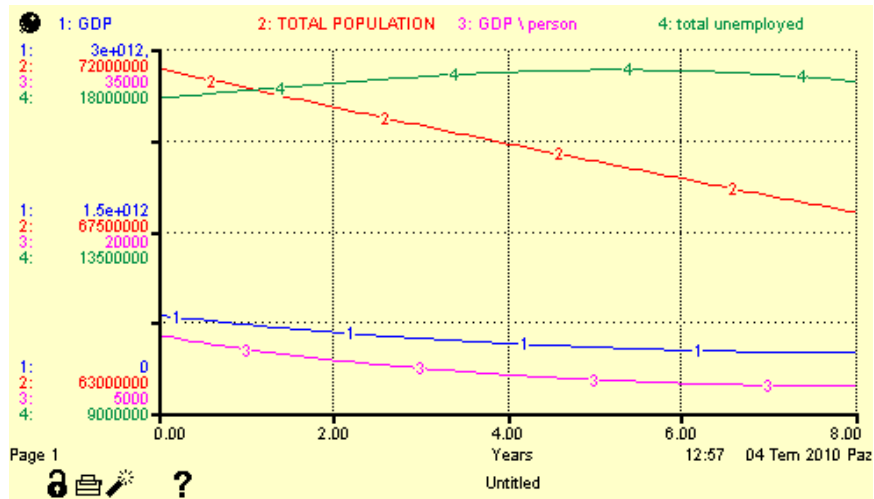

Figure D.9: Extreme Conditions Test Results for birth\_rate. Min = 0

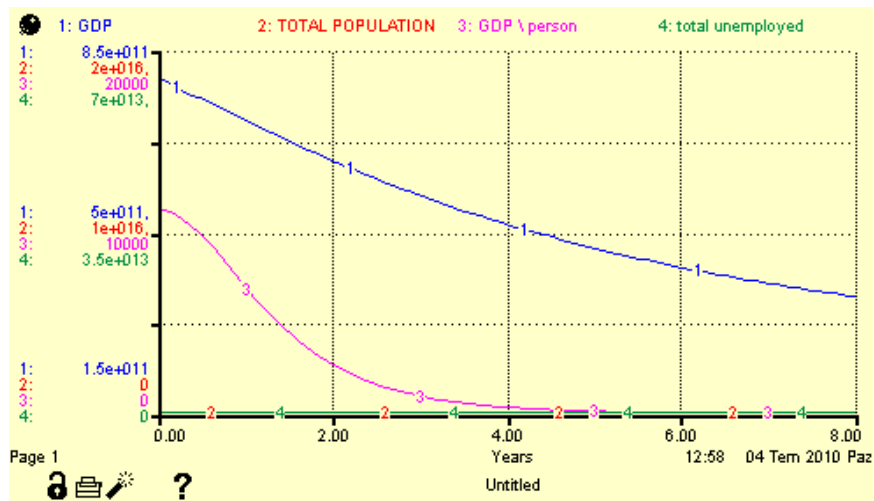

Figure D.10: Extreme Conditions Test Results for birth\_rate. Max = 1

6. High\_school\_enrollment\_factor

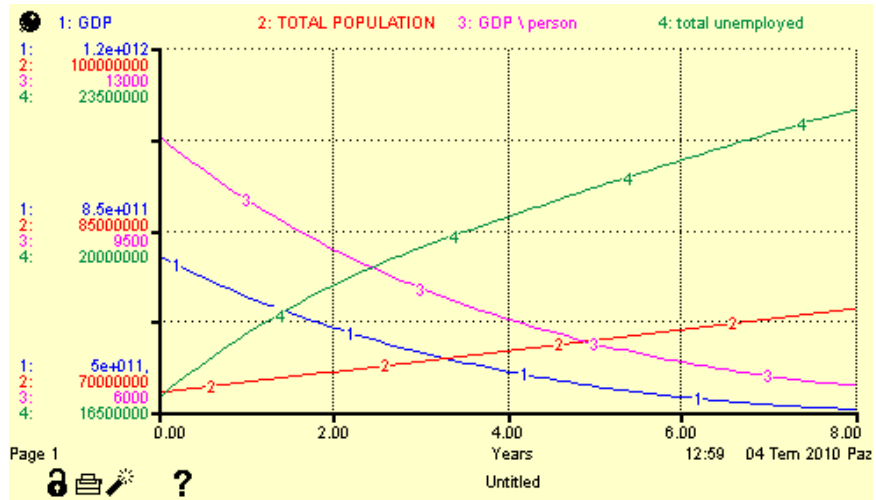

Figure D.11: Extreme Conditions Test Results for high\_school\_enrollment\_factor. Min = 0

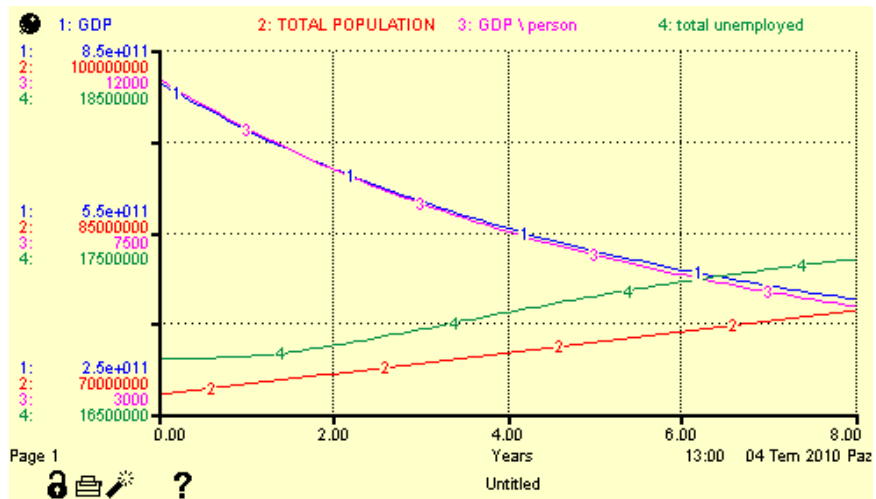

Figure D.12: Extreme Conditions Test Results for high\_school\_enrollment\_factor. Max = 1

## 7. Mortality



Figure D.13: Extreme Conditions Test Results for mortality. Min = 0

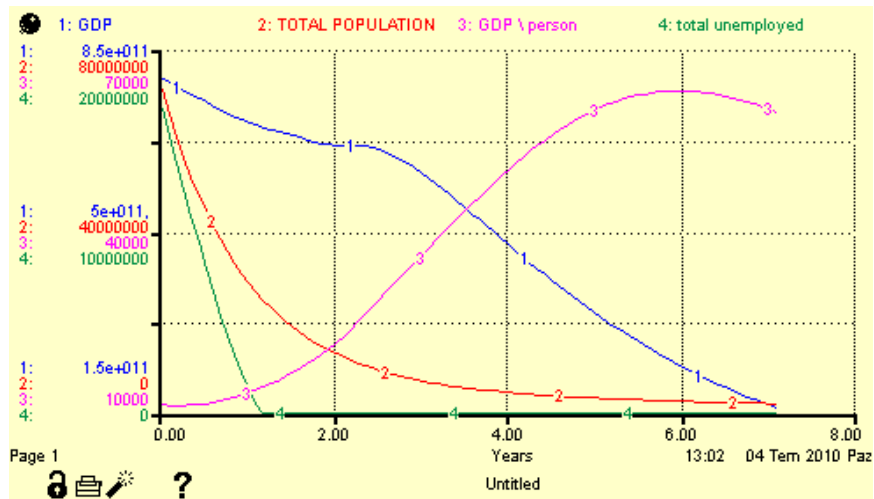

Figure D.14: Extreme Conditions Test Results for mortality. Max = 1

8. Mortal\_0\_to\_5

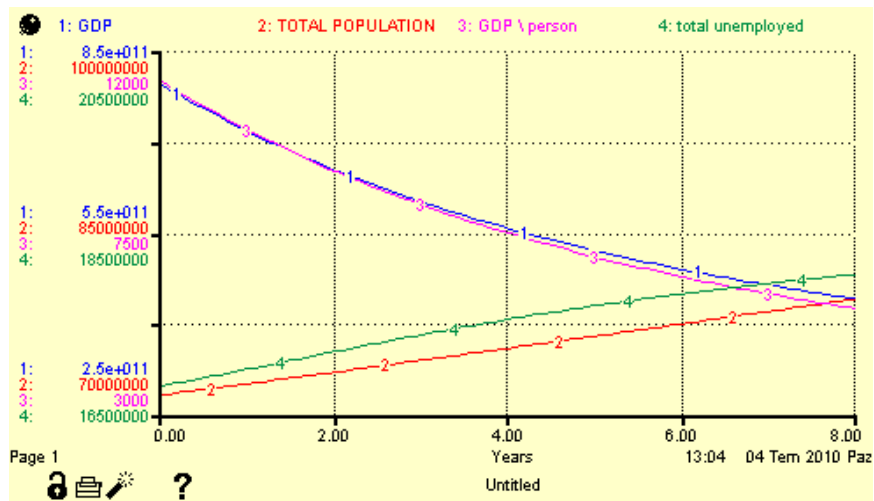

Figure D.15: Extreme Conditions Test Results for mortal\_0.to\_5. Min = 0

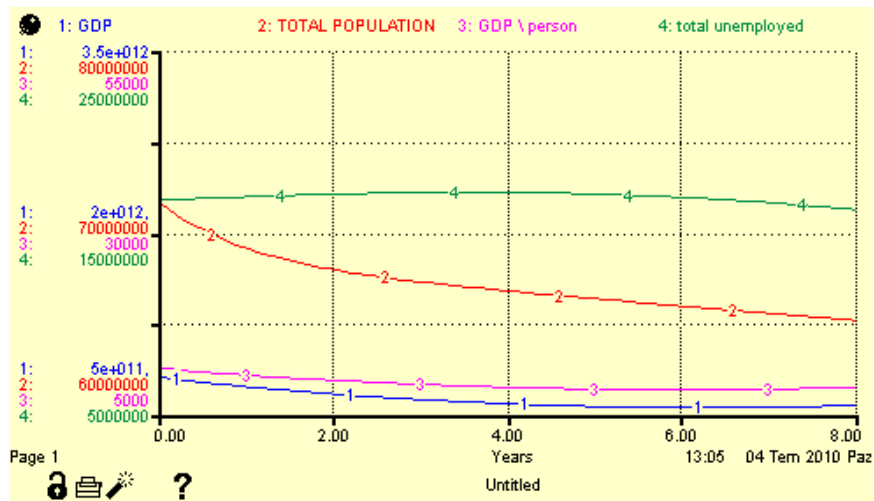

Figure D.16: Extreme Conditions Test Results for mortal\_0.to\_5. Max=1

## Appendix E

### EFFICIENCY MULTIPLIER COMPONENTS RELATIVE WEIGHT ANALYSIS

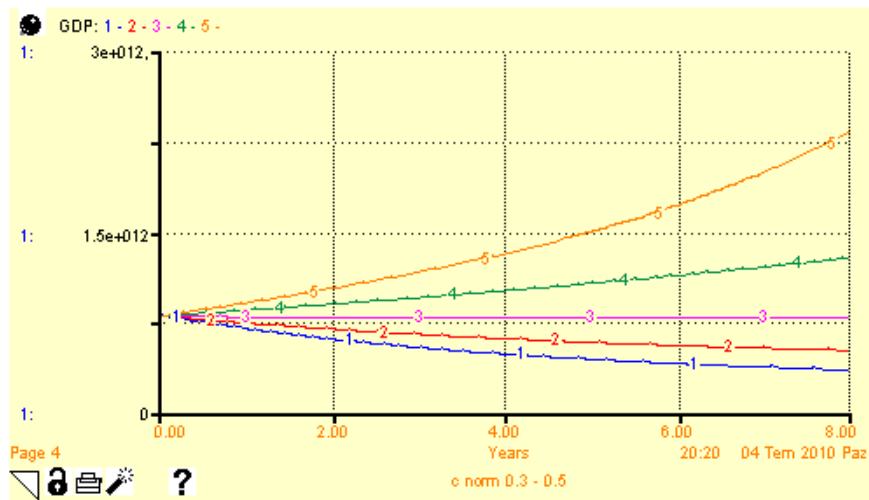

Figure E.1: Sensitivity run for the weight of norm\_other\_sector\_inv\\_all\_workers. Range: [0.3-0.5]



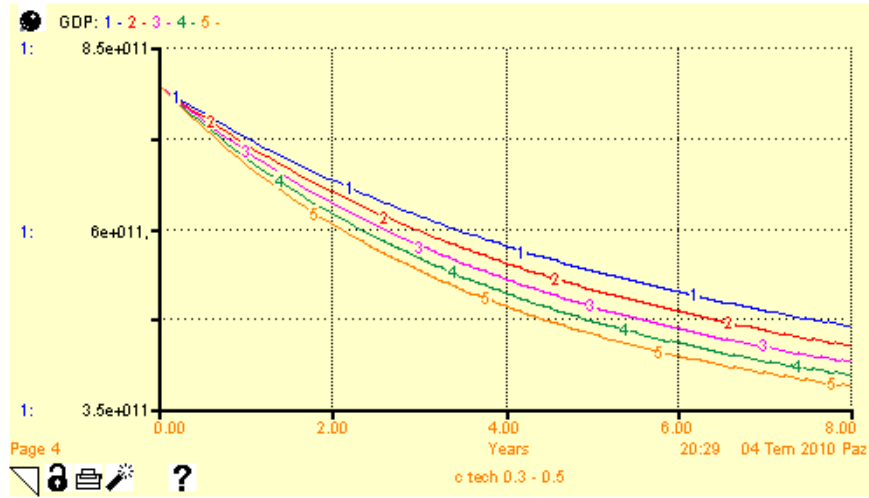

Figure E.2: Sensitivity run for the weight of tech\_indicator. Range: [0.3-0.5]

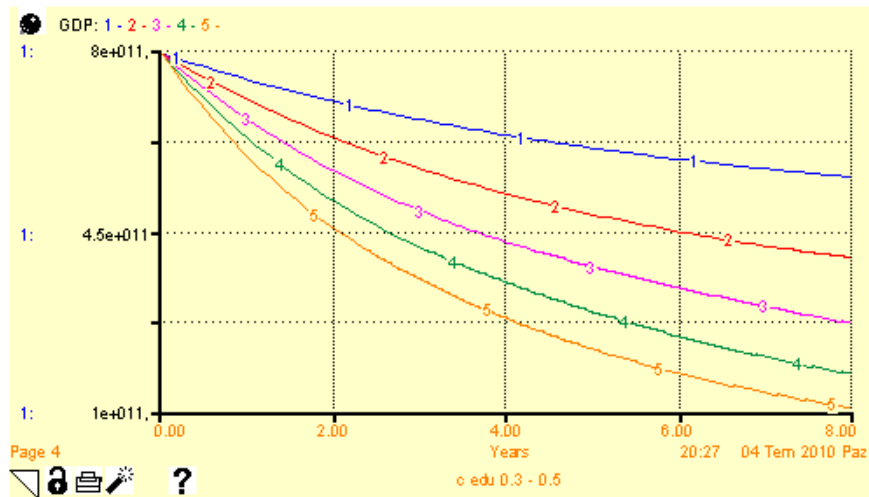

Figure E.3: Sensitivity run for the weight of std\_edu\_quality\_factor. Range: [0.3-0.5]