

THE RESTORATION PROJECT OF UKUR HAMAM IN BİRĐİ

A THESIS SUBMITTED TO
THE GRADUATE SCHOOL OF NATURAL AND APPLIED SCIENCES
OF
MIDDLE EAST TECHNICAL UNIVERSITY

BY

DOĐAN ZİLAN ZCAN

IN PARTIAL FULFILLMENT OF THE REQUIREMENTS
FOR
THE DEGREE OF MASTER OF SCIENCE IN RESTORATION
IN
ARCHITECTURE

SEPTEMBER 2011

Approval of the thesis:

THE RESTORATION PROJECT OF ÇUKUR HAMAM IN BİRGİ

submitted by **DOĞAN ZİLAN ÖZCAN** in partial fulfillment of the requirements for the degree of **Master of Science in Restoration in Architecture, Middle East Technical University** by,

Prof. Dr. Canan Özgen
Dean, Graduate School of **Natural and Applied Sciences**

Assoc. Prof. Dr. Güven Arif Sargın
Head of Department, **Architecture**

Inst. Dr. Nimet Özgönül
Supervisor, **Architecture Dept., METU**

Examining Committee Members:

Inst. Dr. Fuat Gökçe
Architecture Dept., METU

Inst. Dr. Nimet Özgönül
Architecture Dept., METU

Assoc. Prof. Dr. Emre Madran
Architecture Dept., METU

Assist. Prof. Dr. Güliz Bilgin Altınöz
Architecture Dept., METU

Kemal Nalbant, M.Sc
General Manager, Miyar Mimarlık

Date:

13.09.2011

I hereby declare that all information in this document has been obtained and presented in accordance with academic rules and ethical conduct. I also declare that, as required by these rules and conduct, I have fully cited and referenced all material and results that are not original to this work.

Name, Last name: Dođan Zilan Özcán

Signature :

ABSTRACT

THE RESTORATION PROJECT OF ÇUKUR HAMAM IN BİRĞİ

Özcan, Dođan Zilan

M.Sc. in Restoration, Department of Architecture

Supervisor: Inst. Dr. Nimet Özgönül

September 2011, 172 pages

The subject of this thesis study is Çukur Hamam, one of the remarkable edifices in Birgi town in Ödemiş district of İzmir. The aim of the study is to create a restoration project for Çukur Hamam to provide its survival by integrating its neighbourhood to the social life of the city.

During the study the edifice and its periphery was documented carefully by using 3D Laser Scanner. In the historical and comparative study the original status of the edifice was researched.

With respect to the data gathered from the studies, a restoration project which includes the intervention decisions for the conservation of the physical condition and authentic elements of the edifice.

Keywords: Traditional Hamam Architecture, Birgi, Restoration Project

ÖZ

BİRGİ ÇUKUR HAMAM RESTORASYON PROJESİ

Özcan, Doğan Zilan

Yüksek Lisans, Restorasyon, Mimarlık Bölümü

Tez Yöneticisi: Öğr. Gör. Dr. Nimet Özgönül

Eylül 2011, 172 sayfa

Bu tezin konusu İzmir ilinin Ödemiş ilçesine bağlı Birgi kazasında bulunan ve dikkate değer yapılardan biri olan Çukur Hamam'dır.

Çalışmanın amacı Çukur Hamam'ın barındırdığı özgün mimari, kültürel değerlerin, hazırlanacak restorasyon projesi ile bulunduğu çevreyi kentin sosyal yaşamına tekrar katarak ayakta kalmasını sağlamaktır.

Bu çalışma kapsamında, yapı ve çevresi 3D lazer tarayıcı kullanılarak detaylı olarak belgelenmiştir. Yapılan tarihi araştırma ve karşılaştırmalı çalışma ise yapının özgün durumu araştırılmıştır.

Toplanan bilgilerin ışığında, yapının fiziksel varlığının korunması ve özgün unsurlarının ortaya çıkarılmasını sağlayacak müdahale kararlarını içeren bir restorasyon projesi hazırlanmıştır.

Anahtar kelimeler: Geleneksel Hamam Mimarisi, Birgi, Restorasyon Projesi

To my family...

ACKNOWLEDGEMENTS

Firstly, I would like to express my deepest gratitude to my supervisor Inst. Dr. Nimet Özgönül for constant encouragement, constructive criticism, and invaluable supervision. It has been a great pleasure to work with her. I also thank to Assoc. Prof. Dr. Emre Madran, Assoc. Prof. Dr. Neriman Şahin Güçhan, Assist. Prof. Dr. Güliz Bilgin Altınöz, Inst. Dr. Fuat Gökçe, and MSc. Kemal Nalbant for their valuable criticism and suggestions.

I would especially like to thank to Özgür Serkan Uslu who helped me during site survey and Semih Kirişçioğlu for his valuable support from the beginning of this thesis.

I would also like to thank Hatice Çelebi, Pınar Aykaç, Öncü Güney, Filiz Diri, and Ayça Sinal for their support and invaluable friendship.

I am deeply indebted to Mert Nezih Rifaioğlu who encourage me to join this master program.

Most importantly, I would like to thank my parents İsmet Özcan, Nilgün Özcan, my sister Derya Zelal Özcan for their patience, and support, trust, and complimentary love.

TABLE OF CONTENTS

ABSTRACT	iv
ÖZ	v
ACKNOWLEDGEMENTS	vii
LIST OF TABLES	xii
LIST OF FIGURES	xiii
CHAPTERS	
1. INTRODUCTION	1
1.1 BATHING TRADITION AND HAMAM CULTURE	1
1.1.1 DEVELOPMENT OF HAMAM ARCHITECTURE	2
1.2 DEFINITION OF THE PROBLEM.....	10
1.3 AIM AND CONTENT OF THE STUDY.....	12
1.4 SELECTION OF THE BUILDING	13
1.5 METHODOLOGY	13
1.5.1 DOCUMENTATION OF THE BUILDING	13
1.5.2 HISTORICAL RESEARCH AND COMPARATIVE STUDY	17
1.5.3 RESTITUTION.....	17
1.5.4 RESTORATION.....	18
2. GENERAL FEATURES OF ÇUKUR HAMAM.....	19
2.1 LOCATION OF THE BUILDING	19
2.2 THE NEARBY ENVIRONMENT OF THE BUILDING	20
2.3 GENERAL DESCRIPTION	20
2.4 EXTERIOR DESCRIPTION	21

2.4.1	WEST FACADE.....	21
2.4.2	THE SOUTH FACADE.....	22
2.4.3	THE EAST FACADE.....	24
2.4.4	THE NORTH FACADE.....	24
2.5	INTERIOR DESCRIPTION.....	25
2.5.1	SPACE Z01.....	25
2.5.2	SPACE Z02.....	28
2.5.3	SPACE Z03.....	30
2.5.4	SPACE Z04.....	32
2.5.5	SPACE Z05.....	35
2.5.6	SPACE Z06.....	37
2.5.7	SPACE Z07.....	39
2.5.8	SPACE Z08.....	42
2.5.9	SPACE Z09.....	44
2.5.10	SPACE Z10.....	46
2.5.11	SPACE Z11.....	48
2.6	ARCHITECTURAL ELEMENTS.....	59
2.6.1	DOORS.....	59
2.6.2	WINDOWS.....	61
2.6.3	NICHES.....	61
2.6.4	SEKI.....	61
2.6.5	KURNA.....	62
2.7	STRUCTURAL SYSTEM, CONSTRUCTION TECHNIQUE AND MATERIAL USE OF THE BUILDING.....	62
2.7.1	WALLS.....	63
2.7.2	TRANSITION ELEMENTS.....	65
2.7.3	SUPER STRUCTURE.....	65

2.8	HEATING SYSTEM	72
2.8.1	KÜLHAN.....	72
2.8.2	CEHENNEMLİK.....	72
2.8.3	TÜTEKLİK.....	72
2.9	WATER DISTRIBUTION AND DISPOSAL SYSTEMS.....	74
2.9.1	CLEAN WATER DISTRIBUTION SYSTEM	74
2.9.2	WASTE WATER DISPOSAL SYSTEM.....	74
2.10	MATERIAL DECAYS AND STRUCTURAL PROBLEMS	76
2.10.1	MATERIAL CONDITION OF THE BUILDING.....	77
2.10.2	DECAY FORMS	77
2.10.3	STRUCTURAL STATE OF THE BUILDING.....	79
3.	HISTORICAL RESEARCH.....	88
3.1	HISTORY OF BİRGİ.....	88
3.2	PRESERVATION ACTIVITIES IN BİRGİ.....	92
3.3	HISTORY OF CUKUR HAMAM.....	93
3.4	COMPARATIVE STUDY	93
3.4.1	PLAN LAYOUTS.....	95
3.4.2	HEATING SYSTEM AND WATER INSTALLATIONS	100
3.4.3	WATER INSTALLATION SYSTEMS	101
3.4.4	ARCHITECTURAL ELEMENTS	102
3.4.5	MATERIAL AND CONSTRUCTION SYSTEM.....	105
3.4.6	EVALUATION.....	105
4.	RESTITUTION	106
4.1	CHANGES IN THE BUILDING.....	106
4.1.1	CLUES	107
4.1.2	EVALUATION OF CLUES	115
4.2	RESTITUTION	125

4.2.1	ORIGINAL STATE OF THE BUILDING.....	126
4.2.2	FIRST GROUP INTERVENTIONS	127
4.2.3	SECOND GROUP INTERVENTIONS	127
4.2.4	EVALUATION OF INTERVENTION GROUPS	127
4.3	RELIABILITY OF THE RESTITUTION	143
5.	RESTORATION APPROACHES.....	145
5.1	EVALUATION OF THE TOWN	146
5.2	EVALUATION OF THE BUILDING ENVIRONMENT.....	146
5.3	EVALUATION OF THE HAMAM	149
5.3.1	VALUES	149
5.3.2	POTENTIALS	150
5.3.3	PROBLEMS.....	151
5.4	GENERAL RESTORATION APPROACH	151
5.4.1	PRINCIPLES RELATED TO CONSERVATION.....	152
5.4.2	PRINCIPLES RELATED TO RESTITUTION PERIODS	152
5.4.3	PRINCIPALS RELATED TO NEW FUNCTION	152
5.5	INTERVENTION DECISIONS.....	153
5.5.1	DECISIONS RELATED TO CONSERVATION	153
5.5.2	DECISIONS RELATED TO RESTITUTION	154
5.6	NEW FUNCTION.....	155
5.6.1	DECISIONS RELATED TO NEW FUNCTION	155
5.6.2	EVALUATION OF THE SPACES	155
5.6.3	INSTALLATIONS	158
	REFERENCES.....	166
	APPENDIX.....	169
A.	COMPARATIVE STUDY CHARTS.....	169

LIST OF TABLES

TABLES

Table 1, Door Types.....	60
Table 2, Evaluation of Clues.....	120
Table 3, Reliability of Restitution Periods.....	144

LIST OF FIGURES

FIGURES

Figure 1. Public Bath of Pompei	4
Figure 2, Schematic hypocaust system of a Roman bath.....	5
Figure 3. Istanbul, Kalenderhane Hamam plan and restored perspective.....	6
Figure 4. S. Eyice Categorization of Ottoman Hamams	9
Figure 5, Graphical Documentation	16
Figure 6 Location of Birgi in Turkey Map.(Aegean region map is gathered as template from www.kgm.gov.tr).....	19
Figure 7, Aerial Photograph of the Nearby Environment. (Google Earth, 2011).....	20
Figure 8, West Facade of Çukur Hamam,.....	21
Figure 9, South Facade of Çukur Hamam.....	23
Figure 10, East Facade of Çukur Hamam	24
Figure 11, North Facade of Çukur Hamam.....	25
Figure 12, Space Z01	27
Figure 13, Space Z02	30
Figure 14, Space Z04	34
Figure 15, Measured Drawing, Plan	50
Figure 16, Measured Drawings, Ceiling Plan	51
Figure 17, Measured Drawings, Roof Plan.....	52
Figure 18, Measured Drawings, Facades	53
Figure 19, Measured Drawings, Section AA and BB	54
Figure 20, Measured Drawings, Section CC, DD, EE.....	55
Figure 21, Measured Drawings, Section FF, GG, HH.....	56
Figure 22, Measured Drawings, Section II, JJ, KK	57
Figure 23, Measured Drawings, Section LL, MM, NN	58
Figure 24, Distribution of Architectural Elements.....	59
Figure 25, Load Bearing Wall Thickness Distribution	63

Figure 26, Construction Technique and Material Use Legend.....	67
Figure 27, Construction Technique and Material; Floor Covering and Finishing.....	68
Figure 28, Construction Technique and Material; Domes.....	69
Figure 29, Construction Technique and Material; Superstructure.....	70
Figure 30 Construction Technique and Material; Distribution of the System.....	71
Figure 31, Heating System.....	73
Figure 32, Clean Water Distribution System.....	75
Figure 33, Deterioration Legend.....	76
Figure 34, Deterioration Mappings, Plan.....	80
Figure 35, Deterioration Mappings, Roof Plan.....	81
Figure 36, Deterioration Mappings, Facades.....	82
Figure 37, Deterioration Mappings, Section AA, BB, CC.....	83
Figure 38, Deterioration Mappings, Section DD, EE, FF.....	84
Figure 39, Deterioration Mappings, Section NN, GG, HH.....	85
Figure 40, Deterioration Mappings, Section II, MM, JJ.....	86
Figure 41, Deterioration Mappings, Section KK, LL.....	87
Figure 42, Clues Study; Plan.....	111
Figure 43, Clues Study; Section CC.....	112
Figure 44, Clues Study; Section DD.....	113
Figure 45, Clues Study; Section JJ.....	114
Figure 46, Clues Study; Section HH.....	115
Figure 47, Evaluation of Clues, Mapping at Plan.....	121
Figure 48, Evaluation of Clues, Mapping at Section CC.....	122
Figure 49, Evaluation of Clues, Mapping at Section DD.....	123
Figure 50, Evaluation of Clues, Mapping at Section HH.....	124
Figure 51, Evaluation of Clues, Mapping at Section JJ.....	125
Figure 52, Legend of Restitution Drawings.....	127
Figure 53, Restitution Drawings; Floor Plan.....	128
Figure 54, Restitution Drawings; Roof Plan.....	129
Figure 55; Restitution Drawings; <i>Cehennemlik</i> Plan.....	130
Figure 56; Restitution Drawings; West Facade.....	131
Figure 57; Restitution Drawings; East Facade.....	131
Figure 58; Restitution Drawings; South Facade.....	132

Figure 59; Restitution Drawings; Section AA	133
Figure 60; Restitution Drawings; Section BB.....	134
Figure 61; Restitution Drawings; Section CC.....	135
Figure 62; Restitution Drawings; Section DD	136
Figure 63; Restitution Drawings; Section EE	137
Figure 64; Restitution Drawings; Section FF.....	138
Figure 65; Restitution Drawings; Section GG	139
Figure 66; Restitution Drawings; Section HH	139
Figure 67; Restitution Drawings; Section II	140
Figure 68; Restitution Drawings; Section JJ.....	140
Figure 69; Restitution Drawings; Section KK	141
Figure 70; Restitution Drawings; Section LL	141
Figure 71; Restitution Drawings; Section MM.....	142
Figure 72; Restitution Drawings; Section NN	142
Figure 73, Historical Monumental and Industrial Buildings	147
Figure 74, Borders of Birgi Master Plan.....	148
Figure 75. Evaluation of the spaces in terms of circulation layout.....	156
Figure 76. Evaluation of spaces in terms of illumination	157
Figure 77. Evaluation of spaces in terms of areas.....	158
Figure 78; New Function; Section DD.....	159
Figure 79; New Function, Section GG.....	159
Figure 80, Restoration Project, Floor Plan.....	160
Figure 81, Restoration Project, Roof Plan	161
Figure 82, Restoration Project, Section II.....	162
Figure 83, Restoration Project, Section JJ	163
Figure 84, Restoration Project, Section GG.....	164
Figure 85, Restoration Project, South Facade.....	165
Figure 86 Comparative Study Chart 1	169
Figure 87 Comparative Study Chart 2	170
Figure 88 Comparative Study Chart 3	171
Figure 89 Comparative Study Chart 4	172

CHAPTER 1

INTRODUCTION

1.1 BATHING TRADITION AND HAMAM CULTURE

Since the ancient times there has been a strong association between the religion and bathing. In the Avesta the holy book of old Persian Zoroastrianism and in the Indian holy book Dharma Sashtra the body cleaning is a religious obligation. According to a continuing Indian tradition, bathing in Ganges is a holy practice; every year Hindus gather here bath in the Ganges and then go to worship in the temples on the banks of the river. The water structures and baths built for similar reasons were found in Seylon Island and in the royal city of Anaradhapura. It is well known that Jews built baths due to the religious reasons and paid attention to the spas. Bethesda baths in Jerusalem is among them. The old scriptures spoke of a spa which was belonged to the queen of Saba. In Syrian temples there were bathing places for the worshipers and sacrifice givers. There were stone bathing cabinets in the courtyard of the Sun temple in Baalbek. Bathing in the river Nile was blessed in the Ancient Egypt. In addition to that bathrooms were found in some of the remains of Egyptian temples.¹

Throughout the history, bathing activity has always been in mankind's agenda, therefore closed and open spaces for bathing in different size and configuration were in the mankind's architectural program. Especially in Anatolia and the Middle East where was on the movement route of Pre-Ottoman Turks and later the early Ottoman state engaged in, there was a very old bath tradition. Due to the needs of cleaning, refreshment, therapeutical and recreational activities and religious duties, the demand on bathing and of bathing spaces existed for centuries in Greek, Roman, Byzantine,

¹ K. Aru, 1949, p.10

Early Islamic, Seljukid and Ottoman periods and continued through the modern times.²

“Hamam” is lexically defined as “the space for bathing, bathroom, and the space for bathing in charge of money”. It was derived from the Arabic word *hamm (hamem)* as hammam which means “to heat, being hot”.³

1.1.1 DEVELOPMENT OF HAMAM ARCHITECTURE

1.1.1.1 PUBLIC BATHS IN ANTIQUITY

In the remains of ancient civilizations, the spaces of bathing are remarkable. For instance, there was very sophisticated water and drainage system in Mohenjo-Daro which was an important city of Indus civilization from BC 2500-1500 that was dug out in the excavations in Sind, West Pakistan. In the old Mesopotamia, an Assyrian bathing facility and at the bank of Tigris, remains of a bath in the palace of Salmanasar III (BC 859-824) were found. Bath remains also exist in Tell Amarna, Egypt. In Tell Halaf near the town of Resul Ayn at the Turkish-Syrian border, the bathing spaces, clean water and sewage installations and earthen bathtubs from 3rd century BC were found in city’s residential area. In Gaziantep, a Zincirli excavation a baths which is dated to Hitite Principalities period (circa BC 1200) was found.⁴ .

1.1.1.2 PUBLIC BATHS IN GREEK AND ROMAN PERIODS⁵

Bathing spread and became important in the ancient Greece. Greeks used water for cleaning the body and soul and benefitted from its relaxant character.⁶

In the Classical period social activities as well as the body care and sports were paid importance. Special sporting baths for swimming were built at the seashores and

² Seda Kula Say, 2007, pp. 10-27

³ Türk Dil Kurumu "Hamam" maddesi Güncel Türkçe Sözlük; www.tdk.gov.tr

⁴ Semavi Eyice, 1997, p. 413

⁵ For more information on Roman baths please refer to F. Yegül’s insightful study “Antik Çağ’da Hamamlar ve Yıkanma” (2006)

⁶ H. Abbasoğlu, 1998

riverbanks. The Greek city founders built cold and hot water baths as inevitable parts of gymnasiums where the athletes take bath after the sport exercises.⁷

Baths as an independent edifice emerged in the Roman period. Romans although did not pay attention to baths at the beginning later started to built huge structures imitating the Greek prototypes.⁸

Roman baths consist of several parts. In front of the baths there is a colonnaded (porticus) courtyard (palaestra) for sport games and wrestling matches. After passing the main gate at the courtyard, the first space is *Apoditerium* the dressing room. At the corner the service room is located and along the walls there are coaches. Apoditarium leads to Frigidarium, *soğukluk*. In the centre of this ample space which is reserved for bathing with cold water, there exists a pool (natatio) which sometimes is big enough for swimming. In front of the walls statues are aligned. This place is followed by warm Tepidarium. The warmest part of the bath is Caldarium.

Caldarium is surrounded by private cells. There is also very hot room Sudatorium for sweating with evaporation. The furnace which provides hot water and hot air is named as praefurnium. The Roman baths with a garden backside was built for not only a place for bathing but also for conversation and debate, an auditorium for philosophers, poets and rhetors and for an entertainment facility for society.⁹

⁷ Tülay Taşçıoğlu, 1998, p. 24

⁸ K. Aru, 1949, p.12

⁹ F. Yegul, 2006, p.59

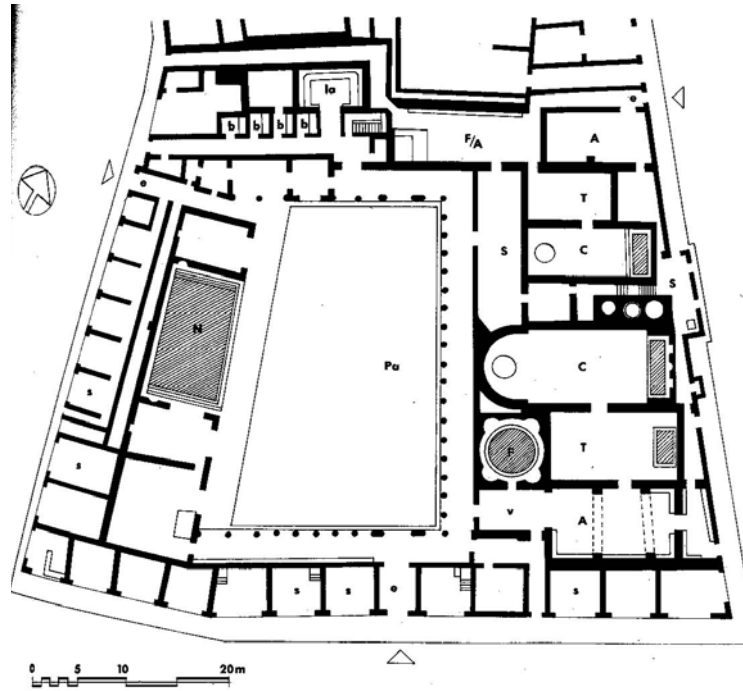


Figure 1. Public Bath of Pompeii¹⁰

The biggest similarity between Roman baths and Islamic Turkish baths is the heating system. The floor of Caldarium is located upon the overlapped brick piers. The hot air obtained by burned woods is circulated through these brick piers in the basement which is called hypocaustum and heats both tepidarium and caldarium. The smoke is and the vapour is exhausted with the aid of earthen pipes which are installed in the walls. Although these conditions are sufficient for the small sized edifices, in the huge baths auxiliary canals and furnaces are added.¹¹

¹⁰ Ibid., p.62

¹¹ S. Eyice, 1997, pp 402-403

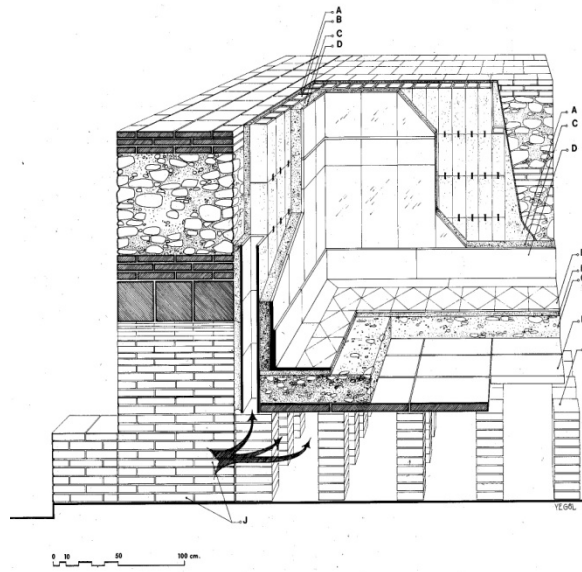


Figure 2, Schematic hypocaust system of a Roman bath¹²

1.1.1.3 PUBLIC BATHS IN THE BYZANTINE PERIOD

Byzantines although generally using the baths from the Roman period, built new ones¹³. These baths are continuations of the Roman period. Some of these Byzantine baths are Constantinus, Arcadius, Zeuxippos and Eudoksiya baths.¹⁴ Byzantines likewise their predecessors paid great attention on ornamentation. Besides the public baths, there were private baths built in houses and palaces.¹⁵

Likewise Byzantines inherited the bath buildings from Romans Turks learned baths from Byzantines in their first encounter in 11th century and developed it. The Turkish bath which is very similar to the Roman bath with respect to the spatial features is contextually very distinct due to the religion and tradition.¹⁶

¹² F. Yegül, 2006, p. 89

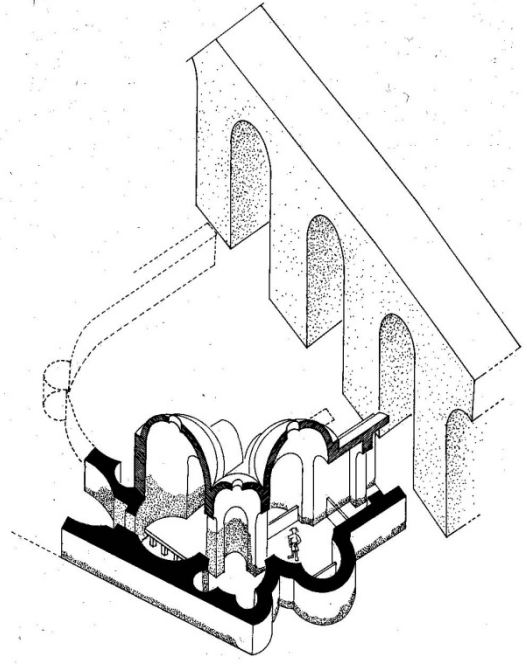
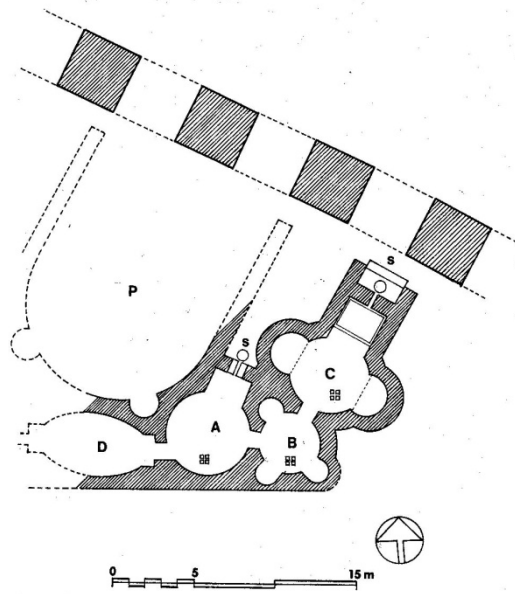
¹³ T. Taşçıoğlu, p. 32

¹⁴ BE-SE, Bizans Hamamları, Türkiye Turing ve Otomobil Kurumu Belleteni, 110/1951, s.13

¹⁵ S.Atlı, 1990, p.10

¹⁶ Ş. Güvenç, 1997, p.21

Fig. 413 Kalenderhane Baths,
Istanbul (courtesy of C.
Striker).
a. Plan (Yegül after Striker).



b. Restored perspective study
(Yegül after Striker).

Figure 3. Istanbul, Kalenderhane Hamam plan and restored perspective¹⁷

1.1.1.4 PUBLIC BATHS IN THE SELJUKID PERIOD

There is no information for the types of baths that Turks built in their habitats before conquering Anatolia. However we can read from the publications that Turkish nomads had tent-baths named *çerge* and Sultan of Anatolian Seljukids Alaaddin Keykubat I used a tent-bath in his expeditions called Hamam-ı Seferi.¹⁸

Artukids built the first examples of Turkish bath in southeastern Anatolia. Maristan Hamam which was built in the beginning of 12th century in mardin is agreed to be the oldest Turkish bath in Anatolia. A bath with gold mosaic ornamentations was found by Oktay Aslanapa during the excavations in Diyarbakır Artukid Palace which was built between 1220 and 1222. Very few bath edifices survived from the Seljukid period. Kölük Hamam in Kayseri is actually a Danismendid building however due to its dense reconstruction in 1210 it can be count as a Seljukid edifice. It was built in

¹⁷ F. Yegül, 1992, p.301

¹⁸ O. Turan, 2003, p.130, p.370,

twin-baths (çifte hamam) plan. Kümbet Hamam (Kayseri), Sultan Hamam (Kayseri), İçkale Hamam (Alanya) and Alara Kalesi Hamam (Alanya) are other important examples.¹⁹ In addition to that the sources speak of a Great Seljukid bath in Nigar south of Kirman, Iran.²⁰

The *sıcaklıks* of *çarşı hamams* of Seljukids and the Principalities period generally followed the old plan of Turkish art which consists of four iwan and *halvet* cells on the corner.²¹

1.1.1.5 HAMAMS IN THE OTTOMAN PERIOD

Ottomans built many water structures including aquaducts, maslaks, maksems, fountains, cisterns and among them they paid great attention to the baths.²²

There are two reasons for Ottomans built many baths through their history. Firstly the baths were devoted to the pious foundations as a means of income and secondly they served to the congregation of the mosques which together with the baths and other buildings constituting the building complexes (*külliyeye*). However these facilities were used as long as they produced income and when they lost this value they were quit. It is well known that baths which were one of the most hilarious typologies of Ottoman architecture were abandoned due to these reasons.²³

Ottoman baths can be separated as;

- “çarşı hamams” for public service
- “private hamams” built in palaces, kiosks and houses
- “spas”, those were used for bathing and therapy.²⁴

Çarşı Hamams were built as twinbaths. In twinbaths which one part serves for males and the other part serves for females the entrances leading to the same street was avoided. Due to prevent the heat losses other than some exceptions these two parts

¹⁹ Büyük Larousse Sözlük ve Ansiklopedisi, 1986, "Hamam" maddesi.

²⁰ Y. Önge, 1995, p.9.

²¹ Semavi Eyice, 1997, p.420

²² Ibid.

²³ Ibid.

²⁴ Birsen Erat, 1999, pp.390-392

are completely connected. Few single-baths served males and females in different hours.²⁵

Çarşı hamams are social edifices which function as means of income to the building complexes (külliye) in the pious foundation system.²⁶

Private baths are designed independent or semi-dependent structures in buildings such as palace, kiosk, caravanserai, dervish lodge, and military barracks. Since they were aimed to serve few people they were not designed with typological hesitations.²⁷

Semavi Eyice categorized the Ottoman bath plans according to their *sıcaklık* which he considers as the most important part;

A- Cross-axial plan with four *iwans* and four corner units (*halvet*). In this plan, it is also possible to see the variations including two *halvets* and single, two or three *iwans*.

B- *Sıcaklık* with a star-shaped plan type. It has a polygonal plan with variable side number. Deep niches covered with vaults in the shape of *iwans* are placed around this polygonal plan.

C- *Halvets* arranged around a square planned main *sıcaklık* space in square plan type. This plan type consists of a square main *sıcaklık* space and *halvet* on one, two or three side of it.

D- Multi-domed *sıcaklık*. The domed main *sıcaklık* space consists of domed side spaces and *halvets*.

E- The plan has *soyunmalık*, *sıcaklık* and *halvets* of the same size. All spatial components of hamam are approximately in the same sizes. These spaces is connected to each other and covered with domes.

F- The type of plan that has elongated rectangular *sıcaklık* with a domed central unit and two *halvets*²⁸.

²⁵ Semavi Eyice, 1997, p. 421

²⁶ Y.Önge, 1971, p. 6

²⁷ Birsen Erat, 1999, p.393

²⁸ S. Eyice, 1960, pp. 99-116

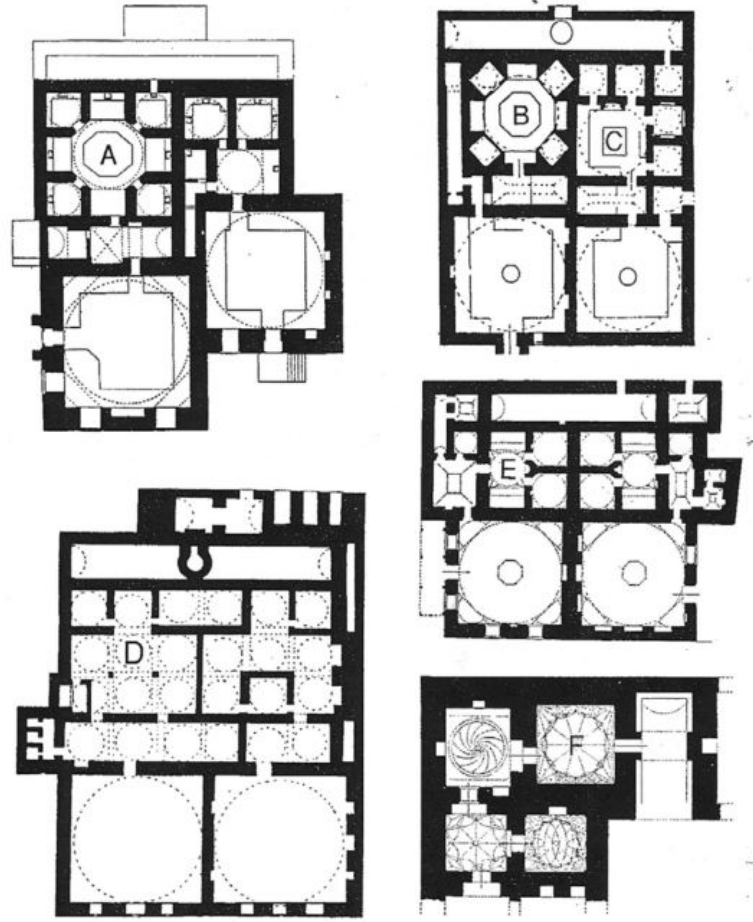


Figure 4. S. Eyice Categorization of Ottoman Hamams

Spas have the similar architectural plan with *çarşı hamams*. In some examples there are not *halvetlik* and *ılıklik* parts.²⁹

In the Early Ottoman architecture both Oguz Turk's, experiences which they had gained in the lands they have wander about, and Anatolia's cultural and architectural tradition going back centuries ago and then existing cultural atmosphere and demographic structure were influential. Besides it would not be wrong to suggest that the conditions and the medium of art of the previous period were still in charge.

In this manner, early Ottoman architecture's building program, material usage, detailing, structuring and the transition elements were strongly influenced by Central

²⁹ Birsen Erat, a.g.e.,1999

Asian, Chinese, Indian, as well as Persian, Caucasian, Armenian, Syrian and Seljukid traces and interpretations can be observable.³⁰

When considering Semavi Eyice's typology for the baths built in early period, the majority is type A and its variations together with type E which has twin *halvet* cells. In this period *soyunmaliks* with great domes were built. In Gelibolu Sarıca Paşa Hamam, Bursa Atpazarı Hamam and Edirne Tahtakale Hamam the diameters of domes in male's parts are between 10 to 15m.³¹

On the other hand in the Ottoman Classical period symmetrical planned twinbaths became important and the dimensions of baths were enlarged. Although not as sophisticated as the early examples, in the classical period ornamentation and covering systems rich.³²

The *aralık* space which was one of the most important features of the early period became smaller and at the end replaced with *ılıklik* in 16th century. In classical period baths; at the centre *şadırvan*, *soğukluk* at the sides changing rooms, *ılıklik* where the toilets are located and *pestemals* were being changed, *sıcaklık* wherein *göbektası* and *kurnas* are posited and lastly kulhan attached to *sıcaklık* was observable.³³

1.2 DEFINITION OF THE PROBLEM

Historic buildings are living witnesses of their age-old traditions³⁴ embracing architectural, functional, social, and economic features of their period. In other words, they are the physical evidences of space use, material use, construction techniques as well as social life. Thus, "the values of the historic buildings are not only in their appearance, but also in the integrity of all their components as a unique product of the specific building technology of their time³⁵". As it is stated in the

³⁰ S. Kula Say, 2007,

³¹ Semavi Eyice, 1997, p. 422.

³² Anadolu Uygarlıkları Ansiklopedisi, Anadolu Türk Mimarisi, Cilt 5, Sayfa 848

³³ Ibid.

³⁴ ICOMOS (1964) International Charter for the Conservation and Restoration of Monuments and Sites, Venice Charter.

³⁵ ICOMOS (2003) ICOMOS Charter, Principles for the Analysis, Conservation and Structural Restoration of Architectural Heritage.

Venice Charter, the intention of conservation of historic buildings is “to safeguard them no less as works of art than historical evidence³⁶”

From the Roman period onwards, public baths constitute the major public buildings in the urban life of different civilizations. Due to their specialized function, public baths constitute explicit sequence of spaces with specific uses, original technologies of functional systems of their time³⁷ such as heating, water supply and drainage systems etc. Therefore they can be regarded as exceptional building types of their period.

For the case of Ottoman hamams, they are the one of the major building types and have a central place for social life with complex urban and societal relations³⁸. Due to the specific requirements of hygiene understanding of Islamic bathing tradition, the Ottoman hamams are unique in terms of their architectural layout, building materials, construction techniques, and installations related to water supply and disposal, heating, and illumination indigenous to their specific function.

“Contemporary conservation practice as defined by international doctrine such as the Venice Charter has tended toward considering and admiring works of art and architecture as documents, thus placing increased importance on their material expression of authenticity³⁹”.

Accordingly, while restoring hamam buildings, their historic, documentary, research and educational value should be taken into special consideration due to their unique architectural and technical aspects. However in Turkey, most of the conservation projects and implementations do not generally consider authenticity in terms of material use, construction techniques as well as different periods of the building’s history. Instead, the most common conservation approach is the consolidation of the existing remains and reconstructing the missing architectural features of the buildings with respect to their first creation periods. Indeed, the current conservation practices in Turkey is a major debate between the specialists from 2004 Amendment

³⁶ ICOMOS (1964) International Charter for the Conservation and Restoration of Monuments and Sites, Venice Charter.

³⁷ G. Dişli, 2008, p.3

³⁸ Samir F. et al., 2007, pp. 201-216.

³⁹ Matero F. G., 2007, p.53

of the 2863 Conservation Act allowing new tools for conservation implementations and new resources for conservation. As a consequence, most of the public buildings have started to be restored from those years rapidly onwards.

For the case of hamams, the restoration interventions generally do not take into account the inherent values of these unique buildings especially for the ones that embrace educational and research potentials with their ruined condition. Since there are not many sources giving detailed information on the water supply-drainage systems, illumination, heating, specialized architectural features etc. in terms of their details, specific construction techniques, material uses, dimensions etc., the hamams in ruined condition can be regarded as the major documents to comprehend the operational systems of this building type.

However, most of the restoration projects and interventions aim to achieve wholeness or completeness⁴⁰ of the building, not aiming to present the inherent qualities of hamams as mentioned before by disregarding their historic and educational values. By the rapid increase of restoration projects and implementations in Turkey with the current conservation of achieving completeness, hamams as the foremost evidences of bathing culture of the Ottoman period will lose their documentary and educational values.

1.3 AIM AND CONTENT OF THE STUDY

“Conservation’s primary obligation is to extend the whole life of the work, which in addition to the creative energies of original and subsequent artistic intent, must also embrace the equally long and complex history of its reception over time⁴¹”.

Within this framework, the aim of the thesis is to identify/develop restoration principles in order to reveal specific architectural, functional, and technical aspects through a selected hamam building embracing presentation potential of these aspects as well as preventing the loss of its documentary, research, and educational values.

⁴⁰ Ibid. p.50

⁴¹ Ibid., p.55

Focusing on this aim, the thesis is structured by considering the restoration process of historic buildings which is; documentation, analyses, historical research, comparative study, evaluation of the building, restitution, and finally the identification of the restoration approach and principles through a case study.

1.4 SELECTION OF THE BUILDING

As the case study of the thesis, Çukur Hamam which is located in Birgi is selected. The building is one of the three hamams in Birgi. When it is compared with the other hamams in Birgi, due to its current physical and structural condition; Çukur Hamam reveals sufficient information about construction technique and material use, water distributions and disposal systems and heating system specific for hamam buildings. Therefore the building embraces authentic qualities of hamams as well as educational, research, and educational value constituting presentation potential. Besides, defining restoration principles for presentation will be a basis for evaluating the regions' traditional hamams as well as developing restoration approaches for them.

In addition, municipality of Birgi initiated a street project for Okul Street where Çukur hamam is located. After completing traditional houses, Derviş Ağa Madrasa and Çukur Hamam is going to be in the agenda of Municipality. Thus, defining restoration principles for the building is essential both for the conservation of its inherent qualities, and to provide guidance to Birgi Municipality for its future restoration project.

1.5 METHODOLOGY

1.5.1 DOCUMENTATION OF THE BUILDING

Instead of the traditional manual surveying methods, a laser scanner (Reigl Lms 390i) is used for the preparation of the measured drawings. The device was used to accelerate, facilitate and also to raise the accuracy of the measurements.

Reigl Lms 390i has a capacity of measuring between 1m to 400m distance with minimum step angle of 0,002 degree and 11000 (max) points per second, also has a

range of 80 degrees vertically, 360 degrees horizontally. Laser scanner gives the possibility of measuring every mm in vertical and horizontal according to the distance between the surface and the scanner.

This tool gives the chance of getting every curl and the thickening or slimming at the surfaces. Also with other methods creating orthographic photos is not possible as easy as laser scanning systems on nonlinear surfaces. 3D laser scanner creates orthographic photos by dressing the photo which it takes while measuring to the mesh done according to the taken points from the surfaces. As a comparison at single image rectification most of the programs needs minimum 4 and maximum point number is up to the user and at Riegl Lms 390i gets approximately 1 900 000 points at one session and prepares the orthographic image by using all of the points.

1.5.1.1 SITE SURVEY

The site survey was held in the March of 2009. This four-day work first started with the exterior walls measured with the laser scanner and continued with the roof and ended with the interior spaces.

As mentioned before, in the measurements Riegl Lms 390 laser scanner was used. This device records not only the coordinate points of the measured place but also the color data with the digital camera mounted upon it. Like in the other optical devices, the scanner records only the area it scopes. That is, the spaces behind the obstacles (tree, human, wall etc.) should be measured in a secondary session.

The linking of the sessions in different zones are made through the tie points. Before the start of the measurement the intensity and dimensions of tie points are defined in the software (RiScan) of the device. Therefore these points can be automatically or manually selected in the software and the measures can be taken. Detailed scanning is made to determine the exact locations and the dimensions of the tie points. After holding this process in two sessions, the common points in different sessions can be linked via RiScan Pro software's find corresponding points tool in TPL SOCS page.

The measurement of the facades was started with the south facade. The laser scanner was located 6-8 meters away from the facade and the angle of 0.080 degree was scanned. The distance between two sessions was kept in 5-7 meters. In each session five photographs were taken. In the course of facade measurements via the tie points located around the edifice the sessions on the roof were linked with the measurements on the ground. To record the entire super structure, one session on the center of each dome and two sessions on the water tank were held.

After finishing the roof, the measurement of the interior spaces was started. The external tie points were linked with the interior tie points via the session held at the middle of the gate, located on the west wall of Z02. To link the sessions in interior spaces additional sessions at the passages between the spaces were held. Except the session taken at the center of the space, the device was inclined to 90⁰ and under the domes and vaults additional sessions were held to complete the scanning of the superstructure.

1.5.1.2 GRAPHICAL DOCUMENTATION

In the frame of this work, the point cloud gathered with laser scanning system is converted to a *.pod file by using Pointools View Pro and animations are done by using this program. The colored points in the scan positions which are predefined in Riscan *.Rsp file were imported to Pointools View Pro individually. *.Pod file can be opened in Autocad by using a plug-in software "Pointools Model For Autocad".

In the drawing work the point clouds and orthographic pictures were used. These pictures were rendered by using Riscan Pro software. At this stage the undistorted pictures are imported on the mesh surfaces gathered from the point clouds. At the end of this process we produce a true-colored model. We form the orthographic pictures from the colored point clouds and planes parallel to the surfaces of which we desire to take ortophotos. These pictures can be used to produce drawings from floor plans, ceiling plans, sections and elevations.



Figure 5, Graphical Documentation

In this case, the floor plans are drawn directly using Pointools model for autocad plug-in with autocad. The sections and elevations are drawn with both by the help of the plug in and orthographic pictures created by Riscan Pro, the ceiling plans are directly drawn by the orthographic pictures.

1.5.1.3 ANALYSES

Analyses are made to understand the features of Çukur hamam. These analyses are gathered in three groups. All these analyses are done depending on visual observations.

First group analyses are architectural features of the hamam , the architectural elements are grouped according to their types. This typological study is done in order to define the properties of the elements including materials and construction technique. Structural system, construction technique and material use of the building are discussed together in this part also. This is because the construction technology, the materials used at building are highly related to the structural system and construction technique of the hamam. Details related to construction techniques and material use of the building are drawn and supported with photographs. Also a mapping which is defining the construction technique and material use of the building is given onto the measured drawings.

At second group analyses, heating system and water installation systems are defined. The definition of the heating system is made according to the parts of his system. The water installation systems are handled in two different parts. At first the waste water disposal system is defined, then the clean water distribution system is evaluated.

Material decay and Structural problems are evaluated in third group of analyses. The weathering forms on the site and mapping of the observations onto the survey drawings are done in result. By mapping, the distribution of the decays throughout the building is visualized in order to understand the causes and factors of the problems.

1.5.2 HISTORICAL RESEARCH AND COMPARATIVE STUDY

Historical research includes historical background of Birgi, Çukur Hamam and Bathing tradition and Hamam culture. Written and illustrated sources about Birgi had been researched. This research began with ancient period, detailed at ottoman period and ends at 20th century.

As far as the building concerned, in contrast to a large number of written sources about Birgi, there is almost no written document found regarding the history of Cukur hamam.

1.5.3 RESTITUTION

Restitution is done in order to understand the original physical aspects of the building and the later interventions in the entire life of it until it comes to the current state. This chapter consists two major stages; evaluation of clues and the historical periods of buildings.

At first, the traces at the buildings are evaluated according to the comparative study in the building, nearby environment and written sources. After evaluation, the traces are categorized into four groups; Additions, Alterations, Removal and Original.

Secondly, depending on the results of the information coming from the historical research, comparative study and evaluation of clues coming from the building itself, the interventions made at the building are grouped. The facades, sections and plans of the building are drawn to present the facade organizations, architectural elements and plan scheme of the hamam during the restitution periods.

1.5.4 RESTORATION

Restoration project is the last stage of the thesis. This chapter consists, evaluations of the nearby environment and the building. Values, problems and potential evaluations are also done in this chapter.

The spaces are also evaluated in terms of areas of spaces, illumination quality and circulation layout.

As a result of this evaluations, general principles of the restoration project are estimated. The principles of the restoration project are defined in three categories; principles related to conservation, principles related to historical phases and principles related to new function. The types of interventions that are based on these restoration principles. Study is ended up with presentation of a restoration project.

CHAPTER 2

GENERAL FEATURES OF ÇUKUR HAMAM

2.1 LOCATION OF THE BUILDING

Birgi is located 9 km to Ödemiş, 41 km to Tire and 51 km to Salihli. Birgi can be reached overland from İzmir and by air from Adnan Menderes Airport which are 120 and 90 km away, respectively. (see Fig 2)

Çukur *Hamam* is situated at Okul street, the west border of the Camikebir Quarter which is connected to Fatih Mehmet Bey avenue.



Figure 6 Location of Birgi in Turkey Map.(Aegean region map is gathered as template from www.kgm.gov.tr)

2.2 THE NEARBY ENVIRONMENT OF THE BUILDING

Çukur Hamam is located in a medium dense area of Birgi and mostly surrounded by residential buildings. At north, just across Okul Street Derviş Aga Madrasa is situated.

Generally, the buildings around the Hamam are physically in good condition because of the rare alteration on their structure. Only a few numbers of traditional residential buildings are in bad condition.



Figure 7, Aerial Photograph of the Nearby Environment. (Google Earth, 2011)

2.3 GENERAL DESCRIPTION

Çukur *Hamam* is located at the north border of the main nucleus both at present and the Ottoman time which is at the south of Birgi around the market hall; on *Okul sokak* – a sloping street connecting the main streets of Birgi⁴².

⁴² Mine Hamamcioğlu, 1994, p 27

As the building is not in use and the condition of the building is bad. The floor is covered with earth and the *soğukluk* of the *hamam* was demolished, the superstructure of the *hamam* is highly damaged, domes of some of the spaces were demolished in time. In addition to this, Grass covered the roof and *tütekliks* had been demolished. The east facade of the building is used as a courtyard wall by the adjacent building and so the *Külhan* of the *Hamam* was demolished.

The ownership of the building is under the municipality of Birgi.

2.4 EXTERIOR DESCRIPTION

2.4.1 WEST FACADE

At present, the entrance of Çukur Hamam is from this facade. The Facade is approximately 3.80m in height and 13.04m in width. The wall construction technique of this facade is rubble stone masonry with brick fragments. The binding material is lime mortar.

The entrance is an arched door which is 6.13m from the left edge, while facing the wall, and 2.13m in height, 0.70m in width. This door is recessed from the wall surface within an arched niche with dimensions of 3.57m in height and 1.12m in width. This niche has a terracotta pipe between the spaces connected to this opening with a terra cotta pipe on the top of the arch.



Figure 8, West Facade of Çukur Hamam,

Moreover, there is also a rectangular canal going under the facade directly to the space z03 which is just 0.40m from the left corner of the wall while facing the wall. The dimensions of this canal are 0.13m in height and 0.40m in width.

The north corner of the wall which is also the west wall of the space z01 is highly damaged. There is severe area loss at the edge of this corner; the door of the courtyard of the neighbor building is installed to this corner. At the lower parts, approximately 1.19m below the datum line the sub-foundation of the adjacent building has come over the wall surface.

In addition to that the south west corner of the wall has collapsed This part starts in vertically from the datum line to the up left corner and the width of this collapsed area is 0.40m. The damage is also visible from the space Z03. There is a deep crack at the intersection of the south and west walls of the space.

2.4.2 THE SOUTH FACADE

The south facade of the hamam is measured 14.12m in width and 3.40m in height. But this facade consists two parts. The first one is 9.37m in width and ends with a collapsed wall which is perpendicular to this facade. The other part is 4.71m in width and starts with the collapsed part of the wall and ends with the arched opening of the water tank. There is an arched opening trace which was filled in time with dimensions 0.69m in width and 1.52m in height remained 3.63m from the right corner of the facade while facing the wall. The arched opening at the west part of the façade of the water tank is approximately 1.74m in height and 1.36 in width. The opening starts 0.24m from the southeast corner of the building. The south edge of the opening has been demolished. The construction technique of this facade differs in two parts depending on their binding material. The system is rubble stone masonry with brick fragments. At west, the binding material is lime mortar, but at the second part the binding material is mud mortar.



Figure 9, South Facade of Çukur Hamam

The south facade of the hamam is much more damaged than the west facade of the building. The corner of south facade and west facade is highly damaged. Starting 0.26m below the datum line to the top of the facade, the exterior face of it lost with a “v” shape in dimensions 0.17m at bottom and 1.18m at the widest point. Starting from the right corner, while facing, the wall the upper parts of the wall is also damaged. Rain water penetration caused material loss at these areas.

The infill material of the wall is exposed due to the plaster and mortar loss below the datum line 3.85m, 5.71 and 7.63m from the west wall. Moreover, the cause of these detachments and loss of mortar below the datum line can be rising damp.

Biological growth is also one of the major problems at this wall. At the top of the facade and the areas where the infill of the wall structure is visible grass came out of the wall surface. There is also a tree grown 1.53m above the datum line and 2.44m from the right edge of the facade while facing it.

The construction technique of this wall is rubble stone masonry with brick fragments. The binding material is lime mortar.

2.4.3 THE EAST FACADE

The south facade of the hamam measures 9.88m. The east wall and *Külhan* of the hamam is not visible. The courtyard of the adjacent building was constructed on the east facade. So any part of this facade could be documented during the site survey.



Figure 10, East Facade of Çukur Hamam

2.4.4 THE NORTH FACADE

The North facade of the building is measured 14.51m. The facade can be reached from the courtyard of the building at north. A toilet is constructed where Z04 space projects at the north facade.that part cannot be observed because of this. There is also a fireplace which is used as an oven constructed by using the wall surface. The empty areas are used as a dump area for unused material by them. The construction technique of this wall is rubble stone masonry with brick fragments. The binding material is lime mortar.



Figure 11, North Facade of Çukur Hamam

2.5 INTERIOR DESCRIPTION

2.5.1 SPACE Z01

Space Z01 which is 2.90m to 1.99m in size is located at the northeast corner of the building. It's entered through an arched door from Z02. At East, the space is adjacent to Z04, at south Z02. All the walls of this space are plastered with lime plaster.

The floor is covered with earth and because of the collapsed superstructure, the floor is now covered with debris.

The south wall of the space is 2.94m in height till to the top of the vault and 1.76m in width is the entrance wall where an arched door with 0.59m to 1.64m is located 0.65m from the west wall of the space. The surface of the wall is covered with lime plaster and from the deteriorated parts it is seen that the wall construction is rubble stone masonry with mud mortar as binding material. There are cracks and fissures on the wall. Also the demolition of the superstructure let the rain water penetrate in

and this has caused colour change and micro flora on the surface of the upper parts of the wall. In the mean time rising damp caused the detachment of the plaster at the lower parts of the wall.

The west wall of the space is 2.92 m in height till the top of the vault and 2.98 m in width. The surface is covered with lime plaster. The construction system is seen as rubble stone masonry with mud mortar as binding material. The upper level of the north part of the wall is collapsed and there is a deep crack between the north wall and the west wall at their corresponding point. Colour change and micro flora is seen on the surface of the wall due to the rain water penetration mostly at the areas close to the north wall. In addition to that; rising damp caused the detachment of the plaster at the lower parts of the wall.

The north wall of the space is approximately 2.09 m in height and 1.81 m in width. The upper part of this wall had been collapsed. In some parts of the wall lime plaster is seen. There is a deep crack at the intersection of west and north walls. The crack between east wall and north wall was filled with brick. The wall construction system is rubble stone masonry with brick fragments but there are some supplementary additions on this wall. These additions differ from the other part with the materials used and their workmanship. There are cracks and fissures on the wall. Micro flora is seen on the surface of the wall due to the rain water penetration. In addition to that; rising damp caused the detachment of the plaster at the lower parts of the wall.

The east wall of the space is 3.44 m in height till the top of the transition element and 2.92 m in width. The wall is covered with lime plaster. Due to the arch construction underneath the wall; the wall thickness differs from 0.40m to 0.61m. The arch starts 8 cm from the north wall and continues to the south wall. From the deteriorated parts, the construction system is seen as rubble stone masonry with mud mortar as binding material.

The superstructure of this space consist a dome and a vault at the same time. The entrance of the space is covered by a barrel vault with 1.07m width and 0.82m height from the springing line. The vault is covered with lime plaster and construction

material of the vault is Brick with 4cm*22cm*12cm dimensions with lime mortar. After the vault ends the space is turned approximately to square and pendentives are used as the transition elements for the domed superstructure. The dome has been demolished into the space, but then remained parts give enough information about the shape, construction system and material of it. Brick and lime mortar are the materials used for the construction of the dome. There are circular holes shaped by terra cotta pipes on the dome which remain 3m higher from the datum line.



Figure 12, Space Z01

2.5.2 SPACE Z02

Space Z02 which is 4.16m to 0.97m in size is the entrance space from the Okul Street. It is entered through an arched door from its west facade which is 2m in height and 0.71m in width. This space has connection with Z01 at north, Z03 at south and Z05 at east. Except the deteriorated parts all the walls of this space are covered with lime plaster. The floor covering is earth in this space.

The west wall of the space with 2.84m in height till the springing line of the vault and 4.13m in width has the arched door which is 2m in height and 0.71m in width placed 1.66m from the south wall. The surface of the wall is covered with lime plaster and from the deteriorated parts, it is seen that rubble stone and brick fragments used irregularly with mud mortar as binding material at the construction of this wall. Rising damp caused the detachment of the plaster at the lower parts of the wall. Because of the rain water penetration at the upper parts of the wall approximately 0.96m higher from the datum line change in colour and micro flora are easily seen.

The north wall of the space is 3.61m in height till the top of the vault and 1.04m in width. There is an arched door with dimensions of 0.59m to 1.81m on the wall 0.59m from the west which establishes the connection with Z01. Except the deteriorated parts all the walls of this space is covered with lime plaster. Rubble stone masonry with brick fragments are used for the construction system of this wall. At the upper parts of this wall approximately 0.91m above the datum line change in colour and micro flora is observed. There is also rising damp on the wall. The mortar between stones at the level of 0.23m below the datum line had detached because of the rising damp.

The east wall of the space is 2.82m in height till the springing line of the vault and 4.17m in width. There are two arched doors on this wall. They both establish the connection with Z05. The one starting from the lorth corner, is 1.94m in height and 0.75m in width and the other one which is 1.64m from the left corner, while facing the wall, is 2.05m in height and 0.66m in width. The wall is covered with lime

plaster and because of the deteriorations on the surface; some part of them detached irregularly. The construction technique of the wall is rubble stone masonry with brick fragments. The binding material of this wall construction is mud mortar. Rising damp caused detachment of the plaster at the lower parts of the wall. Because of the rain water penetration at the upper parts of the wall approximately 1.17m above the datum line change in color and micro flora are observed.

The south wall of the space with dimensions 3.62m in height till the top of the vault and 0.99m in width has an arched door which is 1.59m in height and 0.62m in width. The door is placed 0.19m from the west wall of the space. This arched door establishes the connection between Z02 and Z03. The surface of the wall is covered with lime plaster. The construction technique of the wall is rubble stone masonry with brick fragments. The binding material of this wall construction is mud mortar. The plaster has detached because of rising damp from the ground to 0.09m above the datum line. Moreover, rain water penetration at the upper parts of the wall, approximately 0.87m above the datum line; changes in colour and micro flora formation are easily seen.

The superstructure of this space is barrel vault and there are 4 circular holes for illumination which are shaped by using terra cotta pipes with approximately 0.21m diameter. Brick and lime mortar are used as main construction materials. From the surface, two dimensions of the brick units can be measured. (3cm*20cm). The surface of the vault is covered with lime plaster, but rain water penetration caused micro flora and change in colour on the surface of the plaster.



Figure 13, Space Z02

2.5.3 SPACE Z03

Space Z03 which has a rectangular shape with 3.05m to 1.40m is located at the southeast corner of the building. It's entered through an arched door from Z02. At East, the space is adjacent to Z06. The floor covering of this space is earth, but it's filled with earth deposit. There is a canal starting from the middle of the space continuing under the south wall of the space.

The north wall of the space with dimensions 3.64m in height and 1.42m in width has an arched door which is 1.68m in height and 0.63m in width. Despite the detached parts, the surface of the wall is covered with lime plaster. Brick fragments are used

irregularly at this rubble stone masonry wall and mud mortar is used as binding material. Rising damp has reached approximately 0.15m above the datum line. Loss of mortar is observed at the lower parts of the wall. The plaster remained above the datum line has change in colour and micro flora caused by rain water penetration.

The east wall of the space with dimensions 2.77m in height till the springing line of the vault and 3.05m in width is a blind wall. Brick fragments are used irregularly at this rubble stone masonry wall. Mud mortar is used as binding material. Rising damp which has reached 0.18m above the datum line caused the detachment of the plaster and loss of mortar at the lower parts of the wall. Rain water penetration caused micro flora and change in colour at the remained parts of the plaster above the datum line.

The south wall of the space with dimensions 3.61m in height till the top of the vault and 1.38m in width is also a blind wall. Brick fragments are used irregularly at this rubble stone masonry wall. Mud mortar is used as binding material. There is a rectangular hole with dimensions 0.28m to 0.04m placed 0.64m far from the east wall. The canal starting from the middle of the room continues from this rectangular hole to outside, but not visible from the outside of this wall. 1.25m from the datum line, the wall is starting to detach from the space. There is a gap starting approximately 1.25m above the datum line ending at the top of the vault. Rain water penetration caused the detachment of the plaster at the higher parts of the wall. Rising damp which has reached 0.35m above the datum line caused the detachment of the plaster and loss of mortar at the lower parts of the wall.

The west wall of the space with dimensions 2.74m in height till the springing line of the vault and 2.97m in width is a blind wall. The construction technique of the wall is rubble stone masonry with brick fragments. The binding material of this wall construction is mud mortar. Lime plaster is used as finishing material. Rain water penetration caused micro flora and change in colour at the remained parts of the plaster above the datum line. Rising damp caused the detachment of the plaster and loss of mortar underneath the datum line.

The superstructure of this space is vault and there are six circular holes for illumination on it. Brick and lime mortar are used as main construction material. But rubble stone is also used at the corners. Lime plaster was used as finishing material. From the surface only two dimensions of brick can be measured. (3cm thickness on the surface and 27cm thickness used in the dome). Rain water penetration caused micro flora on the surface and in the interior faces of illumination holes of the vault.

2.5.4 SPACE Z04

Space Z04 is approximately square in shape with dimensions 3.09m to 3.07m. It can be accessed both from Z05 and Z07. At east; the space is adjacent with Z07, at south with Z05 and at west with Z01. All the walls of this space are plastered with lime plaster. The floor covering had been removed, so it cannot be observed. The surface of the space is full of earth deposit approximately 1.53m below the datum line.

The south wall of the space with dimensions 4.48m in height till the top of the transition element and 3.08m in width has an arched door which is 1.87m in height and 0.57m in width and placed 0.21m away from the west wall. The surface of the wall is covered with lime plaster. The construction technique of the wall is rubble stone masonry with brick fragments. The binding material of this wall construction is mud mortar. The colour of the plaster changes 0.45m below the datum line to from white to pinker. Some of the plaster had been detached from ground to 0.98m below the datum line. Measuring from the east wall between 1.33m and 1.55m, there is a demolished part starting from ground to 0.65m below the datum line. A terra cotta pipe with 0.16m diameter is observed 0.28m inside the wall surface. This pipe was installed vertically from ground continuing to the superstructure. Micro flora formation is observed approximately 1.65m above the datum line. Cement plaster was used irregularly on the surface underneath the datum line. Rising damp which has reached 0.78m below the datum line caused the detachment of the plaster and loss of mortar at the lower parts of the wall.

The east wall of the space with dimensions 4.53m in height till the top of the transition element and 3.10m in width has an arched door which is 1.67m in height

and 0.57m in width. This opening which is on the right corner, while facing the wall, establishes the connection with Z07. 0.27m below the datum line the pinker plaster is seen until the ground. There is a circular hole with 3cm diameter; measuring from the north wall between 1.69m and 2.32m, the plaster detached from ground till 0.47m below the datum line. This deterioration continues vertically on the wall till 1.26m above the datum line.

A root of a tree is seen on the north edge of the deteriorated part of the wall. Rising damp which has reached 0.82m below the datum line caused the detachment of the plaster and loss of mortar at the lower parts of the wall. Micro flora is observed approximately 1.51m above the Datum line. Rain water penetrated from one of the lightening holes of the dome caused change in colour on the wall.

The north wall of the space with dimensions 4.57m in height till the top of the transition element and 3.06m in width is a blind wall. There is a circular hole with 3 cm diameter 1.72m away from the east wall and 0.50m below the datum line. Due to the loess of floor covering; *cehennemlik* section of the building can easily be seen. Cehennemlik starts 1.21cm below the datum line. The construction technique of the wall is rubble stone masonry with brick fragments. The binding material of this wall construction is mud mortar. 0.30m below the datum line the pinker plaster is seen till the ground. A hole with irregular shape has been opened through the wall which is 1.19m away from the west wall and nearly at the level of datum line. At the upper parts of the wall close to the transition element; micro flora is seen. There is also rising damp at the level of 0.74m below the datum line.

The west wall of the space with dimensions 4.56m in height (till the end of the transition element) and 3.10m in width is a blind wall. 0.21m below the datum line the pinker plaster is seen till the ground. Because of the fire or smoke inside the space change in colour is observed below the datum line. A vertical trace of a chimney starting from the ground ending with a hole on the dome is remained 1.15m away from the south wall.

Stalactites were used as transition elements in this space. Unfortunately the rain water penetrated from the lightening holes of the dome caused micro flora. At west wall the traces of the chimney divides the stalactite into two. From the detached parts of the plaster, brick fragments are seen.

The superstructure of this space is dome which is constructed on the stalactites. There are 31 illumination holes on the dome. Except the one at the centre of the dome, the others are all lined up in an order. All these holes are circular in shape and this shape was given to them with terra cotta pipes which have 1cm thicknesses. The construction material of the dome is Brick (4cm thickness on surface x30cm thickness inside the dome) and lime mortar. Loss of plaster is seen at the centre of the dome and at the lower levels of the dome micro flora is visible.



Figure 14, Space Z04

2.5.5 SPACE Z05

Space Z05 is 4.18m to 3.84m in dimensions. This space is adjacent to Z02 at west, Z06 at south, Z08 and Z07 at east and Z04 at north. Z05 has access from Z02, Z06, Z07, and Z08. There are two entrances from Z02. One of them is just linear to the entrance of z02 from outside and the other one is at the northeast corner of the space Z05. The floor is covered with earth deposit, but in some parts, the marble covering is partially visible. With a width of approximately 60cm slate was covered on the floor along the walls. The slate covers the canals of the *cehennemlik*. The middle parts of the floor are covered with earth.

All the walls of this space are plastered. Two kinds of plaster are visible. At the upper parts lime plaster and at the lower parts lime plaster and horasan plaster are seen together. At the level of approximately 0.69m below the datum line on south, east and north walls the plaster ends with a curve end. This is the trace of the *seki* in this space. Segmented tromp is used as transition element in this space and between dome and tromp there is cornice.

The west wall of the space is 4.52m in height till the top of the transition element and 4.16m in width has two arched doors which establish the connection from Z02. The one wall is located 1.76m from the south wall is 1.96m in height and 0.65m in width. There is an iron door frame on this door. The other arched door is adjacent to the north wall. The dimensions of it are 1.96m in height and 0.76m in width. The surface of this wall is covered with lime plaster and starting 0.27m above the datum line to the ground horasan plaster is seen underneath of the lime plaster. Rising damp caused the detachment of the plaster and loss of mortar approximately 0.13m below the datum line from the ground. The construction technique of the wall is rubble stone masonry with brick fragments. The binding material of this wall construction is mud mortar. This is seen from the deteriorated parts of the wall. There is a hole on the opening which has iron installations on it. This hole is 1.01m above the datum line and 2.0m from the south wall. Micro flora formation is seen at the corners and on the faces of the tromps. Loss of plaster is seen on the upper parts of tromp located at the south side of the wall. there is a hole opened formerly which caused change in

colour and rain water penetration on the surface of the west wall is measured 3.03m above the datum line and 1.53m from the south wall.

The north wall of the space with 4.58m in height till the top of the transition element and 3.79m in width has an arched door with dimensions 1.87m in height and 0.59m in width. This opening establishes the connection with z04. 1.06m over the datum line there is a door frame with 0.15m thickness. The construction technique of the wall is rubble stone masonry with brick fragments. The binding material of this wall construction is mud mortar. The surface of this wall is covered with lime plaster and starting from ground till 0.47m above the datum line horasan plaster is seen underneath the lime plaster. Loss of plaster is seen on the upper parts of tromps. Rising damp which has reached 0.43m below the datum line causes the detachment of the plaster and loss of mortar at the lower parts of the wall. Micro flora caused by the rain water coming from the illumination holes at the dome seen on both transition element and at the corners of the wall surface.

The east wall of the space is 4.55m in height till the top of the transition element and 4.17m in width and has two arched doors. The one starting from the north corner is 1.87m in height and 0.74m in width. This opening establishes the connection with Z07. The other one which is 2.37m from the north wall is 1.88m in height and 0.63m in width. This opening is recessed from the wall surface. The surface of this wall is covered with lime plaster and starting 0.32m above the datum line until the ground level horasan plaster is seen underneath the lime plaster. The construction technique of the wall is rubble stone masonry with brick fragments. The binding material of this wall construction is mud mortar. Micro flora caused by the rain water comes from the illumination holes at the dome seen on both transition element and at the upper parts of the surface. Loss of plaster is seen on surface of the wall. Rising damp which has reached 0.62m below the datum line caused the detachment of the plaster and loss of mortar at the lower parts of the wall.

The south wall of the space is 4.38m in height till the top of the transition element and 3.87m in width. It has an arched door with dimensions 1.80m in height and 0.72m in width. This opening is 2.61m from the east wall and establishes the

connection with z06. The surface of this wall is covered with lime plaster and starting 0.09m below the datum line to the ground horasan plaster is seen underneath the lime plaster. Rising damp which has reached 0.69m below the datum line caused the detachment of the plaster and loss of mortar at the lower parts of the wall.

The space is covered with dome and transition is provided by tromps. Micro flora caused by the rain water came from the illumination holes at the dome seen on both transition element and at the corners of the wall surface. There is change in color that was caused by the rain water coming from the illumination openings at the dome and there are also fissures on the surface of the wall.

2.5.6 SPACE Z06

Space Z06 has an approximately square shape and its dimensions are 3.36m to 3.40m. This space is adjacent to Z03 at west, Z09 at east and Z05 at north. The south wall of the space is also a part of the south facade. Z06 has access from Z05 and Z09. The superstructure of the space has been collapsed inside so the floor is covered with debris, but the floor covering is partially visible. The floor is covered with a width of approximately 40 cm slate along the walls. The slate covers the canals of the *cehennemlik*. The centre of the floor is covered with earth.

The north wall of the space is 2.78m in height till the starting point of the transition element (Turkish triangle) and 3.37m in width. It has an arched door with dimensions 1.92m in height and 0.72m in width. This opening is 0.10m from the west wall and establishes the connection with Z05. The construction system of the wall is rubble stone masonry with brick fragments. The binding material is mud mortar.. The surface of this wall is covered with lime plaster. At the upper levels because of the absence of the superstructure, rain water caused micro flora and detachment of the plaster. At lower levels, 1.20m below the datum line, rising damp has caused detachment of the plaster.

The east wall of the space with dimensions 2.77m in height till to the starting point of the transition element and 3.41m in width. There is an opening in an amorphous

form which is 0.16m from the south wall. The dimensions of the opening at the wider points are 2.15m in height and 1.22m in width. Two terra cotta pipes are seen 1.45m from the south wall and 0.11m below the datum line. These pipes are put horizontally and perpendicular to each other. The construction system of the wall is rubble stone masonry with brick fragments. The binding material is mud mortar.. Rising damp which has reached 0.37m below the datum line has caused the detachment of the plaster and loss of mortar at the lower parts of the wall. In addition to that, the plaster is also detached from the surface over the datum line close to the amorphous opening and the area close to the north wall of the space. Micro flora is visible at the right corner of the wall 0.61m above the datum line. Grass is observed on the Turkish triangles.

The south wall of the space with dimensions 2.70m in height till the starting point of the transition element and 3.39 m in width is a blank wall. The surface of this wall is covered with lime plaster and starting 0.22m below the datum line to the ground horasan plaster is visible underneath the lime plaster. The construction system of the wall is rubble stone masonry with brick fragments. The binding material is mud mortar at this wall. At the upper levels because of the absence of the superstructure, rain water caused micro flora and detachment of the plaster and grass is observed at the top of the wall. At lower levels, 1. 08m below the datum line, rising damp caused the detachment of the plaster.

The west wall of the space with dimensions 2.72m in height till the starting point of the transition element and 3.40m in width is a blank wall. The surface of this wall is covered with lime plaster but deteriorations such as rain water penetration and rising damp caused detachment on most of the wall surface. At the remaining parts micro flora is observed. The construction system of the wall is rubble stone masonry with brick fragments. The binding material is mud mortar at this wall. 0.83m from the datum line and 1.73m from the north wall, *tüteklik* of is seen because of the material loss on the wall at that part. Below the datum line horasan plaster is also seen.

The superstructure of the space was dome according to the traces, but in time the dome was collapsed. The transition element of the space is Turkish triangles. The

construction elements of both transition element and dome are brick and lime mortar. The surface of the dome is not known but transition element is covered with lime mortar.

2.5.7 SPACE Z07

Space Z07 which has an approximately square shape is 3.94m to 3.98m in dimensions. This space is adjacent to Z04 and Z05 at west, Z08 at south, Z10 at east and the north wall of the space is a part of the north facade. Z07 has access from Z04, Z05, Z08 and Z10. The floor is covered with earth deposit, but the floor covering is partially visible. With a width of approximately 65cm slate is covered along the walls. The slate covers the canals of *cehennemlik Seki* is partially remained along the north, east and south walls of this space. The north-west corner of the floor has been removed and the canalled system of *cehennemlik* is visible.

All the walls of this space are plastered. Two kinds of plaster are visible. At the upper parts lime plaster and at the lower parts lime plaster and horasan plaster are seen together. Turkish triangle is used as transition element in this space and between dome and tromp there are cornice of 3 strips.

The west wall of the space is 3.57m in height till the top of the transition element and 4.04m in width. There are two arched doors establishing connection with two different spaces. The one adjacent to the south wall is entered through Z04 and has dimensions with 1.81m in height, 0.71m in width. The other door establishing the connection with Z05 is 1.66m in height and 0.55m in width in dimensions and it is 1.46m far from the south wall. Because of the lack of the floor covering at the north corner of the wall, the starting point of the floor and thickness of it can be determined. The wall surface is covered with plaster. Two different kinds of plasters are visible. From the ground till 0.09m below the datum line, a grayish coloured plaster is above all layers of plaster. Underneath of it horasan plaster is seen. Horasan plaster is visible at the cracked and detached parts above the datum line. Also lime plaster is the finishing material at the surface of the wall above the datum line. Approximately 2.35m from the south wall, there is material loss vertically along the

wall. This may be happened because of vandalism. From this deteriorated area, the construction technique of the wall is easily seen. The construction technique is rubble stone masonry with brick fragments. The binding material of this wall construction is mud mortar. There are cracks and fissures on the surface of the wall. The only structural crack starts from the corner of the arched door approximately at the middle of the wall, continues vertically to the top of the transition element. There is micro flora at the starting points of the transition element and on the faces of the Turkish triangles.

The north wall of the space with dimensions 3.60m in height till the top of the transition element and 3.94m in width is a blind wall. The wall surface is covered with plaster. Two kinds of plasters are observed. From the ground till 0.15m above the datum line, grayish lime plaster is seen above the surface. From the deteriorated parts horasan plaster is visible. This plaster continues to the starting point of the transition element. After the grayish lime plaster finishes on the surface, lime plaster continues to the top of the dome. There is a circular water pipe with 3cm diameter coming through the wall. This is the water source of the *kurna* adjacent to this wall.

There is change in colour which was caused by the rain water came from the illumination opening at the dome and there are also fissures on the surface of the wall. Most of the fissures are around the deteriorated part of the wall. By means of deterioration, there is material loss starting 0.96m above the datum line and continuing till 1.40m from the datum line vertically. Horizontally, the loss starts at the point 0.50m from the east wall and continues till 1.49m from the east wall. From that area, the construction technique of the wall is easily seen. The wall is rubble stone masonry with brick fragments. The binding material of this wall construction is mud mortar.

The east wall of the space which is 3.63m in height till the top of the transition element and 4.01 in width has an arched window. This window starts 0.57m from south wall and 0.35m above the datum line. This window is also called as *taşma penceresi* which establishes the connection with Z10 (water tank). If the water in the tank exceeds the capacity; water is released from this window. The window is 0.82m

in height and 0.66m in width. The wall surface of this space is covered with plaster. Two kinds of plasters are observed. From the ground till 0.12m above the datum line, grayish lime plaster is above the surface. From ground approximately till 0.18m below the datum line, the infill of the wall structure is visible. At these parts the finishing and the surface of the wall detached from the wall structure. From the deteriorated parts horasan plaster is seen underneath. At the point that the grayish coloured lime plaster finishes whiter lime plaster continues till the top of the dome. The pipe system is visible at this wall. Terra cotta pipes are going horizontally 0.52m below the datum line. The place of *kurna* can be determined from the circular opening on the pipe which is located 0.48m below the datum line and 1.43m away from the south wall. There is micro flora that was caused by the rain water came from the illumination holes at the dome seen on both transition elements and the wall surface.

The south wall of the space which is 3.49m in height till the top of the transition element and 3.97m in width is the most damaged wall of hamam. There is an arched door located 0.66m from the west corner of the wall. The demolition at this wall starts from the middle of the door continues approximately 1.60m in horizontal and 2.83m vertically from ground to the highest point. At this point *tüteklik* is seen clearly from the demolished part continuing vertically in the wall. The wall surface is covered with plaster. Two kinds of plaster are observed. From the ground till 0.13m above the datum line, grayish lime plaster is above the surface. At the point where the grayish plaster finishes on the surface; lime plaster continues to the top of the dome. Underneath of them horasan plaster is visible but the height of it cannot be determined. The construction technique of the wall is rubble stone masonry with brick fragments. The binding material of this wall construction is mud mortar. Micro flora caused by the rain water came from the illumination holes at the dome seen on both transition element and at the corners of the wall surface.

The space is covered with dome. The transition element is Turkish triangles. Apart from the known visual appearance, the edges of triangles are nonlinear. There are twenty-five illumination holes on the dome. All these holes are circular shaped and this shape was given to them with terra cotta pipes which have approximately 1cm

thickness. The construction material of the dome is brick (4cm thickness on the surface x 30cm thickness within the dome) and the thickness of the brick is constant at all heights. The binding material is lime mortar. Loss of plaster is seen at different levels of the dome. Unfortunately the rain water penetrated from the lightening holes of the dome has caused micro flora on the surface and change in colour near the illumination holes.

2.5.8 SPACE Z08

Space Z08 is 3.94m to 3.98m in dimensions and adjacent to Z05 and Z06 at west, Z09 at south, Z10 at east and Z07 at north. Z08 has access from Z05, Z07, Z09. The floor is covered with earth deposit, but the original covering is partially visible at northeast corner. The floor covering is slate with a width of approximately 0.75m. Slates are covering the canals of the *cehennemlik*. *Seki* is partially remained along the north, east and south walls of this space. The centre of the floor is covered by earth.

The west wall of the space with dimensions 4.04m in height till the top of the transition element and 3.82m in width has an arched door. This door is 1.84m in height, 0.61m in width and 0.83m from the north wall of the space. The wall surface is covered with plaster. Two different kinds of plasters are visible. From the ground till 0.26m below the datum line; a grayish coloured plaster is above all layers of the plaster. Underneath of it horasan plaster is seen. This horasan plaster is visible at a level of 0.25m above the datum line. Also lime plaster is the finishing material at the surface of the wall till the top of the dome. Starting 0.14m from the left side of the door, the surface has been demolished and the infill of the wall is visible till 0.10m above the datum line. From this part, the construction system of the wall is determined as rubble stone masonry with brick fragments; and the binding material is mud mortar. *Tüteklik* is visible at this wall. It is located 1.86m from the north wall within a depth of 0.27m in the wall structure. The diameter of the terra cotta pipe of *tüteklik* is 0.12m. Micro flora caused by the rain water came from the illumination holes at the dome seen both on the transition elements and at the corners of the wall surface.

The north wall of the space is 4.06m in height till the top of the transition element and 3.84m in width. There is an arched door located 0.68m from the west wall of the space. The demolition at this wall starts from the half of the door continues approximately 1.65m in horizontal and 2.10m vertically from ground to the highest point. At this point *tüteklik* is seen clearly from the demolished part continuing vertically in the wall. The construction technique of the wall is rubble stone masonry with brick fragments, and the binding material is mud mortar. The wall surface is covered with plaster. Three kinds of plaster are observed. From the ground till 0.18m above the datum line, grayish lime plaster is above the surface. The grayish plaster finishes on the surface whiter lime plaster continues to the top of the dome. Underneath them horasan plaster is visible and this plaster continues from ground till 0.07m below the datum line. Micro flora caused by the rain water came from the illumination holes at the dome is seen both on transition elements and at the corners of the wall surface.

The east wall of the space which is 4.05m in height till the top of the transition elements and 3.84m in width is a blind wall. The wall surface is covered with plaster. Two kinds of plaster are observed. Starting from the ground till 0.19m above the datum line, grayish lime plaster is above the surface. The construction technique of the wall is rubble stone masonry with brick fragments. The binding material of this wall construction is mud mortar. From the datum line approximately between 0.51m and 0.19m the infill of wall structure is visible. Terra cotta pipes which are seen at these damaged parts are going horizontally 0.48m below the datum line. Two rows of pipes are observed continuing 0.12m below the wall structure. From the deteriorated parts horasan plaster is seen underneath the grayish lime plaster. At the point that the grayish coloured lime plaster finishes; whiter lime plaster continues till the top of the dome. There is micro flora which was caused by the rain water comes from the illumination holes at the dome seen on both transition element and the wall surface.

The south wall of the space is 4.08m in height till the top of the transition element and 3.91m in width. There is a niche 0.38m from the east which has a depth of 0.30m. The dimension of this niche is 1.08m in height, 0.66m in width. There is also a demolished part starting from 0.21m from the west wall of the space. The

demolished part doesn't have a geometric shape, but the closest part to west part is likely to be the half of an arched door. The demolished part continues on the wall surface at left with a decreasing ratio.

The wall surface is covered with plaster except the deteriorated parts. Three kinds of plaster are observed. From the ground till 0.06m above the datum line, grayish lime plaster is seen above the surface. At that level grayish plaster ends on the surface, whiter lime plaster continues to the top of the dome. Underneath them horasan plaster is visible and this plaster continues from ground till 0.17m above the datum line. The construction technique of the wall is rubble stone masonry with brick fragments. The binding material of this wall construction is mud mortar.

The space is covered with dome and transition is provided by turkish triangles. Micro flora caused by the rain water coming from the illumination holes at the dome seen both on transition elements and at the wall surface. There is also rising damp on the wall. The mortar between stones at the level of 0.74m below the datum line has been detached because of the rising damp.

2.5.9 SPACE Z09

Space Z09 is 2.29m to 1.88m in dimensions. This space is adjacent to Z11 at west, Z06 at east and Z08 at north. The south wall of the space is also a part of the south facade. Z09 has access from Z06 and Z08. The superstructure of the space has been collapsed inside so the floor is covered with debris, and the floor covering isn't visible.

The north wall of the space is 3.31m in height till the top of the transition element and 2.29m in width. There is a big hole on the wall with dimensions at the widest part 2.12m in height and 1.20m in width where the door has been remained before the demolition. In addition to that, the location of the door can be determined by the traces. At bottom from ground till 0.57m below the datum line and 0.44m from the west wall, the west side of the door remained. Although the wall has been plastered, at present; there is plaster only at bottom, at the area close to the transition

elements at west while facing the wall. Two kinds of plaster are observed. Below the datum line, horasan plaster is above the surface at east. At the area close to transition element at west, lime plaster continues to the top of the transition element. The construction technique of the wall is rubble stone masonry with brick fragments. The binding material of this wall construction is mud mortar. Because of the absence of the superstructure, rain water caused micro flora and detachment of the plaster. There is also rising damp on the wall surface. The mortar between stones at the level of 0.37m below the datum line has been detached because of the rising damp.

The east wall of the space is 3.23m in height till the top of the transition element and 2.39m. The wall has connection with Z11 with the opening adjacent to the south wall. The opening is 2.92m in height and 0.51m in width. There is a trace of an arch starting 0.51m above the datum line. The absence of superstructure caused rain water penetration and at the intersection areas of the flooring and the wall, grass growth is also observed. Rising damp is seen at the lower parts of the wall. The mortar between stones at the level of 0.39m below the datum line has been detached because of the rising damp.

In addition to that; over the transition elements micro flora is observed. Two kinds of plaster are observed. Below the datum line, horasan plaster is seen on the surface. At the area close to transition element, lime plaster continues to the top of the transition element. The construction technique of the wall is rubble stone masonry with brick fragments. The binding material of this wall construction is mud mortar.

The south wall of the space with dimensions 3.29m in height till the top of the transition element and 1.90m in width is a blank wall. The absence of superstructure caused rain water penetration and so at the intersection areas of the flooring and the wall grass growth is seen. There is also rising damp on the wall surface. The mortar between stones at the level of 0.41m below the datum line has been detached because of the rising damp. At the upper areas and on the transition elements; micro flora is observed. Plaster is seen on the wall at the upper areas but it does not continue until the floor level. At the lower parts below the datum line; there are no signs of plaster.

The construction technique of the wall is rubble stone masonry with brick fragments. The binding material of this wall construction is mud mortar.

The west wall of the space is 3.31m in height till the top of the transition element and 2.29m in width. This wall establishes connection with Z06 by the demolition on the wall with dimensions of 2.12m in height and 1.20m in width at the widest points. Terra cotta pipes are visible at both sides of the infill of the wall at the demolished area. There is also a canal going under the opening shaped by stones. The absence of superstructure caused rain water penetration and so at the intersection areas of the flooring and the wall, grass growth is seen. Moreover micro flora is observed on the transition elements.

The wall surface was formerly plastered and two kinds of plasters are observed. Below the datum line, horasan plaster is seen on the surface. At the area close to the transition element, lime plaster continues to the top of the transition element. The construction technique of the wall is rubble stone masonry with brick fragments. The binding material of this wall construction is mud mortar.

2.5.10 SPACE Z10

Space Z10 is the water tank of the *hamam*. The dimensions of the space are 8.64m to 2.36m and adjacent to Z07 and Z08 at west and at the other directions the walls maintains the borders of the *hamam*. This space can be entered through a window from Z08 and the collapsed arched wall at south. The floor is partially visible. The horasan plaster on the walls continues on the floor. There is also a circular hole with diameter of 1.21m exists at the middle of floor. This hole is a part of heating system of the hamam. The fire burns at the bottom of this hole. The superstructure of the space is a barrel vault.

The south wall of the space has mostly been collapsed but the dimensions of the surface can be given as 2.43m in height and 2.19m in width. The remained part in horizontal is measured approximately 0.87m at right. The wall surface was formerly plastered but now there is only plaster remained below the datum line and a small

part at up west corner. The type of the plaster is the same at all heights, which is horasan plaster; but the thickness differs according to the height. The plaster below the datum line is thicker than the ones at the upper parts. The construction technique of the wall is rubble stone masonry with brick fragments. The binding material of this wall construction is mud mortar.

The west wall of the space with dimensions 2.38m till the top of the vault and 8.74m in width has an arched window. This window is 0.31m above the datum line, 2.63 from the north wall of the space and measures 0.81m in height and 0.73m in width. 1.76m from the south wall and 0.49m from the datum line, terra cotta pipes are visible at the surface. There are four pipes lined up. At the bottom of the window there is a circular hole going through the wall adjacent to ground. The wall surface was formerly plastered but now the plaster has remained partially. The type of the plaster is horasan plaster, but the thickness of the plaster differs according to the height. The plaster below the datum line is thicker than the ones at the upper parts. The construction technique of the wall is rubble stone masonry with brick fragments. The binding material of this wall construction is mud mortar.

The north wall of the space is 2.42m in height till the top of the vault and 2.18m in width. This wall is a blind wall, but starting from 0.59m from the datum line till the top of the vault has been demolished. This demolished area was covered with lumber, galvanized sheet and straw. The wall surface is plastered. The type of plaster is horasan plaster. The construction technique of the wall is rubble stone masonry with brick fragments. The binding material of this wall construction is mud mortar.

The east wall of the space with dimensions 2.40m in height till the top of the vault is a blind wall. The wall surface has been fully plastered, but in time plaster is only visible approximately under a level of 0.48m above the datum line. At these areas, only a thicker horasan plaster is observed. The construction technique of the wall is rubble stone masonry with brick fragments. The binding material of this wall construction is mud mortar.

The superstructure of this space is barrel vault. The construction technique is the similar with the walls. The binding material is lime mortar. The plaster on the vault is

mostly detached, but lime plaster is visible at small parts of the vault. There are some important structural cracks on the vault. The most important damage on the vault is the crack that continues at south-north direction on the top of the vault one of which also detached the structure of the vault into two.

2.5.11 SPACE Z11

Space Z11 has two walls remained. The south and east walls has been collapsed in time. Z11 can be reached both from outside and inside through Z09. The floor covering is not visible. It is full of debris. The space is adjacent to Z09 at west, Z08 and Z10 at north. There is a *seki* adjacent to north wall with a width of 0.48m in this space. The height of this *seki* is 0.46m.

The west wall of the space has dimensions of 3.98m in height and 3.69m in width. The wall has connection with Z11 with an opening. It is 2.92m in height and 0.51m in width. There is a trace of an arch starting 0.51m above the datum line. The absence of superstructure caused rain water penetration and so the surface of the wall has been covered with micro flora and grass. The plaster on it has also been detached because of the same reason. At the bottom, horasan plaster is visible; and at upper areas lime plaster is seen. The separation of the level of these two plasters is not certain due to the damaged parts. There is also some grass on the top of the wall. The construction technique of the wall is rubble stone masonry with brick fragments and the binding material is mud mortar.

The north wall of the space is a blind wall with dimensions 4.16m in height and 3.05m in width. There is a trace of an arched door on the surface. The *seki* adjacent to this wall starts 0.13m after the arched door trace. A terra cotta pipe is visible on the wall surface the pipe has been remained in the wall edge bedded 0.16m below the datum line adjacent to the west wall. The wall surface and structure is highly damaged. Two kinds of plaster are seen on the wall surface. Due to the deteriorations some of them have been detached, but horasan plaster and lime plaster is visible on the surface.

The tree coming through the wall is located 1.51m above the datum line and 2.27m from the west wall. There are severe structural cracks around this tree.

At up left corner some parts of transition element have been remained. The starting point of the tromp is visible at this point.

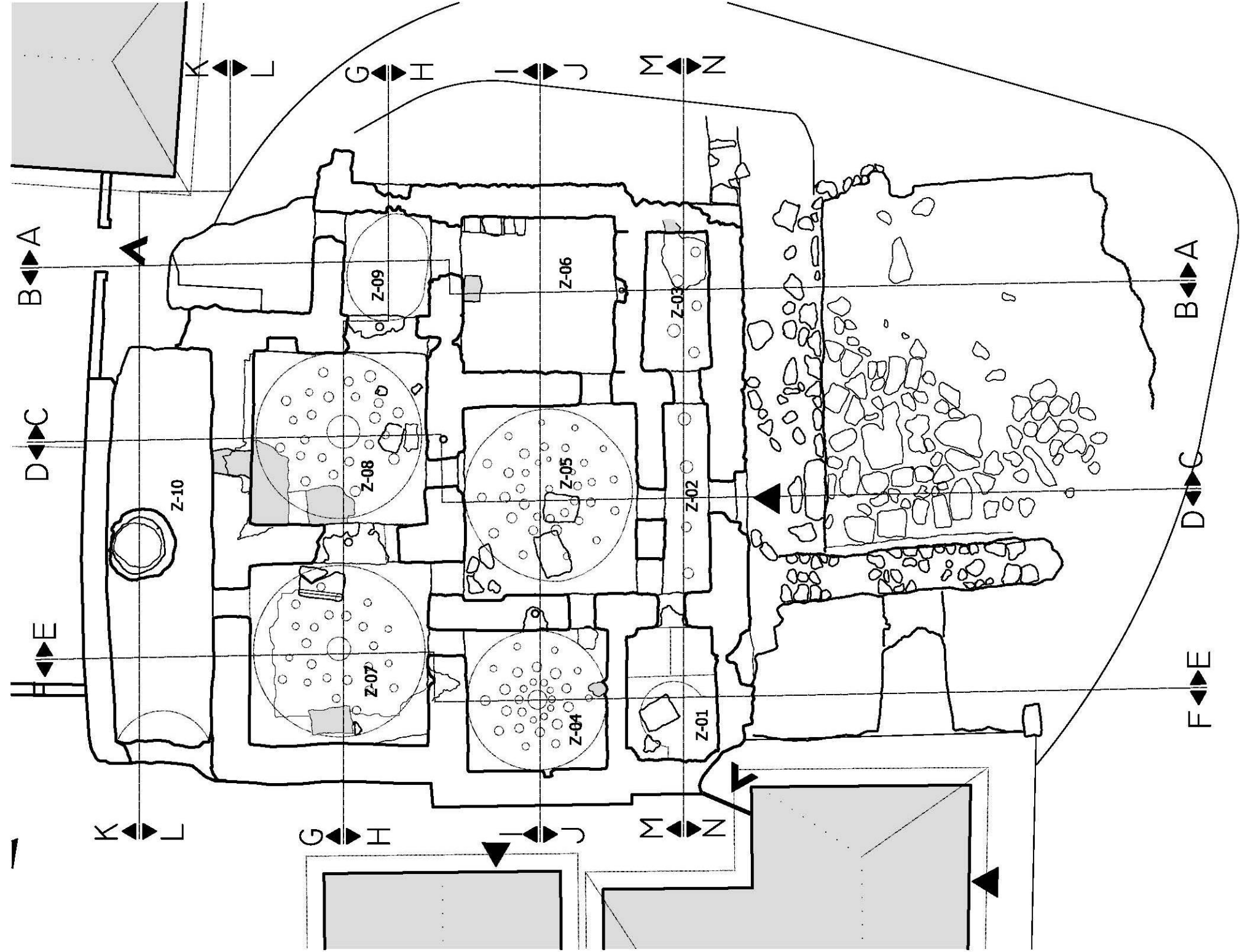


Figure 15, Measured Drawing, Plan

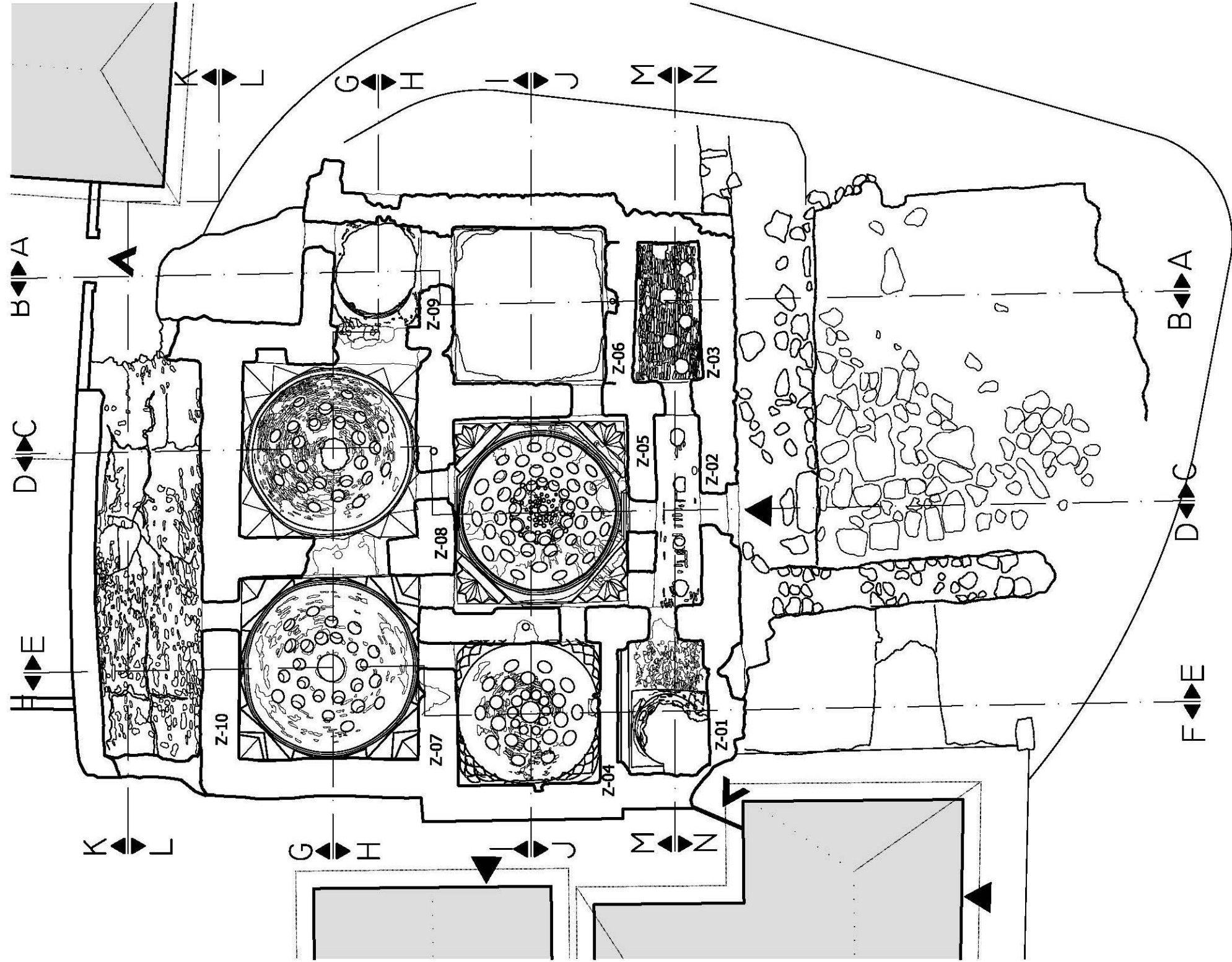


Figure 16. Measured Drawings, Ceiling Plan

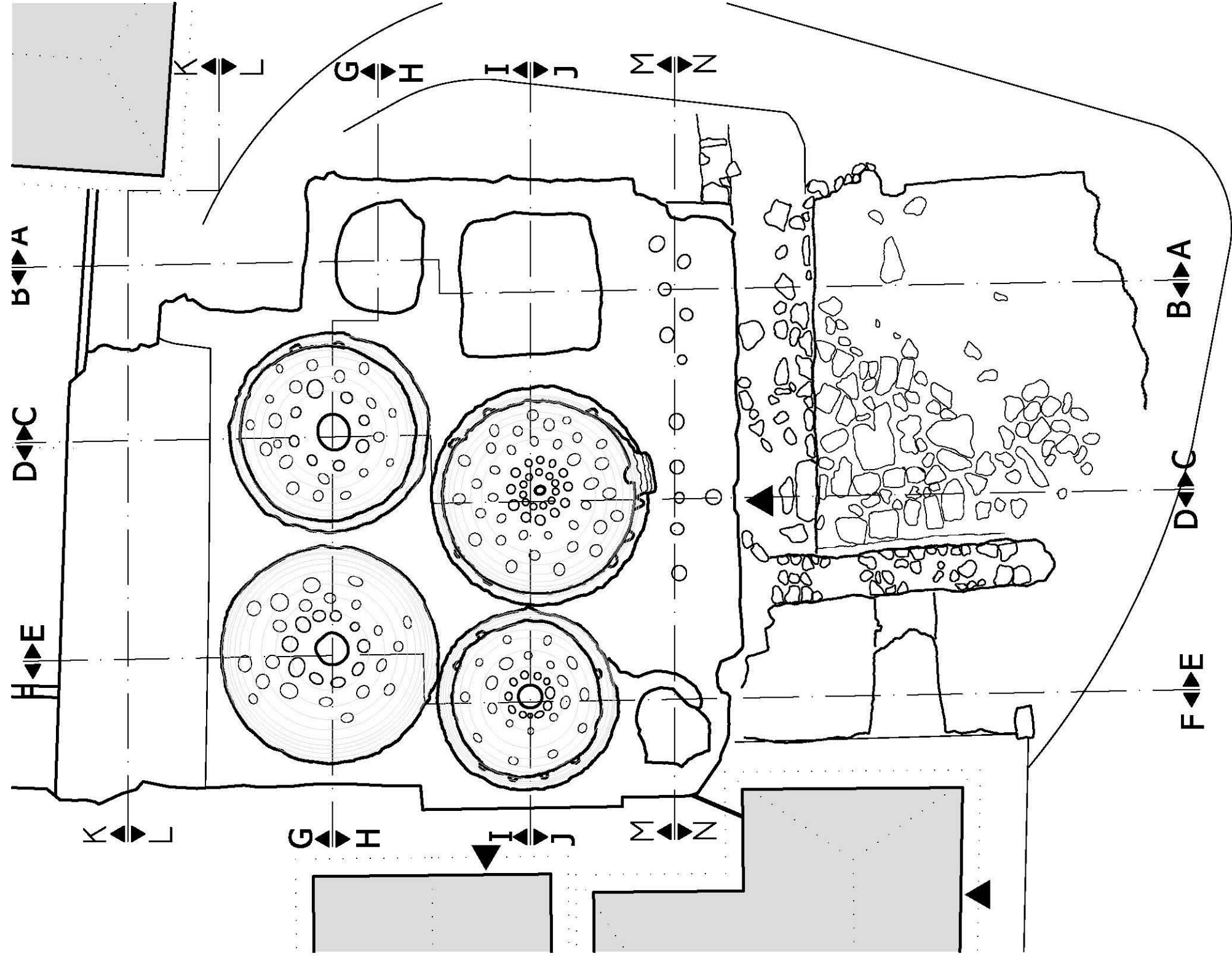


Figure 17, Measured Drawings, Roof Plan

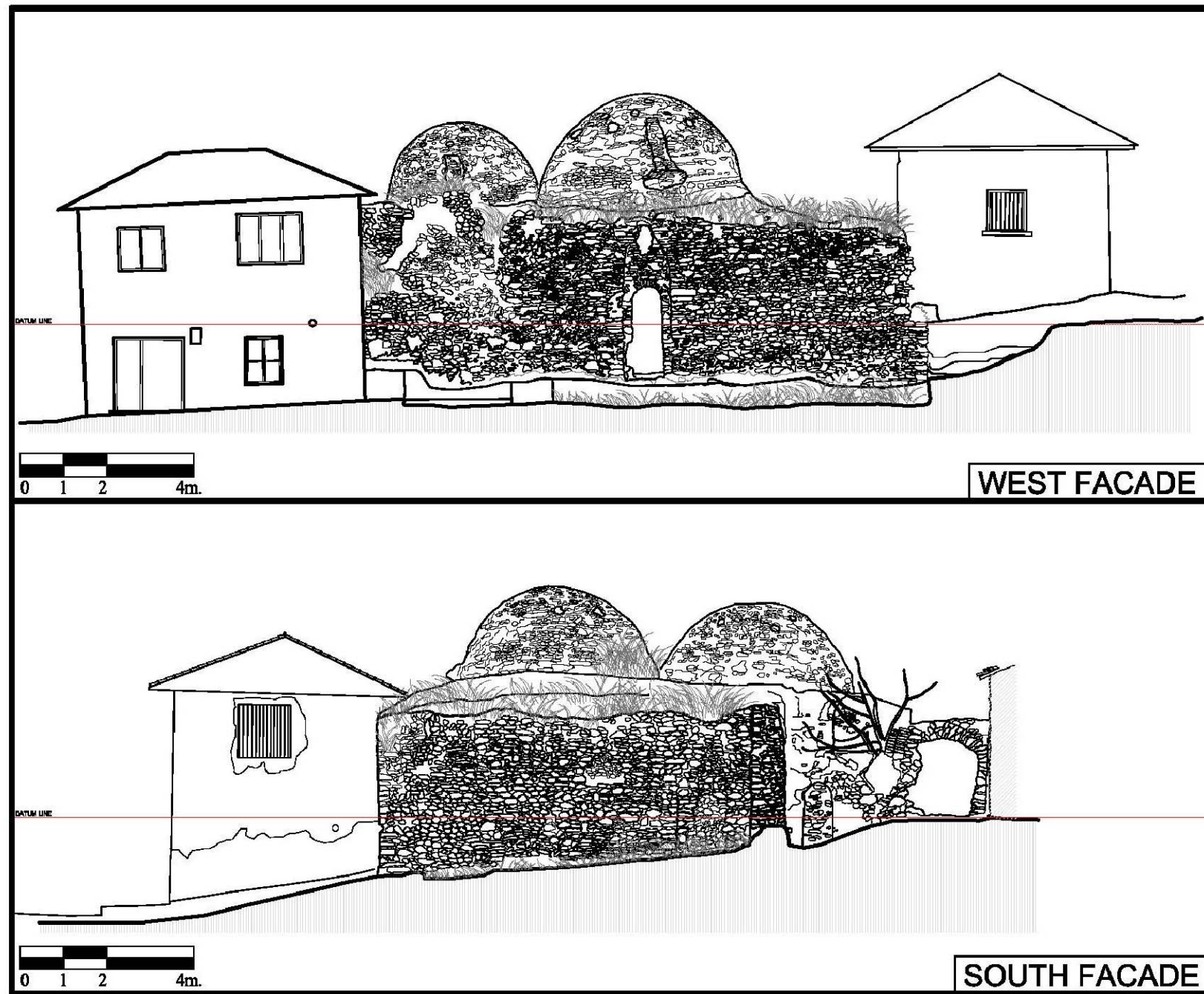


Figure 18, Measured Drawings, Facades

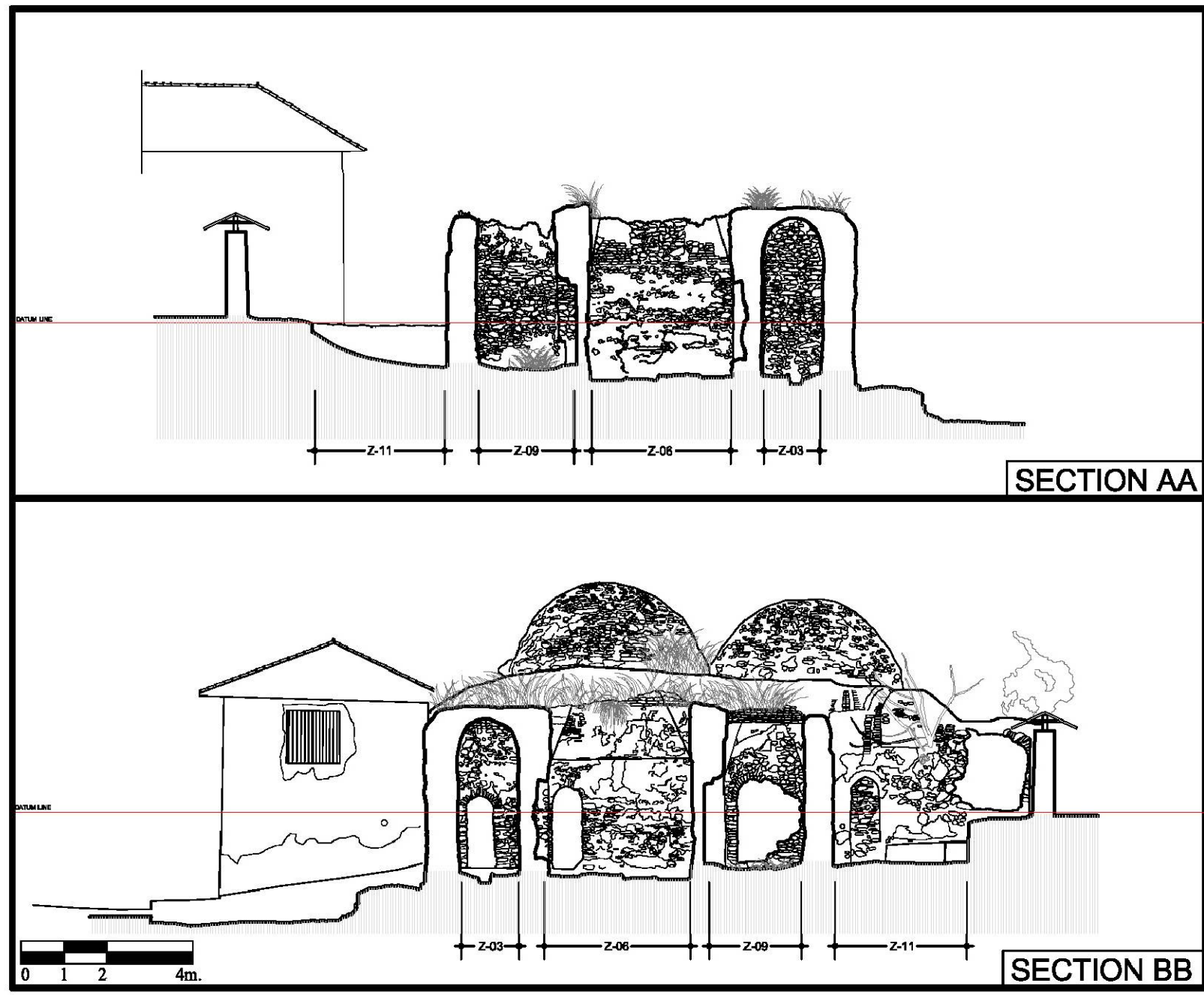


Figure 19, Measured Drawings, Section AA and BB

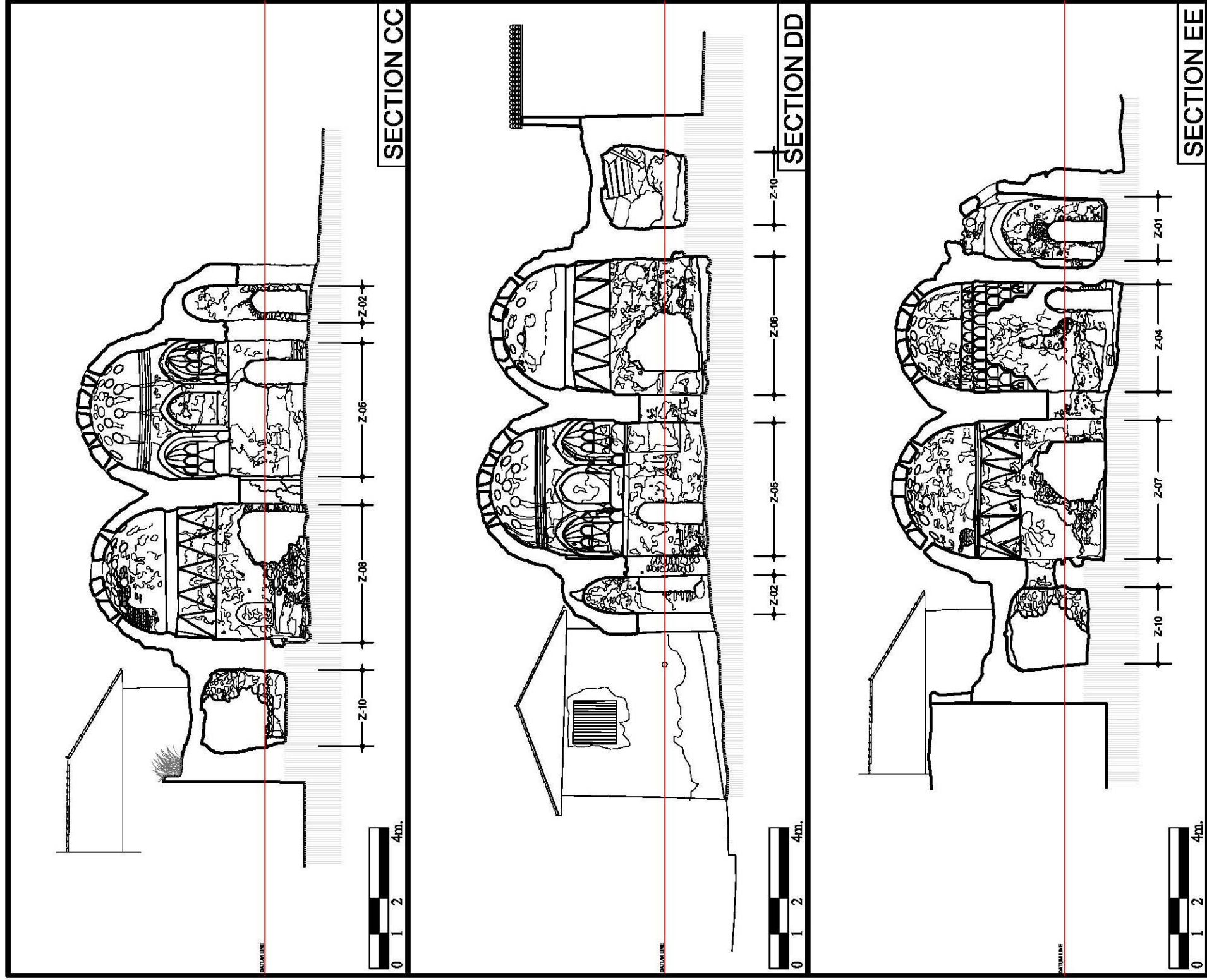


Figure 20, Measured Drawings, Section CC, DD, EE

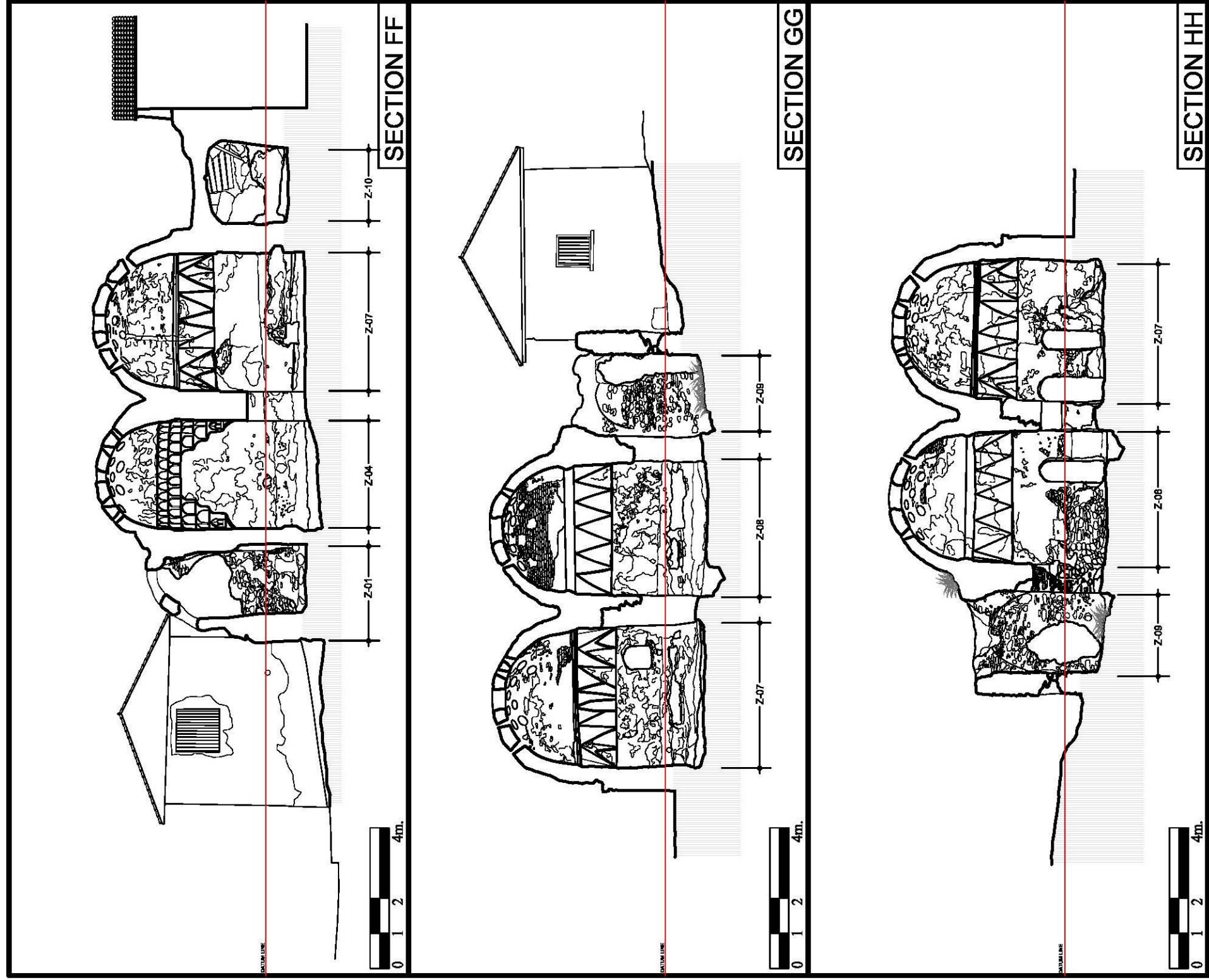


Figure 21, Measured Drawings, Section FF, GG, HH

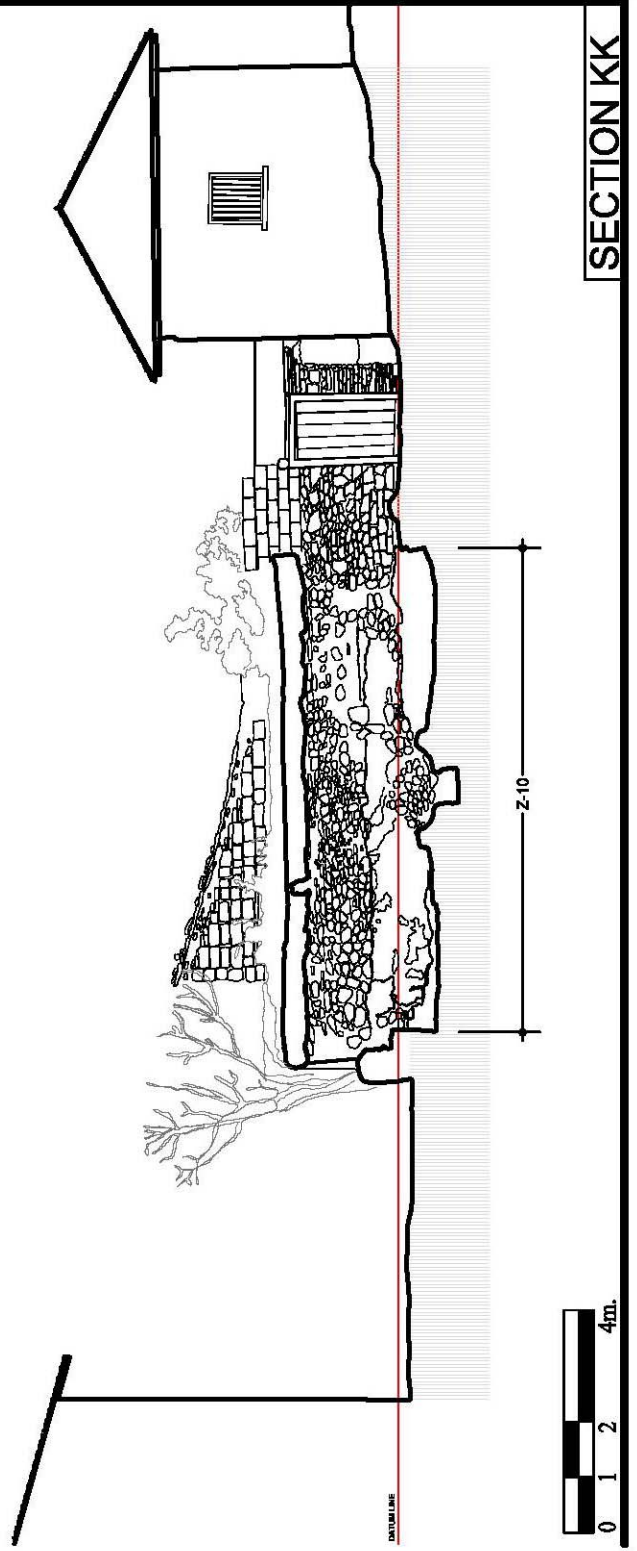
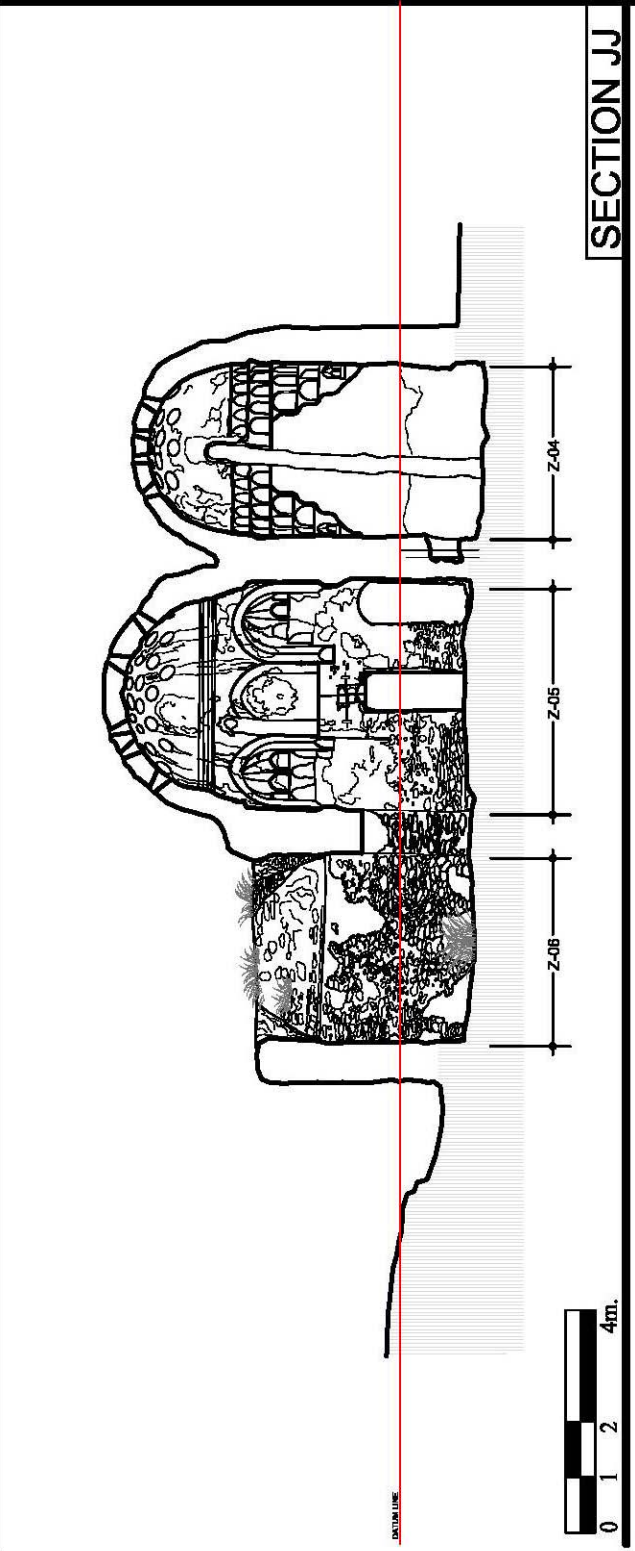
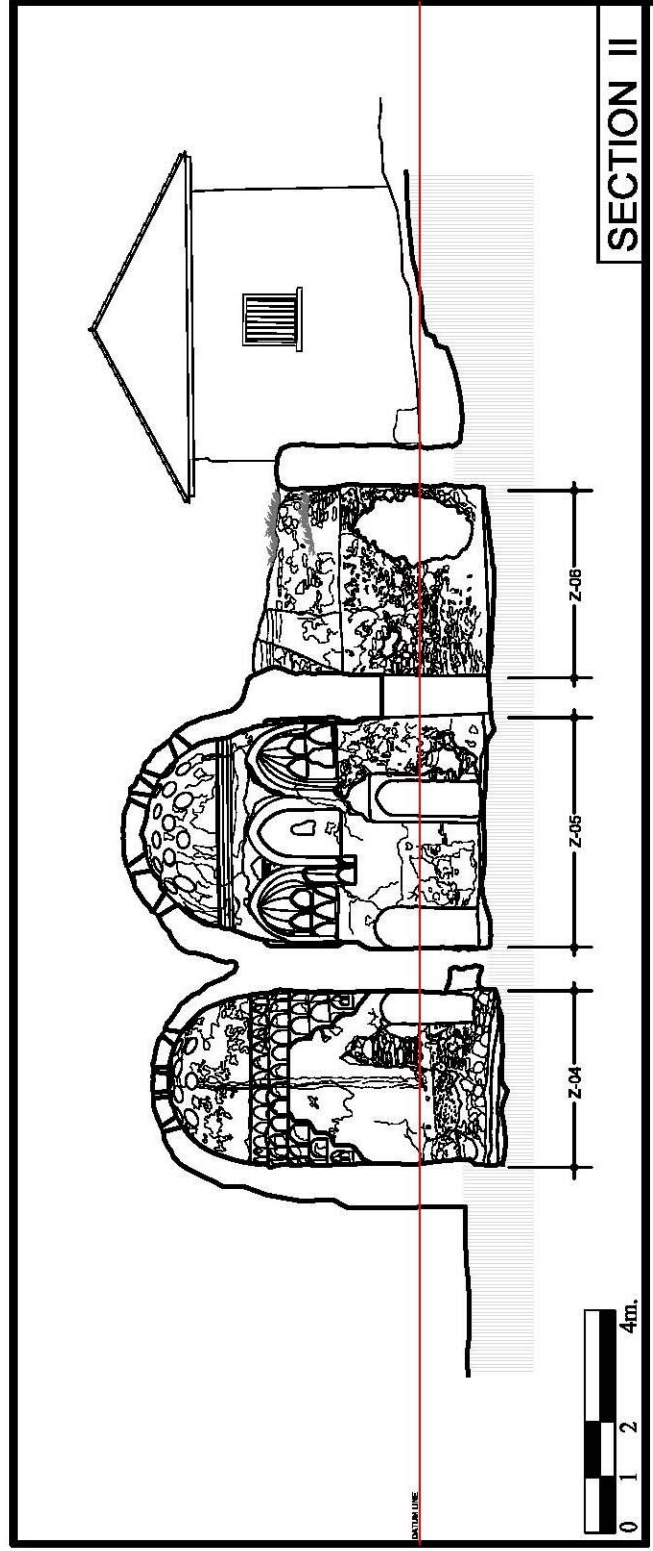


Figure 22, Measured Drawings, Section II, JI, KK

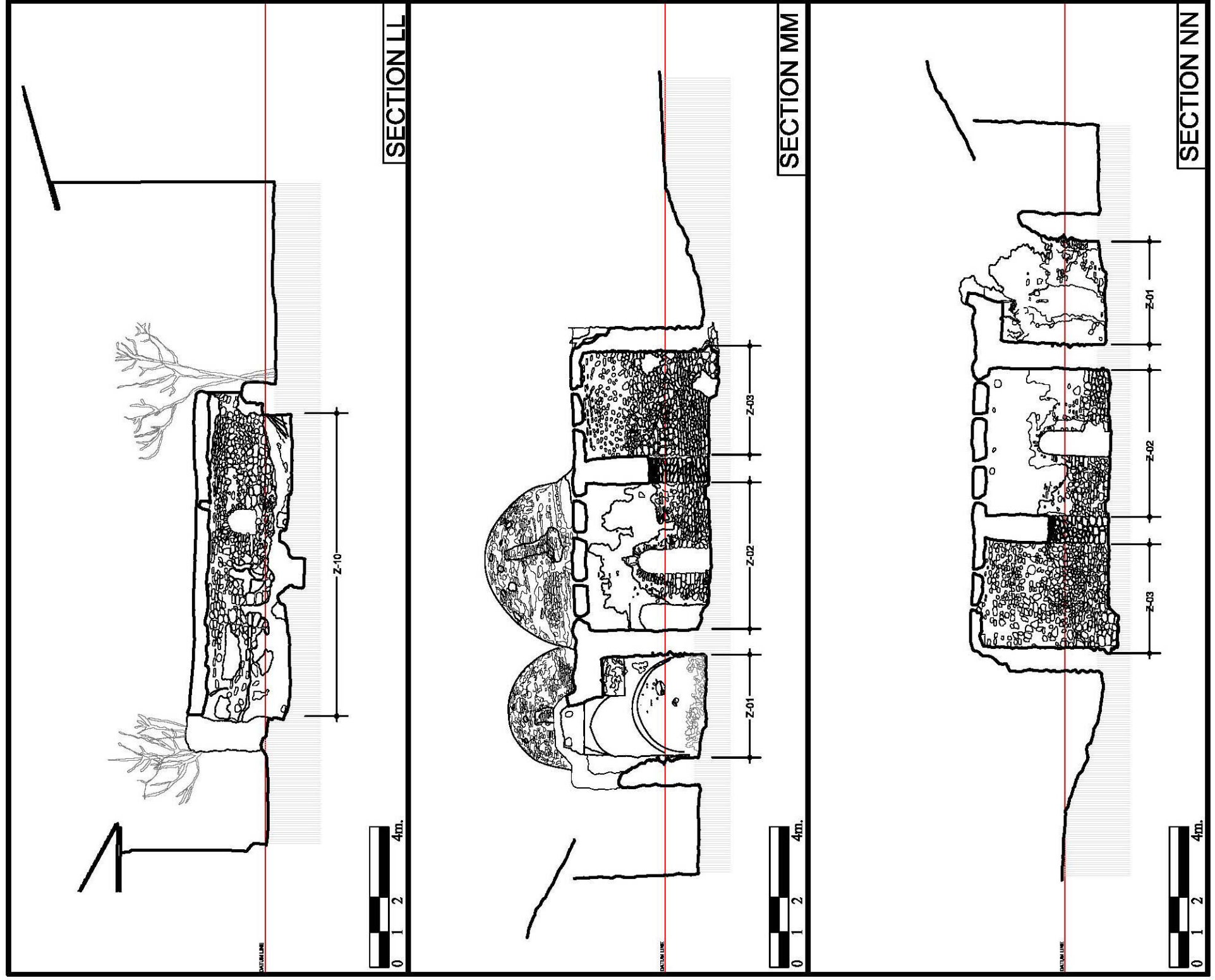


Figure 23, Measured Drawings, Section LL, MM, NN

2.6 ARCHITECTURAL ELEMENTS

2.6.1 DOORS

There are two main types of doors observed in Çukur Hamam. This classification is made according to the form and construction technique of the doors (Table 1).

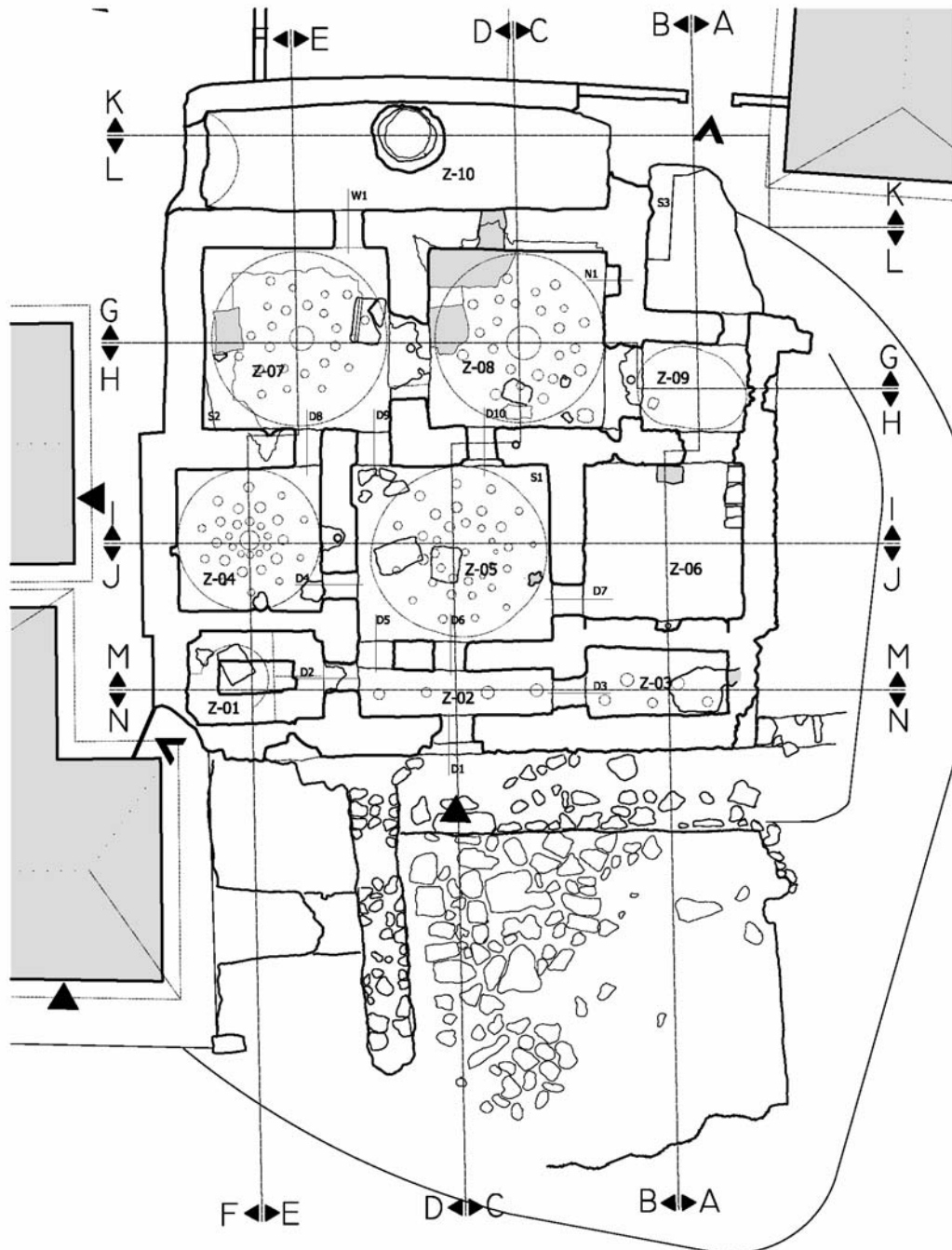





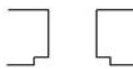





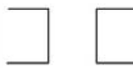


Figure 24, Distribution of Architectural Elements

The first type coded DT1 is semi-circular arched door. This door type is seen at Z01 (D2), Z03 (D3), Z04 (D4), Z05 (D6), Z06 (D7) and Z08 (D9). The width of this door type differs from space to space between 0.60m to 0.72m. Below the springing line, the construction material is stone and at some of the examples brick fragments are observed. Mud mortar is used as binding material. Above the springing line, the arch shape is given by bricks. Lime mortar is used as binding material. This door type is commonly plastered.

Table 1, Door Types

SEMI-CIRCULAR ARCHED DOORS (DT1)		
	ELEVATION	PLAN
		DT1 
		SEMI-CIRCULAR ARCHED DOORS
		DT1a 
		RECESSED SEMI-CIRCULAR ARCHED DOORS
		DT1b 
		ORNAMENTED RECESSED SEMI-CIRCULAR ARCHED DOORS
SEGMENTAL ARCHED DOORS (DT2)		
		DT2 
		SEGMENTAL ARCHED DOORS

The type coded DT1a is a subtype of semi circular arched door. This door is also a semi-circular arched door, but the door opening is recessed from the wall surface about 15cm. This type is only seen at the entrance through Z01 and there is a circular terra cotta pipe on the top of the recessed door. The span of this door is 0.70m. Below the springing line, the construction material is stone and brick fragments. Mud

mortar is used as binding material. Above the springing line, the arch shape is given by bricks. Lime mortar is used as binding material. Due to the detachment the plaster at the exterior face of the door has not remained but the interior face is plastered.

The type coded DT1b is also a subtype of semi circular arched door. This door is also a semi-circular arched door, but the door opening is recessed from the wall surface about 10cm. This type is only seen at Z08 (D10). The span of this door is 0.61m. There is ornamentation on the top of door which is a reverse-ogee arch shape made by plaster.

The type coded DT2 is a segmental arched door. This door type is seen at Z05 (D5), Z07 (D8) and Z08 (D11). The span of this door type differs between 55cm to 75. Below the springing line, the construction material is stone and at some of the examples brick fragments are observed. Mud mortar is used as binding material. Above the springing line, the arch shape is given by bricks. Lime mortar is used as binding material. The surface of this door type is plastered.

2.6.2 WINDOWS

There is only one window existing in the building. This window is on the wall between the spaces Z07 and Z07. The window has a semi-circular arched shape. The height of the window is 0.83m and the span of the window is 0.65m.

2.6.3 NICHE

There is only one niche in the building. This niche is on the south wall of the space Z08. The height of this niche is 1.07m and the span is 0.66m.

2.6.4 SEKI

There are not any complete *sekis* of the hamam at present. Only the traces of *seki* are visible in spaces Z05, Z07, Z08 and Z11. In some of this spaces; forms, dimensions and construction techniques of the *sekis* can be predictable. A classification can be done according to the dimensions of the *sekis*.

There are three types of *seki* observed in the building. The first one coded as S1 is only seen at Z05. Only the dimensions of the *seki* are observed. There is no detail about the construction technique of the *seki* except the lime plaster finishing on it. The dimensions are 0.47m in height and 0.59m in width.

The *seki* in spaces Z07 and Z08 are similar. They are both close to ground in height and their construction technique is visible. This type is coded as S2. The dimensions of this type are approximately 0.14m in height and 0.65m in width. Rubble stones are used as the construction material and lime mortar. The surface is covered with lime plaster.

The last type is coded as S3 and seen only at Z11. Some part of the *seki* has still remained. The dimensions of the *seki* are 0.48m in height and 0.47m in width. The construction technique is rubble stone masonry. The surface is covered with horasan plaster.

2.6.5 KURNA

There are not any *kurnas* remained in the hamam at present. There are only the traces of them in some of the spaces. In Z04 and Z07; the location of *kurnas* are visible. In some of the spaces the places of them can be distinguished through the circular holes on the terra cotta pipes.

2.7 STRUCTURAL SYSTEM, CONSTRUCTION TECHNIQUE AND MATERIAL USE OF THE BUILDING

At hamams, because of the construction technology, the materials used at building are highly related to the structural system and construction technique of the hamam. Therefore; these aspect are going to be described together.

The main structural system of the hamam is load bearing walls and arch systems with domed and vaulted superstructure. The load bearing systems of the walls are stone masonry with a thickness ranging from 60cm to 90cm and the thickness increases while going from the entrance to the water depot. The super structure of the building

is vaults and domes. The spaces Z01, Z02, Z03 and Z10 are covered by barrel vaults. The other spaces are covered with domes that are connected to the walls with transition elements. The floors of some spaces are carried on stone piers which form the canals of *cehennemlik* which can be observed from Z06, Z07 and Z08.



Figure 25, Load Bearing Wall Thickness Distribution

2.7.1 WALLS

Rubble stone is used with brick fragments at both interior and exterior walls of the building. A categorization for the walls of the hamam can be made according to the binding material. The binding material is mud mortar at interior walls and lime mortar at exterior walls. The finishing at the walls changes from spaces to spaces and also at exterior in comparison to interior.

At the exterior walls of the hamam, rubble stone and brick fragments are used with lime mortar for the construction of the walls. The thickness of the exterior walls varies from 70 to 80 cm.

Inside the building, all the walls are constructed with this technique. The finishing material changes from space to space. Due to the spaces having different functions; the finishing material varies from one space to another related to the function of the spaces. Different finishing materials are going to be described at below.

Type A - The walls of Z01, Z02, Z09 and Z03 are constructed with rubble stone masonry with brick fragments as wall construction technique and the finishing layer of the walls of these spaces is lime plaster. However, at the walls of Z03, the finishing layer is mostly demolished. But from the remains; it is seen that lime plaster was used as finishing material on the masonry wall.

Type B - The walls of Z04, Z05 and Z06 are constructed with rubble stone masonry with brick fragments as wall construction technique. The binding material is mud mortar at these walls. There are two different plasters observed at the walls of these spaces. Horasan plaster is underneath lime plaster at an approximate level of 0.20m below the datum line.

Type C - The walls of Z07 and Z08 are constructed with rubble stone masonry with brick fragments as wall construction technique. The binding material is mud mortar at these walls. There are two different plasters observed at the walls of Z07 and Z08. Horasan plaster is underneath lime plaster till the cornice below the dome.

Type D - The space Z10 which is the water tank of the hamam has a thick layer of plaster on its walls. It is seen that there are two layers of horasan plaster that were applied underneath the lime plaster layer. Due to the deteriorations the level of them cannot be determined.

2.7.2 TRANSITION ELEMENTS

For the domed spaces of the hamam; three types of transition elements are used. They can be categorized as;

- Turkish Triangles (seen in the spaces Z06, Z07, Z08)
- Pendentives (seen in the spaces Z01, Z09, Z04 with stalactites)
- Tromp (seen in the space Z05)

Turkish triangles are used in the spaces Z06, Z07, and Z08 in three different compositions. The main construction material of the Turkish triangles is brick with lime mortar. On the face of the Turkish triangles bricks are used to give the shape and supported with rubble stones. The width of the Turkish triangles band is 115cm. Pendentives are used as transition elements at spaces Z01 and Z09. At Z04, pendentives are in the form of stalactite. The stalactites are formed by bricks with lime mortar. Tromp is used as transition element at Z05. The construction materials of tromp are brick and lime mortar. All of these transition elements are covered with lime plaster.

2.7.3 SUPER STRUCTURE

The most deteriorated and collapsed part of the building is the superstructure. At spaces Z01, Z06 and Z09, the domes are demolished. And there is a deep crack going lengthwise at the vault of space Z10.

2.7.3.1 VAULTS

At the rectangular spaces of the building, barrel vaults are used lengthwise as superstructure. Two types of barrel vaults are used at the building. At space Z02 shouldered profiled barrel vault is used. At spaces Z03 and Z10 which is also water tank of the hamam has a semi circular profiled barrel vault.



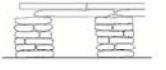

The material and construction technique at Z02 and Z03 is different from Z10. At Z02 and Z03 brick and lime mortar are used to build the super structure, whereas at

Z10 rubble stones and lime plaster are used for the construction. They are both covered with lime plaster.





2.7.3.2 DOMES

The construction technique of the domes remained are similar throughout the building. They are all constructed with bricks having similar shapes and dimensions and the binding material is and lime mortar. Interior faces of the domes are all lime plastered. The illumination holes do not have an order corresponding between spaces. Their shapes are given with terracotta pipes. The thickness of them is about one cm. In addition to that, at the exterior faces of the domes; stones are projected from the surface of the dome.



FLOOR

Definition:	The floor covering is marble, underneath the marble floor covering slates are used for leveling. This type of floor is observed at the spaces coded as Z01, Z02, Z03.		
Definition:	The floor covering is marble, the covering is supported by slates underneath. This system stands on the pillars of cehennemlik. This type of floor is observed at the spaces coded as Z04, Z05, Z06, Z07, Z08, Z09, Z10 and Z11.		



DOMES

Definition:	The construction material is Brick, the thickness of the brick is constant at all heights. Lime Plaster is seen at the outer surface of the dome. This type of arch is seen at Z07.		
Definition:	The construction material is Brick, the thickness of the brick is constant at all heights. Lime Plaster is seen at the outer surface of the dome. There are stone linearly attached to the dome. This type of arch is seen at Z04, Z05, Z08.		

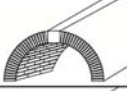





WALLS

Definition:	The wall construction system is rubble stone masonry, there are brick fragments between rubble stones irregularly. All the walls at the Hamam was constructed with this technique.		
-------------	--	---	---









ARCH

Definition:	The arch is constructed by edge bedded bricks and lime mortar as binding bricks. This type of arch is seen at Z01.		
-------------	--	---	---

VAULTS

Definition:	Barrel vault with shouldered profile constructed with brick. This type of arch is seen at Z02.		
Definition:	Barrel vault constructed with brick. This type of arch is seen at Z03.		
Definition:	Barrel vault constructed with rubble stone. This type of arch is seen at Z11.		

TRANSITION ELEMENTS

Definition:	TURKISH TRIANGLES On the face of the Turkish Triangles bricks are used to give the shape and supported with rubble stones. This type of arch is seen at Z06, Z07, Z08.		
Definition:	PENDENTIVE Brick and Stone are used together in Pendentive. As binding material lime mortar is used. At the edge of the pendentive a line of brick with 4cm thickness. This type of arch is seen at Z01, Z09.		
Definition:	STALACTITE The main construction material is Brick. Lime Plaster is used for giving the curved faces. This type of arch is seen at Z04.		
Definition:	SQUINCH The main construction material is brick. Lime mortar is used as combining material. This type of arch is seen at Z05.		

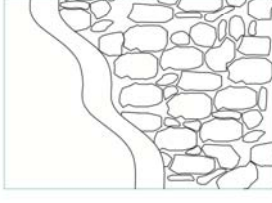
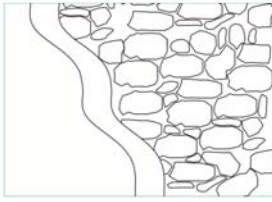
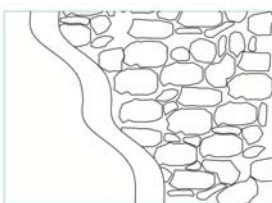
Finishes	Horosan Plaster	Lime Plaster	Lime Wash
		●	●
	●	●	●
	●		

Figure 26, Construction Technique and Material Use Legend.

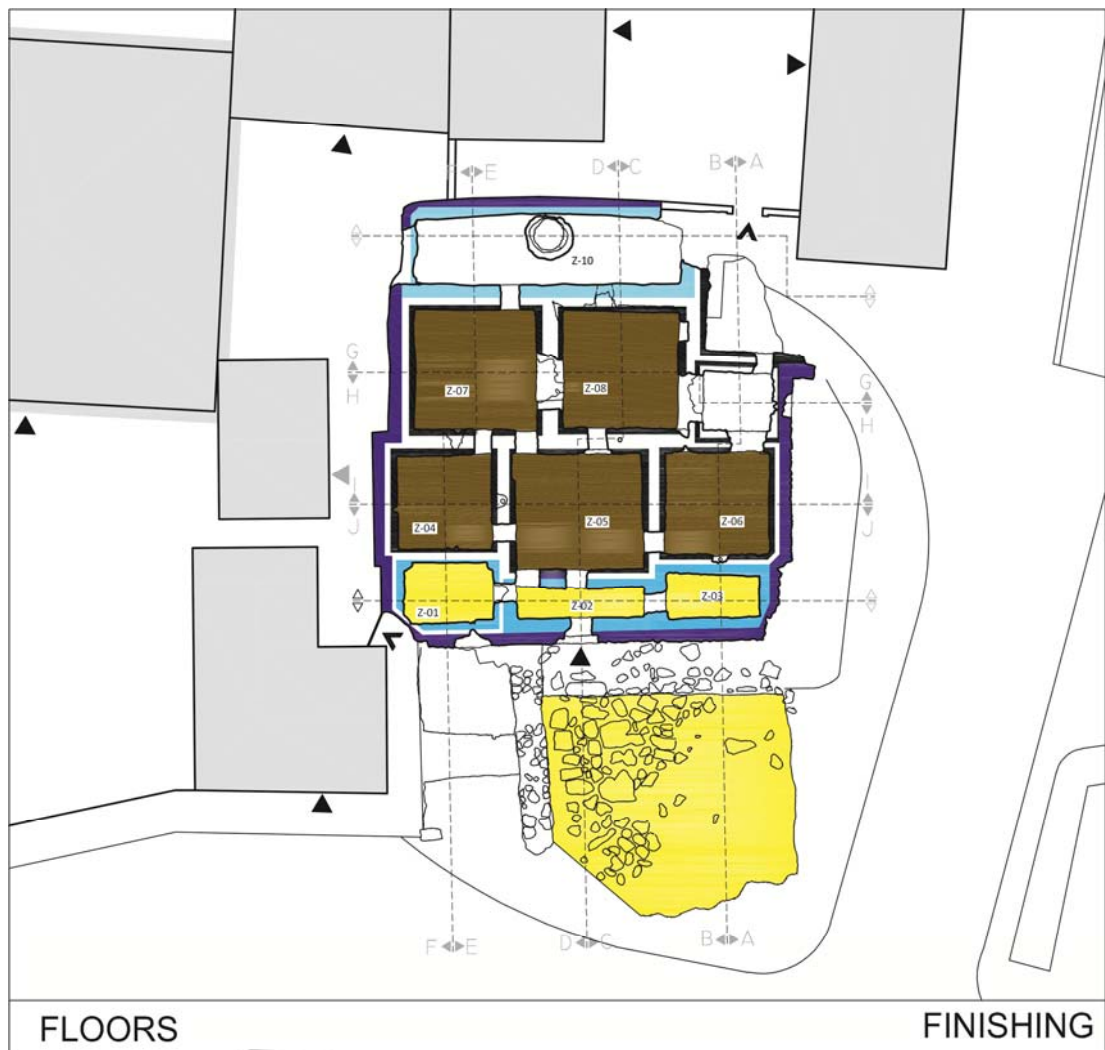


Figure 27, Construction Technique and Material; Floor Covering and Finishing



Figure 28, Construction Technique and Material; Domes

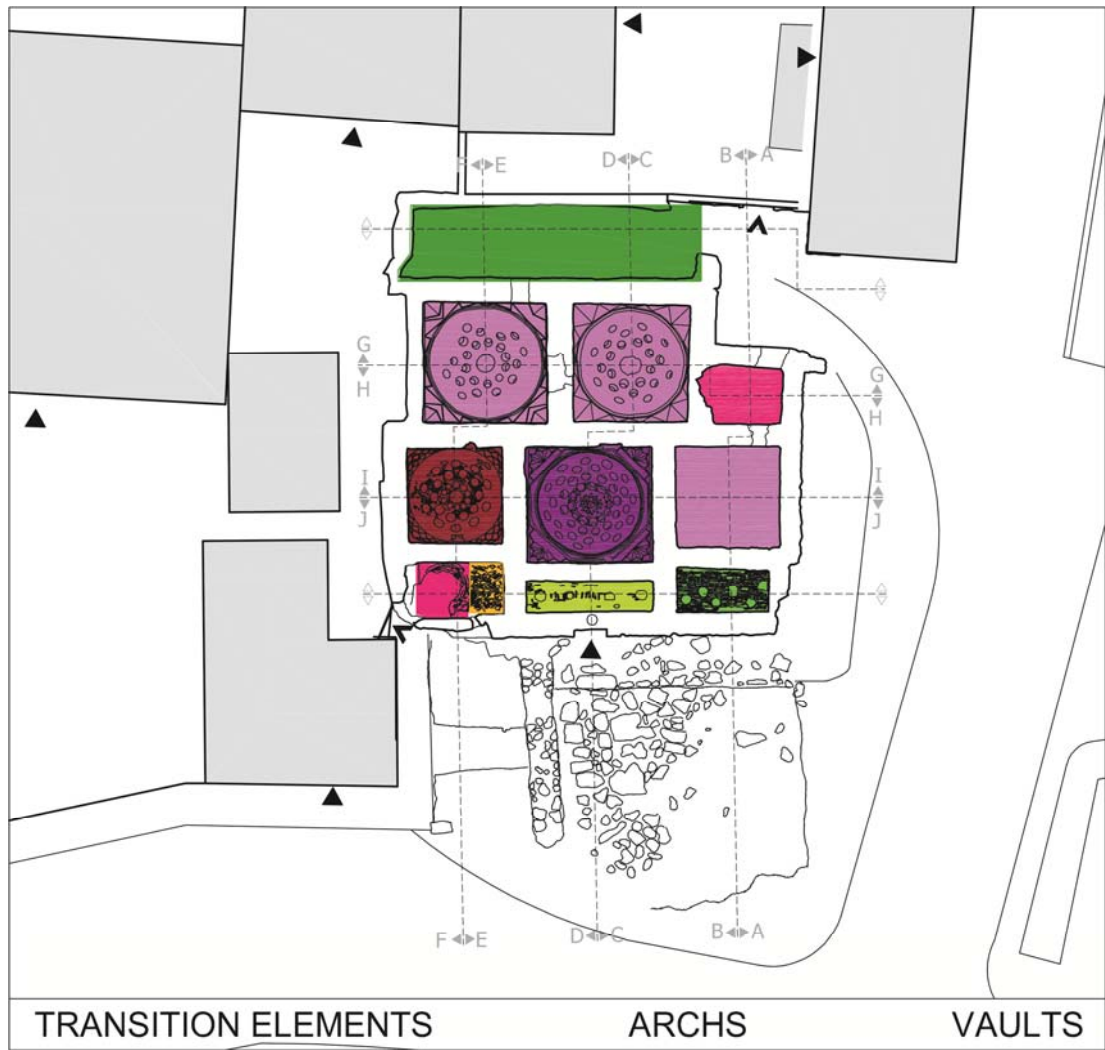


Figure 29, Construction Technique and Material; Superstructure

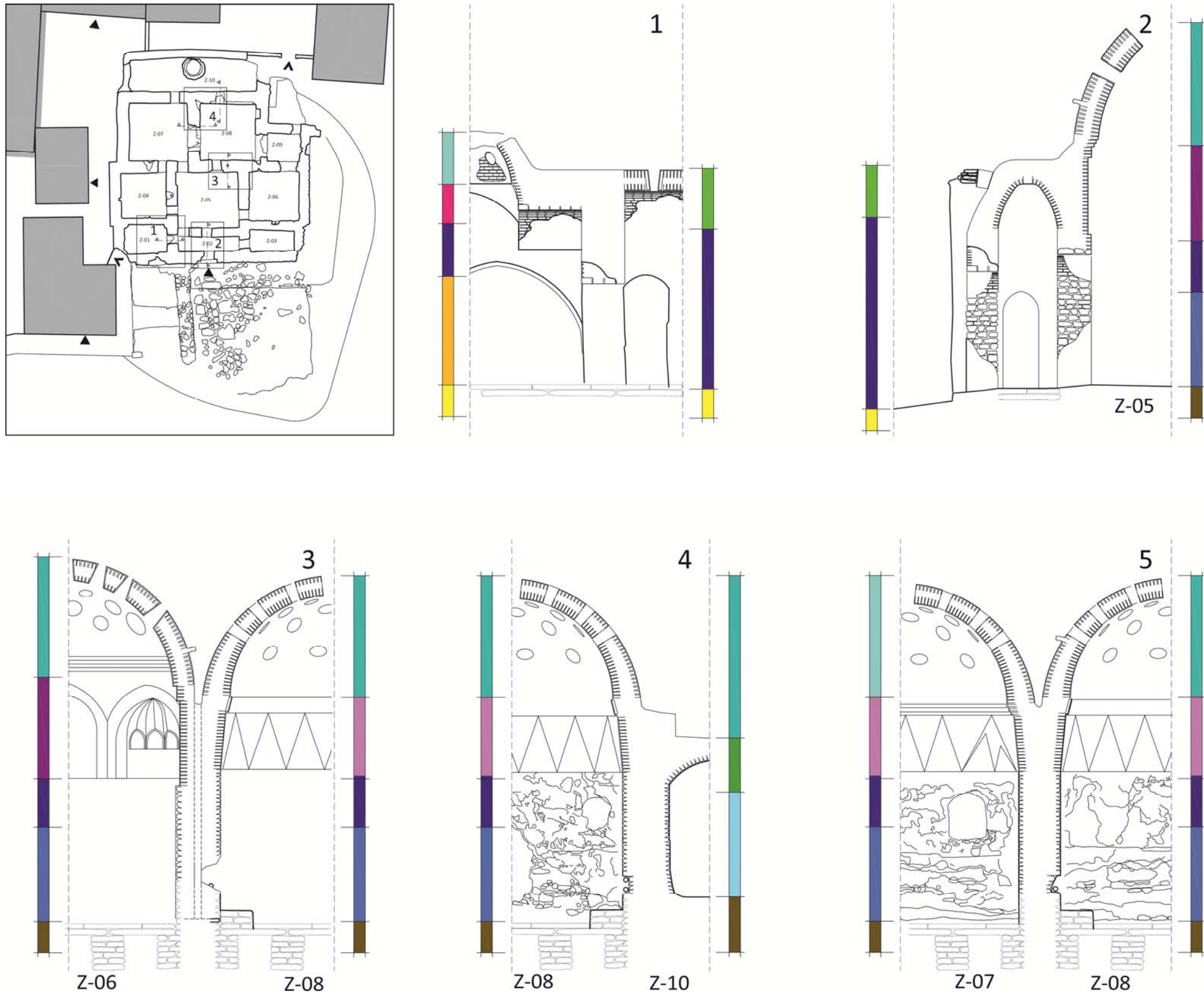


Figure 30 Construction Technique and Material; Distribution of the System

2.8 HEATING SYSTEM

2.8.1 KÜLHAN

Külhan of the hamam is not visible because of the adjacent building at the east. However; approximate area of *külhan* can be traces from the *cehennemlik* system of the *hamam*.

2.8.2 CEHENNEMLİK

Cehennemlik of the hamam can be observed at spaces Z04, Z05, Z06, Z07 and Z08 through the collapsed floor coverings. *Cehennemlik* has a pired structure underneath the floor covering forming canals. *Cehennemlik* is used to transmit the heat through the spaces. The heat first comes to Z07 then travels around the other spaces. These piers are constructed with rubble stone masonry. Lime mortar is used as binding material. On top of the stone piers of *cehennemlik*, slate is used as finishing at the floor marble is used as the last layer of this system. The dimensions of these piers are measured at Z07, Z08 and Z06. In Z07 and Z08 the dimensions of the canals maintained by the piers are approximately 0.70m in width and 0.45m in height. In addition to that; in Z06 the dimensions of the canals are decreased to 0.52m in width and 0.45m in height.

2.8.3 TÜTEKLİK

*Tüteklik*s are made of terracotta pipes and have a cylinder shape. They are located in the wall structure vertically connecting *cehennemlik* section the exterior. In Çukur Hamam, *tüteklik*s are observed in spaces Z04, Z06, Z07 and Z08. The diameters of the terracotta pipes of *tüteklik*s are approximately 0.12m. Because of the earth and bushes, *tüteklik*s are not visible at the roof. The terracotta pipes are inserted inside the rectangular shaped walls which is situated vertically along the wall.

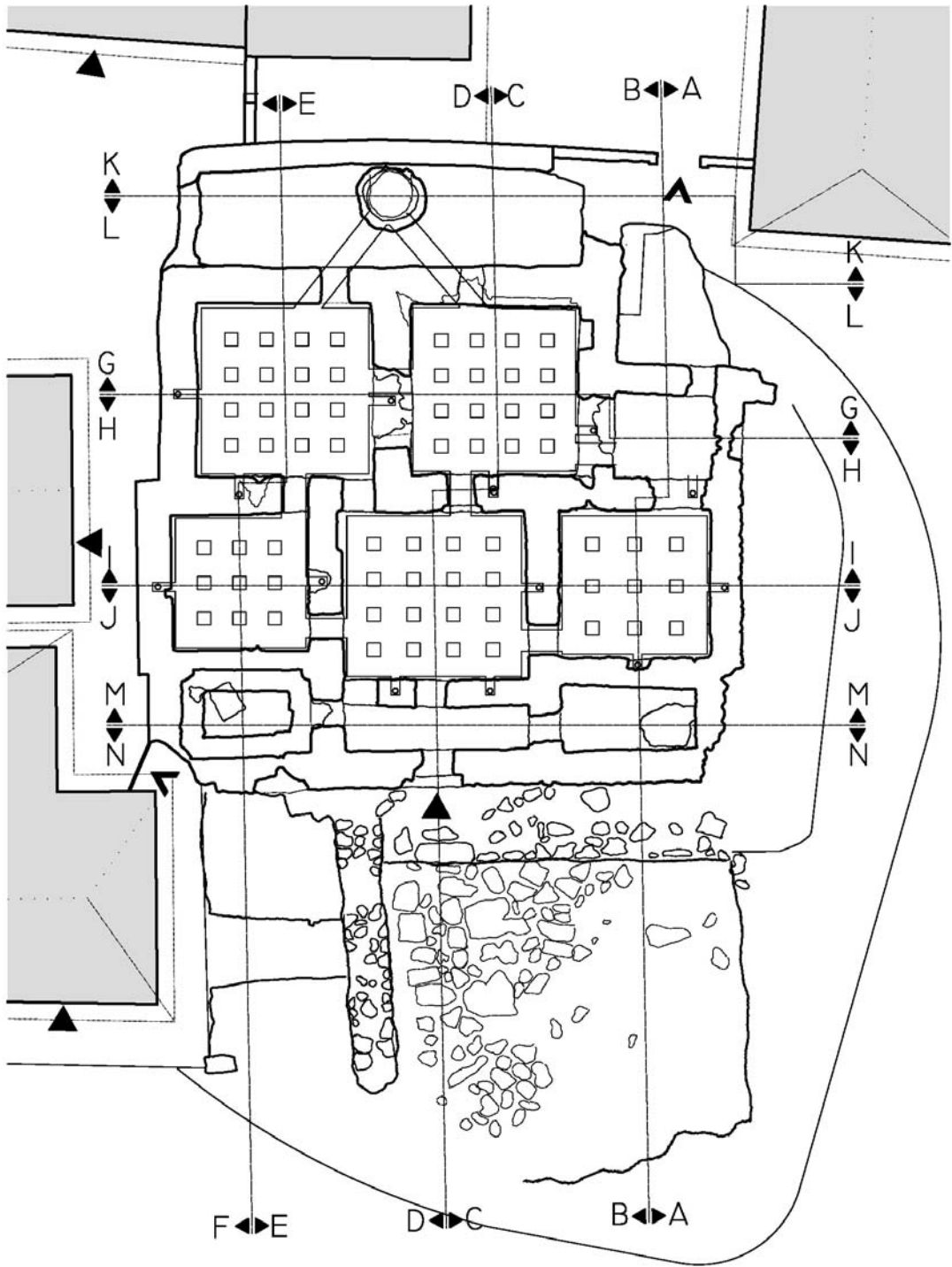


Figure 31, Heating System

2.9 WATER DISTRIBUTION AND DISPOSAL SYSTEMS

2.9.1 CLEAN WATER DISTRIBUTION SYSTEM

Water tank, terracotta pipes and *kurnas* basins are the elements of the water distribution system in *hamams*. Hot and cold water are distributed from the water tank to the spaces through terracotta pipes. Then by the taps, water is transferred to the *kurnas*.

In Çukur Hamam, water comes to the water tank by terracotta pipes from the west wall of Z11. The pipes are not visible at the north wall of Z11 but the level of the terracotta pipes are the same as it is at the west wall of Z10; the water tank. Cold and hot water are distributed to the bathing spaces by two rows of terracotta pipes. The *kurnas* of the hamam has not remained. Therefore there are not any information on the taps and basins of the bathing spaces. The dimensions of the pipes which are carrying hot and cold water are 0.09m in diameter and 0.35m in width

2.9.2 WASTE WATER DISPOSAL SYSTEM

In Çukur Hamam, the floor is mostly covered with earth and in some of the spaces with debris. So the waste water disposal system can be traced only in some spaces. In Z07; at the south part of the floor, it's easily seen that a canal is carved on the marble floor covering. The continuity of this canal is not traceable because of the absence of the adjacent marbles and slates underneath.

There is a hole through the space at the south wall of the space Z03 to outside. In addition to that; the discharge hole is observed from outside on west facade where the remains of *soğukluk* section is.

As İpekoglu, et al. (2004) explains; the open wastewater channels are generally located along the walls and/or along the bottom edges of the elevated platforms, which are generally covered with marble. The waste water is directed towards these channels with the help of the inclined floor arrangements of the bathing spaces and

discharged either from the toilet or from the corner of the one wall of the structure to the outside⁴³.

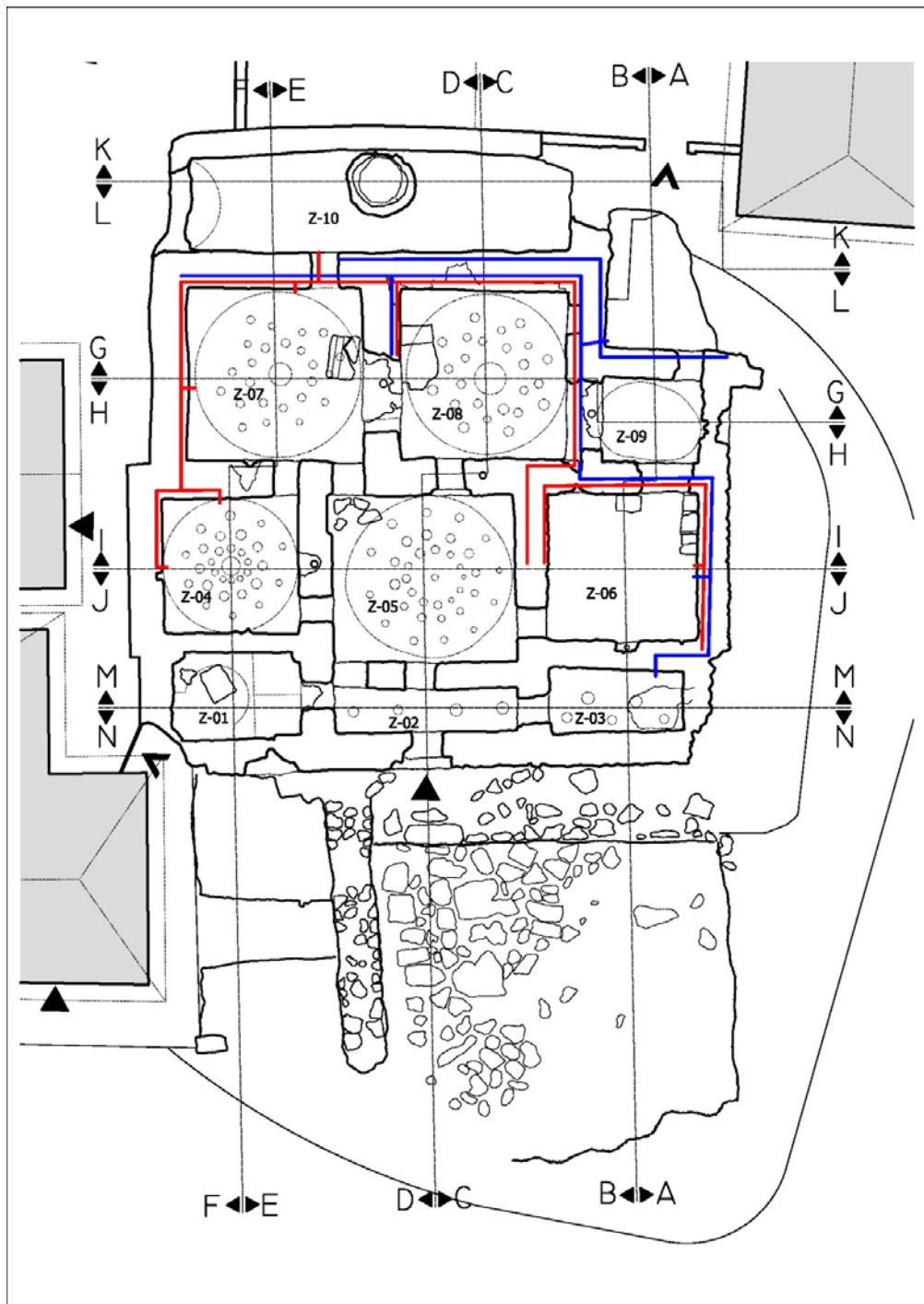


Figure 32, Clean Water Distribution System

⁴³ B. İpekoğlu et al. 2004, pp. 5-6

2.10 MATERIAL DECAYS AND STRUCTURAL PROBLEMS

The analyses of material decays and structural problems of hamam are based on visual observations held in the site survey. First of all, the material and structural condition of the building is assessed. Afterwards, basic material deterioration types that are common the building are described.

















DEMOLISHMENT	
MATERIAL LOSS	
AREA LOSS	
UNIT LOSS (STONE, BRICK)	
LOSS OF MORTAR	
CRACK / FISSURE	
CRACK	
FISSURE	
DETACHMENT OF MATERIAL	
DETACHMENT OF PLASTER	
BLIND DETACHMENT	
DISCOLORATION / DEPOSITS	
CHANGE IN COLOR	
RUST	
EARTH DEPOSIT	
BIOLOGICAL GROWTH	
GRASS MACROFLORA	
TREE	
MOSS MICROFLORA	
RISING DAMP	
RAIN WATER PENETRATION	

Figure 33, Deterioration Legend

2.10.1 MATERIAL CONDITION OF THE BUILDING

The building was abandoned a long time ago. Therefore; domes of the spaces Z01, Z06, Z09 were demolished in time and depending on that; rain water penetration caused micro flora and detachment of plaster at upper parts of the walls. Rising damp is also one of the important problems at the building. Vandalism is another problem for the building. On the bases of these, the material condition of the building can be defined as severe.

2.10.2 DECAY FORMS

2.10.2.1 RISING DAMP

The name of the hamam is Çukur hamam. It's because the building is at a lower ground than the other buildings. The building is also close to the river and the moisture level of the ground is very high due to these aspects.

The foundation of the building is defenseless to moisture and a drainage system was not installed to the building before. The moisture at the level of foundation rises by the pours at the mortar from foundation to the upper levels of the walls. This activity causes loss of mortar and detachment of the plaster through the level where the moisture reaches.

2.10.2.2 RAIN WATER PENETRATION

The illumination holes at the building do not have any glass covering on them and Z01, Z06, Z09 do not have a superstructure. Due to this situation, rain water that has been penetrating through these uncovered areas causes change in color, micro flora and in some occasions loss of plaster.

2.10.2.3 DEMOLISHMENT

The collapsing of a space, a part of a space or the superstructure is stated as the demolition at the building. The *soğukluk* section of the hamam, the domes of the spaces Z01, Z06 and Z09 are demolished parts of the building.

2.10.2.4 MATERIAL LOSS

Material loss as a decay form is considered in three subheadings considering the building materials that are lost that can be categorized as part of the building, unit materials, and binding materials.

AREA LOSS - At the building, the partial losses of the structural elements such as walls, transition elements and domes are described as area loss in the legends.

UNIT LOSS - It is the unit loss of any structural element at the building. The loss of stone plates at the floor covering is described as unit loss.

LOSS OF MORTAR - There are two important causes for loss of mortar at the building. Rising damp and vandalism are the causes for this decay form. The load bearing capacity of the walls are decreased because of this at spaces Z02, Z03.

2.10.2.5 CRACKS AND FISSURES

Diagonal cracks which can be seen at the walls of the spaces Z01, Z03, Z07 and at the south wall of Z10 are important structural defeats as cracks at the building. Fissures can be seen at the plaster of the walls at most of the spaces.

2.10.2.6 DETACHMENT OF MATERIAL

Detachment Of Plaster - Detachment of plaster is the most common decay form observed at the building. The reasons why detachments of the plaster occur at the building are rising damp, rain water penetration and vandalism.

Blind Detachment - At the building, at spaces Z04, Z08, at some areas on the walls, the plaster holds on to the wall only at the edges. The centre of the plaster has detached from the wall surface. This deterioration type is defined as blind detachment.

2.10.2.7 DISCOLORATION AND DEPOSITS

Change in Color - The water leak dripping from the lightening holes (oculi) resulted with efflorescence which shows itself as color changes on the surfaces.

Rust - On the west wall of space Z05, the iron door case is rusted. The rust penetrates to the wall at the junctions.

Deposits - The inner spaces are filled with the earth deposit. Because of that the original floor is invisible.

2.10.2.8 BIOLOGICAL GROWTH

There is grass on roof and the on the spaces where the covering domes are demolished. There is also a tree on the north wall of space Z11.

On the surfaces of inner spaces moss formation is observed. The moss formation increases in the wall junction corners.

2.10.3 STRUCTURAL STATE OF THE BUILDING

Rising damp, vandalism and trees growing from the wall structure have weakened the load bearing walls in some spaces. The walls separating spaces Z07 and Z07, Z08 and Z09, Z04 and Z07, the east wall of the spaces Z07 and Z08 were damaged.

Rising damp caused loss of plaster and mortar on the south façade, and the walls of Z01, Z02 and Z03 which decreased the load bearing capacity of these walls.

On behalf of these, the superstructures of spaces Z01, Z06, Z09 are demolished and because of the deep cracks on the vaults of spaces Z03 and Z10 are severely deteriorated.



Figure 34, Deterioration Mappings, Plan

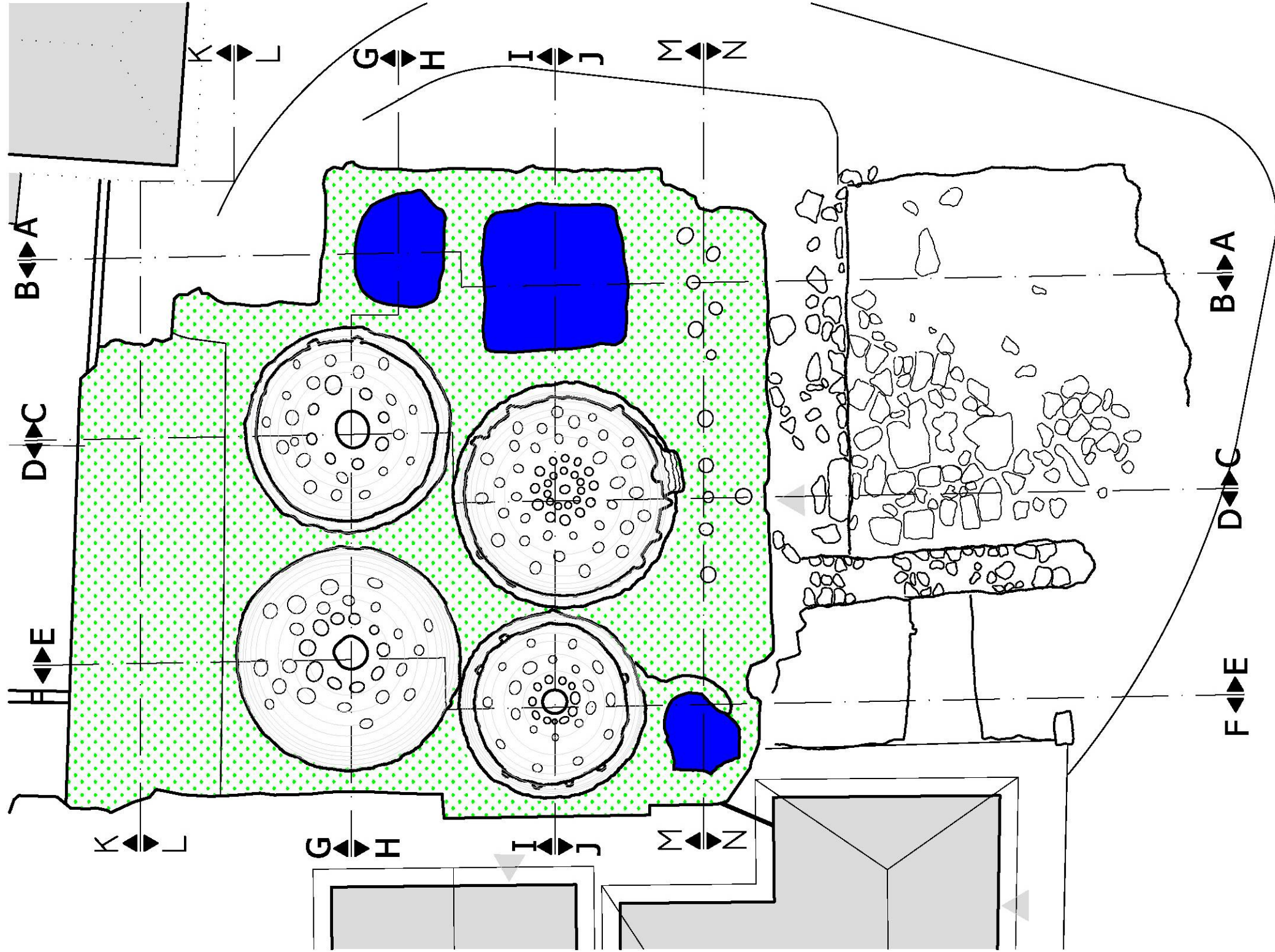


Figure 35, Deterioration Mappings, Roof Plan

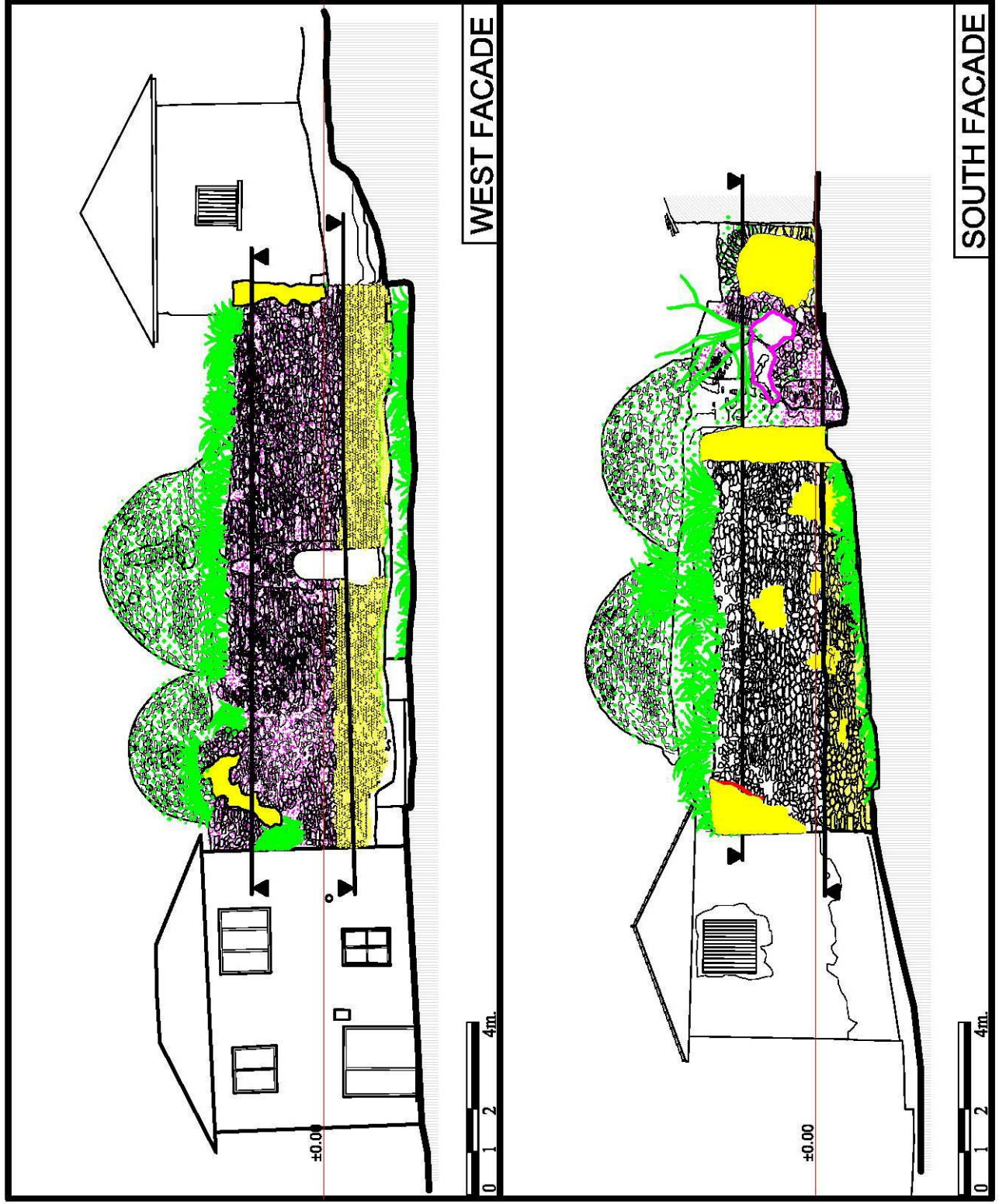


Figure 36, Deterioration Mappings, Facades

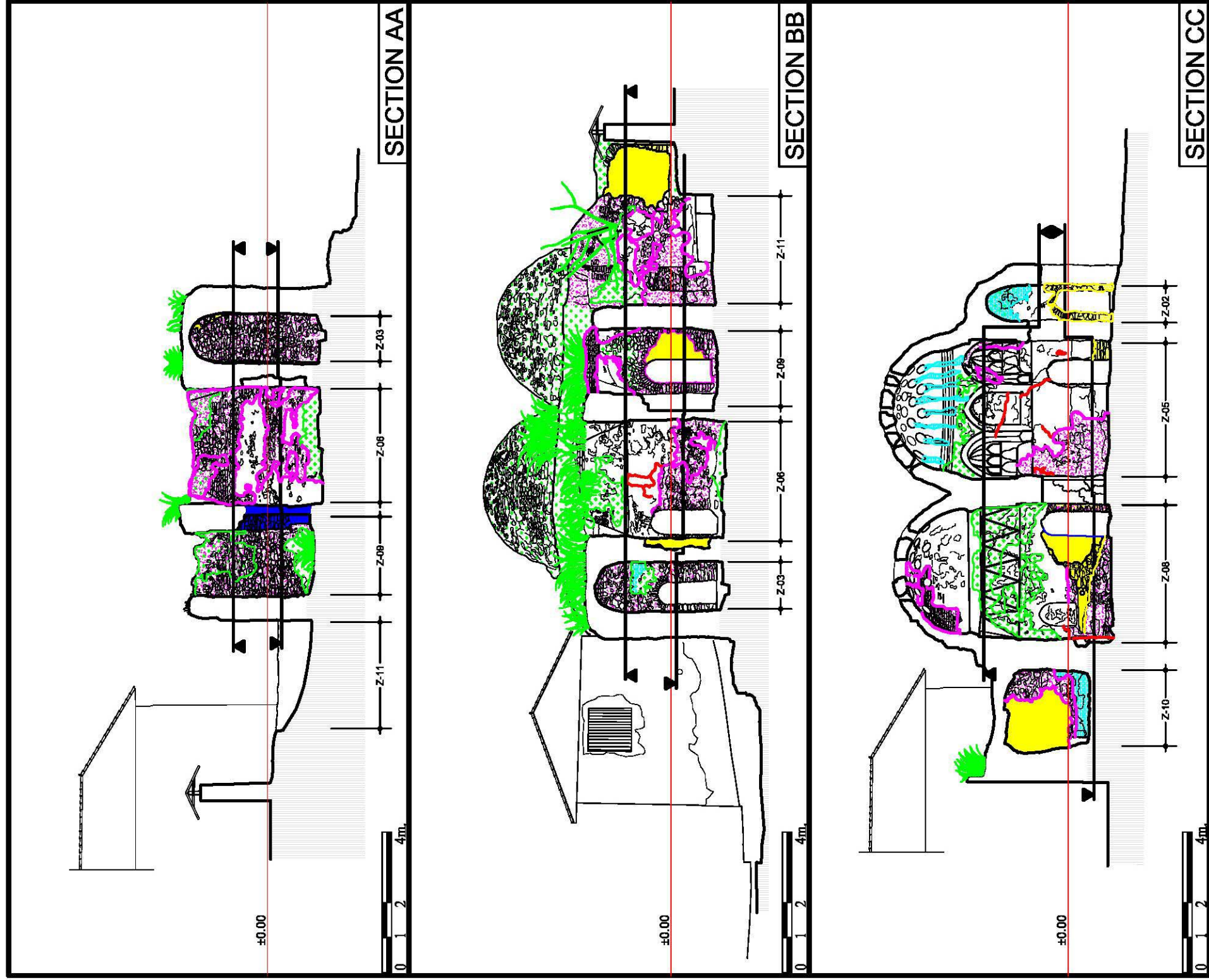


Figure 37, Deterioration Mappings, Section AA, BB, CC

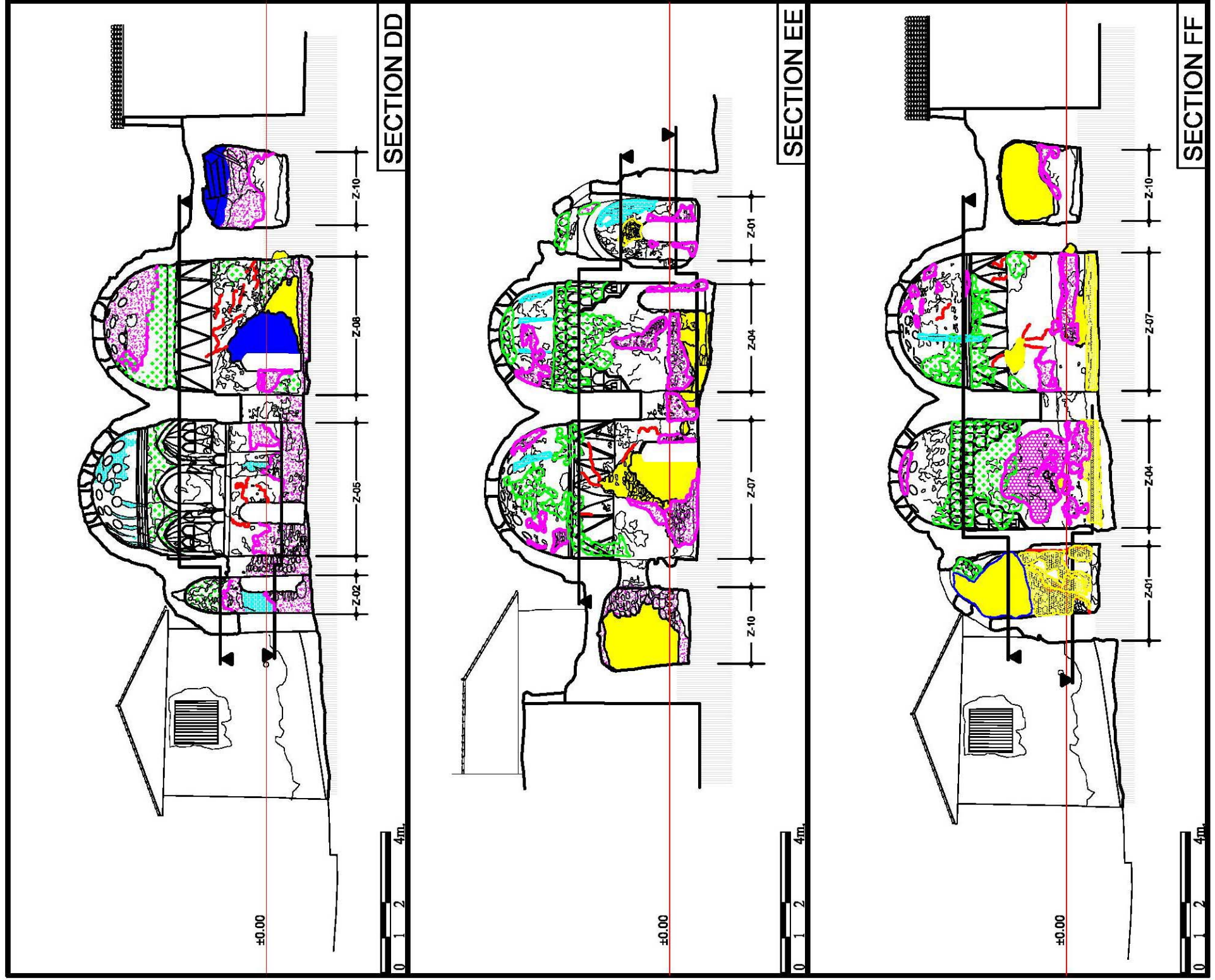


Figure 38, Deterioration Mappings, Section DD, EE, FF

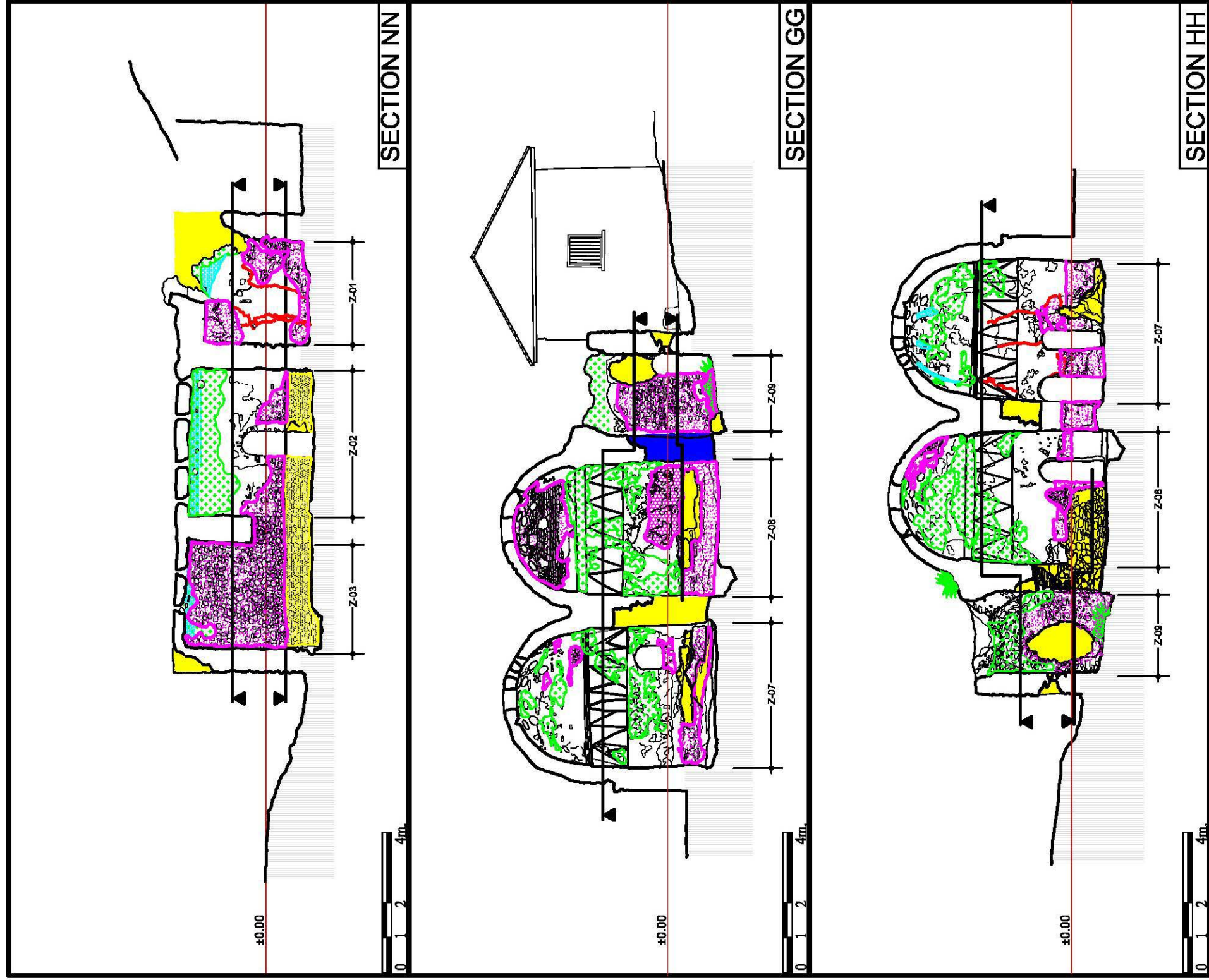


Figure 39, Deterioration Mappings, Section NN, GG, HH

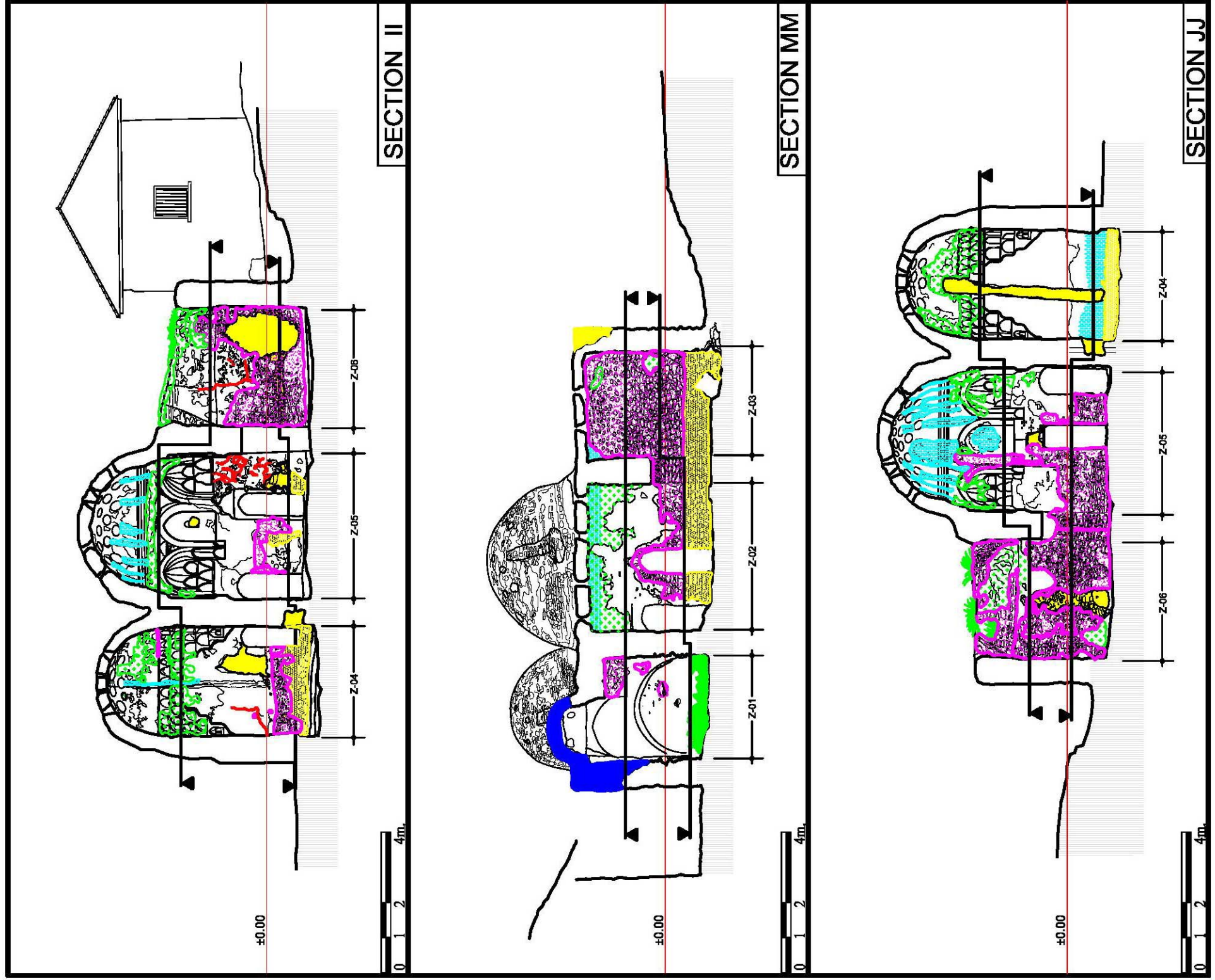


Figure 40, Deterioration Mappings, Section II, MM, JJ

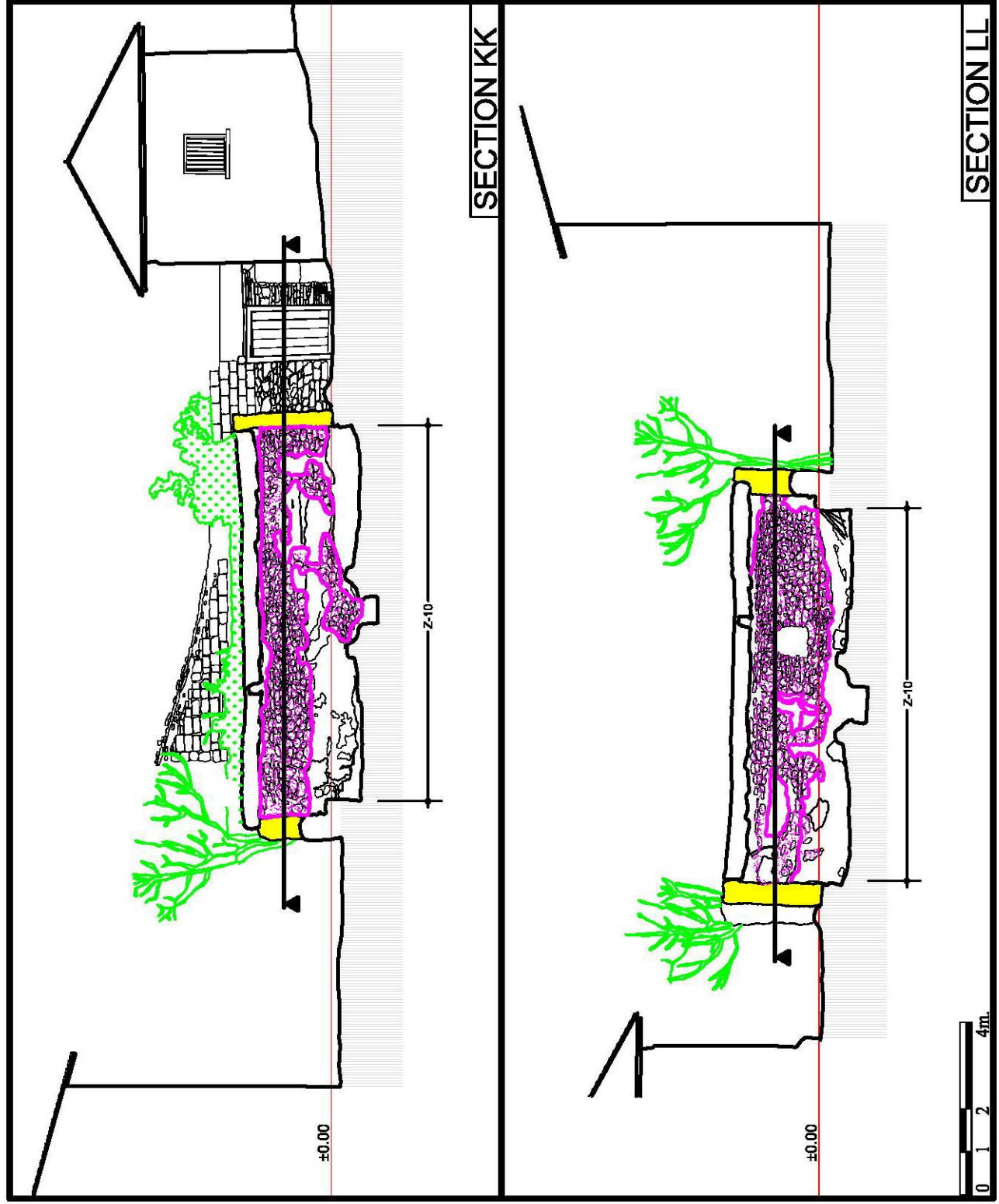


Figure 41, Deterioration Mappings, Section KK, LL

CHAPTER 3

HISTORICAL RESEARCH

3.1 HISTORY OF BİRGİ

Birgi has always been one of the important cities of Anatolia. Although the information for the prehistory of Birgi is not sufficient, the history of the city can be dated to prehistory. However, it is known that settlements have been established in the surroundings of Birgi since 3000 BC. The region had been called with the name "Assuva" in Hittite period, and been in the borders of Hittite Empire beginning with 1120 BC, which is the period of King Tuthalya IV. In the late sixteenth century BC, due to its strategic situation at the connection point of the two roads running from Sardis to Anatolia and to Tire, it was an important settlement. Apart from these, it is known that it might be a summer city of King Croesus of Lycia.⁴⁴

Until the Byzantine period, the sources do not mention a settlement on the location of today's Birgi. In the Byzantine period, Birgi was called with the name Pyrgion (Dios Hieron)⁴⁵. Like many other cities of the period in the region such as; Hypaipa most probably situated at the north of Ödemiş, Thyaira at the North-East of Bayındır and Ideiphyta at the east of Tire, it was set up in-between small hills on the side of the plain and at a position suitable for a castle structure.⁴⁶

The citadel of Byzantine Birgi was captured by Sasa Bey, who was the groom of Emir Menteşe, and since then (1304); Turks have settled in the town. In April 1348

⁴⁴ Nezir Başgelen, 1987, p.2

⁴⁵ N. Başgelen, 2008, p.5

⁴⁶ Darkot, 1961, p.632

Gazi I. Umur Bey was killed when they tried to take İzmir Coast Castle. He was buried in his father's tomb in Birgi.

After Gazi I. Umur Bey's death, his brother Hızır Bey (Ulubey) became the head of Aydınoğulları Türkmen Principality. Hızır Bey was the ruler of Ayasulug (Selçuk). He signed a severe agreement with Frenks in 1348. In parallel with this event, the Aydınoğulları Türkmen Principality started to collapse. In 1348 the center of Aydınoğulları Türkmen Principality was changed from Birgi to Ayasulug.

In the 14th century, Birgi was a metropolitan center of Byzantines. However, in 1387 it was reduced to episcopacy. After that; Birgi episcopacy and Efes episcopacy were combined. In 1389; at I. Kosova War, Aydınoğulları Principality's soldiers and Ottoman soldiers battled together. In 1390 Ottoman Sultan Yıldırım I. Bayezid threatened Aydınoğulları Principality. Starting from Ayasulug (Selçuk) he came to Birgi. He put Ottoman soldiers to Birgi and surrounded castles. With his army he came to Allahdiyen'e (Alaktiyen) and then to Sardis. In 1391 Fahrettin İsa Bey was also buried dead. He was buried in Birgi near his father's tomb. After that Yıldırım Bayezid I gave the control of the Aydınoğulları Principality to his son Süleyman Çelebi.

After the defeat of Yıldırım I. Bayezit in Ankara War in 1402 by Timur Han; Timur gave the Aydınogulları territory to İsa Bey's sons Musa ve Umur Bey II. Therefore, Birgi returned back to Aydınogulları Principality's government. After the death of Umur Bey II in 1405, Cüneyd Bey became the ruler of Birgi and Aydınogulları Principality.

Ottoman Sultan Murat II gave the leadership of Aydınogulları Principality to Cüneyd Bey in 1422. Because of Cüneyd Bey's activities, Murat II marched to Aydınogulları Principality in 1424. He conquered the whole principality including Birgi, and awarded its leadership to one of his commanders Halil Yahşi Bey. Hence, Birgi became a part of the Aydın district centered at Tire. After the death of Cüneyd Bey in 1426, Aydınoğulları Principality became a part of the Ottoman territory. In 1443, income of Birgi started to be included among the annual funds of the Ottoman Sultan

Murat II. In 1451, Birgi was a part of the Aydın district centered at Tire, which was in turn a part of the Anatolian Governorship centered at Kütahya. In the document “Timar Defteri” from 1451, Birgi is stated to consist of 9 neighborhoods and 287 houses. The names of these neighborhoods are recorded as Dernekpazarı, Kadı, Ahi Germiyan, Sinli, Hisariçi, Sasalu, Taşpazar, Samut and Demürboğa. There were only six non-Muslim families in Birgi. In the 15th century, cultural activities were quite intense, the population was high and the economical state was very advanced in Birgi.

According to the records in “Defter-i Hakani” (register no. 166) from the year 1530 during the reign of the Ottoman Sultan Süleyman the Magnificent (1520-1566), Birgi included 106 villages, 12 communities, 13 farms, 6 mosques, 1 medrese (in city center), 9 masjids, 17 zaviyes, 2 lodgings for teachers, 8 baths, 345 stores, 4687 Muslim and 32 non-Muslim houses.

The city of Birgi was at its most advanced period in 1574, during which there were 118 houses only within the castle. This shows that the population inside the castle was around 600-650. Birgi, which was once the capital of Aydınoğulları Principality, became the second largest city after Tire, the capital of Aydın district, in the 16th century.

After the rebellions were suppressed in 1625, the outer castle of Birgi was demolished by the order of Sadrazam Murat Paşa, because it was being used by the rebels. According to Ottoman documents “Temettüat Defterleri” from 1844, Birgi consisted of the neighborhoods Sarubey, Çörekbaşa, Manastır, Kurtgazi, Akmesicid, Taşpazar, Hızırlık, Karataş, Börekçi, Kızılmescid, Camiikebir, Sasalu, Sine, Dernek and Timurbaba, and included 772 houses. This indicates an approximate population of 3900.

After the reorganization of Aydın district in 1867, Birgi became a township and joined the jurisdiction of Ödemiş. According to the document “Aydın Eyaleti Salnamesi” of 1303, municipal government was established in Birgi in 1887.

The travelers who visited the town at various times provide written documents about its historical development. First of all, Ibn-i Batuta's description comprising Aydınoğlu Mehmet Bey's period should be mentioned.⁴⁷ Evliya Çelebi who visited the city in the second half of the 16th century describes a castle at the end of a rocky brook and mentions Celali Cennetoğlu - the rebellious who lived in this castle in the early seventeenth century. He also mentions 400 residential buildings within the citadel walls and 2400 more at lower districts, seven schools, one bedesten of 200 stores and two hans, and four timber bridges over the brook. Houses were surrounded by vineyards and gardens; fruit growing and thread making were common economical activities.⁴⁸ Texier, who visited the city in early nineteenth century; describes an elegant bridge over the brook, trees shadowing the roads and colourful houses, and mentions construction material probably transported from Hypaipa.⁴⁹ He stresses the absence of any monument from the prehistoric ages, but mentions some archaeological ruins.⁵⁰

Between 1920 and 1922, the town was occupied by Greeks. During the fire at this period, many historic buildings were badly damaged, while some were totally collapsed. İmam-ı Birgivi Medresesi was also damaged during the fire, but the Great Mosque and the tomb were out of the disaster. The decline that had started with the development of new cities on the plain was accelerated with this last event.⁵¹

In 1923, Birgi was annexed to Ödemiş which is a town in the province of İzmir, in the Turkish Republic. In 1939, the Birgi River flooded and caused substantial damage. Leaving the historical market of Birgi that lies to the south of the Derviş Ağa Mosque that was demolished in the flood, the stores in the market were carried to a higher ground in the east and olive trees were planted in the place of the historical market that was ruined by the flood.

⁴⁷ Parmaksızoğlu, 1971

⁴⁸ Evliya Çelebi, 1935, p.174-176

⁴⁹ Texier, 1982 pp. 248-250

⁵⁰ Ibid., p. 248-250

⁵¹ Darkot, 1961, p. 633

The large bridge in the city was completed in 1940. The cadastral map and the development plan were completed in 1947.

3.2 PRESERVATION ACTIVITIES IN BİRGİ

1940 - Destruction of Çakır Ağa Konağı was stopped by Ödemiş Mayor Mustafa Bengisu, Ödemiş District Governor, and İzmir Governor Kazım Dirik Paşa.

1946 - Dervisağa Mosque, İmam-ı Birgivi Madrasa, Aydınoğlu Mehmet Bey Mosque were restored.

1947 - "Birgi Fenni Haritası" was prepared.

"Birgi Master Plan" was prepared by Kemal Ahmet Aru, Orhan Safa and Celile Berk.

1973 - Restoration of Çakır Ağa Konağı was concluded. (GEEAYK)

1774 - 1977 -135 Houses and 26 monumental buildings were registered. (GEEAYK)

1975 - 1978 - İmam-ı Birgivi Madrasa and Aydınoğlu Mehmet Bey Mosque were restored.

1988 - Most part of Camikebir and Kurtgazi districts were declared as "Urban Historical Site"

1990 - "Conservation Master Plan" of "Urban Historical Site" was prepared by Cengiz Eruzun and Erdal Küpeli.

1992 - Restoration of Çakır Ağa Konağı was completed and the building was opened as a museum.

1996 - "Additional Conservation Master Plan" was prepared by Kamutay Türkoğlu and Ahmet Uzel.

1998 - Urban Conservation and Street Rehabilitation Project of 1. Beyzade Street, 2. Beyzade Street, 3. Beyzade Street and Aydınoğlu Agora was prepared by Fon Mimarlık LTD. ŞTİ.

2004 - 2009 Aydınoğlu Square Urban Design Project was prepared.

Taşpazarı and Demirbaba Urban Design Project prepared.

Çarşı and Esseyit Hacı Ali Ağa Fountain, Demirli Mağaza restoration projects were prepared and implemented.

2007 - Birgi Municipality was awarded a certificate of achievement by "event of Historical, Cultural Heritage and Encouragement to its Application Project"

2010 - "Revision of Conservation Master Plan" has been prepared by Ege Planlama.⁵²

As is seen, the preservation activities in Birgi had started in 70ies and increasingly continued till now.

3.3 HISTORY OF CUKUR HAMAM

As far as the building concerned, in contrast to a large number of written sources about Birgi, there is almost no written document found regarding the history of Cukur hamam.

The building is a single hamam and depending on the categorization made by Eyice this *hamam* is categorized as a *halvets* lined around a square shaped space “*kare bir mekan etrafına sıralanan halvets hücreli tip*”⁵³. The actual date of construction isn't known and inscription panel didn't remained. But because of the closeness to the Derviş Ağa Madrasa, B. G. Yavuz claims that Çukur *Hamam* was dated to the 17th century.⁵⁴ However, the foundation charters of the madrasa, never mentions Çukur hamam.⁵⁵ The architectural layout does not give a clue about the construction date. It is known that these kind of hamams is constructed between 14th and 19th centuries.⁵⁶

3.4 COMPARATIVE STUDY

The comparative study is made in three topics;

Hamams in Birgi are compared with Cukur Hamam without any limitation for the period they belong to and plan characteristic they have.

Secondly, hamams from the nearby settlements (Tire, Seferhisar, Urla, Bergama) are selected for the set of hamams to be compared with the limitation for the period they belong to 15th, 16th and 17th century hamams due to the continuity of the tradition.

⁵² F. Diri, 2010, p.55

⁵³ According to Semavi Eyice, This type is mostly constructed between 14th -19th centuries.

⁵⁴ B. G. Yavuz, 1990, p.51

⁵⁵ R. Ünal, 2001, p.131

⁵⁶ Ibid.

Lastly, hamams from Anatolia from the 15th century which have a similar plan scheme are selected to be compared with Çukur Hamam.

In terms of the resources of information, except the hamams visited, a literature research is done on hamams and bathing culture in Anatolia in general and west Anatolia in particular. In this research not only books but also thesis about hamams are searched and some of them are evaluated in this section.

- The two hamams in Birgi; which are Sasalı, and Çarşı Hamamı were visited and the necessary information is collected.
- The information of the seven hamams in Tire is taken from the Canan Çakmak's study "Tire Hamamları"⁵⁷ (2002) and the documents prepared during the study of Rest 506 course in 2008 Spring Semester⁵⁸. The information of the four hamams in Urla that are and Seferihisar region are collected from the thesis of Kader Reyhan's thesis work "Construction Techniques and Materials of the Ottoman Period Baths in Seferihisar–Urla Region"⁵⁹ (2004)
- The information for the hamams from the Anatolia is gathered from M. Yılmaz Önge's study "Anadolu'da 17th-18th Yüzyıl Türk Hamamları" (1995) and Ekrem Hakkı Ayverdi's "Osmanlı Mimarisi'nde Fatih Devri" (1989) and "Osmanlı Mimarisi'nde Çelebi ve II. Sultan Murad Devri" (1989) and Elif Şehitoğlu's "Bursa Hamamları" (2008).

In comparative study of the hamam buildings in Birgi regardless of their building period, considering only the continuity of the tradition, the hamams of recent past were examined according to their plan layouts, different sections of the hamams, heating systems, water installations, architectural elements, material use and construction techniques. In the entire Anatolia only the hamams of the same period were analyzed with respect to their plan layouts and included in the comparative study.

⁵⁷ Canan Çakmak, 2002, pp.29-82

⁵⁸ Ins. Dr.Nimet Özgönül, Res.Ass. M. N. Rifaioğlu, Serdar Saygı, Filiz Diri, Spring 2008

⁵⁹ K. Reyhan, 2004, pp. 14-113

3.4.1 PLAN LAYOUTS

3.4.1.1 SOĞUKLUK SECTION

The typological categorization was made with respect to the spatial organization. Accordingly;

- Single space
- A central space with an additional space or an iwan
- A central space with additional space(s) and iwan(s)

were the types those were distinguished.

Single Space: When *soğukluk* section is single space, generally its planned is square layout. Superstructure is usually domed but wooden roof is also being used.

In the hamams in which *soğukluk* section is covered with wooden roof a dilatation was left between the walls of this space and the masonry walls of the neighboring spaces.⁶⁰ The reflection of the superstructure in the space can be distinguished from the different thicknesses of the walls. The domed *soğukluks* have thicker load bearing walls. Even though the dome is demolished the walls are relatively intact and survived to the present day. On the other hand the walls of the wooden roofed *soğukluks* are thinner as the load they carry is lighter. In many inactive hamams these walls are demolished such as in Tire Yeniceköy Hamam.

In single space hamams the entrance door generally on the façade of the *soğukluk* which looks to the main street. In twin baths on the other hand for separating the entrances from each other, they can be located on different façades.

In terms of architectural elements, windows are observed at the upper levels of in this section. There is not a certain rule for the order the windows.

There are *sekis* along the walls of *soğukluk* space and there is a central fountain (şadırvan) located at the center of this space. Niches are used in this space in some examples. In addition; towel drying place, heart, can also be seen in some of the examples. Most of the hamams has a single space for *soğukluk* section in Anatolia.

⁶⁰ Yılmaz Önge 1995, p. 21

In some of the cases, an additional space or an *iwan* is added to the central space forming the *soğukluk* sections. Generally, the rectangular space is transformed to a square with these additional spaces. The additional spaces are covered with vaults and the central spaces with dome. İstanbul Gedikpaşa Hamamı, Karaman Sekizçeşme Hamamı, Konya Hasbeyoğlu Hamamı, and Bursa Kaygan Hamamı can be given as examples having an additional space with a central space.

For the *soğukluk* sections formed by a central space with additional space and iwan Tire Yalınayak Hamamı can be given as an example.

Due to the fact that the *soğukluk* section in Çukur Hamam is entirely demolished, there are few traces of it. However it can be deduced from the factors like the existence of the dilatation between *soğukluk* and *ılıklik*, the thin traces of the walls on the ground and the wooden roofed examples usually did not survived, that *soğukluk* was square planned and wooden roofed.

3.4.1.2 ILIKLIK SECTION

When considering *ılıklik* section; in some examples it does not exist, instead there is only an *aralık* section which is connected with service rooms.

In the examples studied, according to the spatial formation five types can be identified;

- Single *Aralık* space
- Single *Ilıklık* space
- A central space with additional space or iwan
- A domed central space enlarged with a vaulted space
- A central space with vault and an additional space

Single Aralık space

There are examples of “individual *araliks*” and “*araliks* coexisting with *ilıkliks*”. It is a transitory space where there is not any bathing activity. Besides, in the examples which *araliks* coexist with *ilıkliks*, the service rooms are connected through the

aralık section. The examples of this type of hamams are: Birgi Çukur Hamam, Birgi Sasalı Hamam, Tire Terziler Hamam, Karaman-Emir Süleyman Hamam⁶¹, Karaman-Sekizçeşme Hamam, Konya-Hasbeyoğlu Hamam, Edirne-Tahtakale Hamam Men's Section, Edirne-Sokullu Hamam Men's Section, İstanbul-İshak Bin İbrahim Paşa Hamam, Gelibolu-Saruca Bey Hamam, Bursa-Başçı İbrahim Hamam, Bursa-Emir Sultan Hamam, Merzifon-Çelebi Sultan Mehmet Hamam, İstanbul-Hoca Paşa Hamam, Edirne-Saray Hamam.

Single *ılık* Space

The *ılık* section was planned together with *aralık* section in single space hamams. Some examples are Karaman-Sekizçeşme Hamam, Edirne-Saray Hamam.

With additional space to a central space

It is composed of *halvet* cells and/or service rooms connected a square planned central space. The function of the additional space is determined by the existence of *aralık* section; in case of the *aralık* section is absent, this additional space or spaces are generally used as service rooms such as toilets, *tıraşlık*, and *keçelik*. If the *aralık* section exists than the additional spaces can be used as *halvet* like in the following hamams: Tire-Eski Yeni Hamam, Tire-Mehmet Ağa Hamam, Tire Yalınayak Hamam, Tire-Yeniceköy Hamam, Tire-Şeyh Hamam, Seferihisar-Büyük Hamam, İstanbul-Gedikpaşa Hamam, Karaman-Emir Süleyman Hamam, Konya-Hasbeyoğlu Hamam, Edirne-Tahtakale Hamam Women's Section, Bursa-Kaygan Hamam Women's Section, İstanbul-Nişancı Hamam.

A domed central space enlarged with vault;

It was observed that this model was applied in small sized hamams. In this section which provides transition from *soğukluk* to the domed part of *ılık*, *halvets* were reached through the doors which are marked by the dome. This hamams of this type are Birgi-Çarşı Hamam, Sığacık-Kaleiçi Hamam, Urla-Herzekzade Ahmet Paşa Hamam Women's Section, Bergama-Küplü Hamam, Bursa-Muradiye Hamam, and Edirne-Saray Hamam Women's Section.

⁶¹ Y. Önge, 1995, p,31

With additional space to a central space which is enlarged with vault

This type of *ılıklik* can be used individually or together with *aralık* section. Generally it is used in large sized hamams. In the existence of *aralık* section additional space is used as *halvet*. In its absence this space can become service room. The examples of this type are Tire-Molla Arap Hamam, Urla-Herzekzade Ahmet Paşa Hamam Men's Section, Urla-Kamanlı Hamam, Bursa-Kaygan Hamam Men's Section, Bursa-Atpazarı Hamam, Bursa Emir Sultan Hamam, İstanbul-Bostan Hamam, Merzifon-Çelebi Sultan Mehmet Hamamı, and Edirne-Tahtakale Hamam Men's Section.

In Çukur Hamam *ılıklik* is formed by narrow planned *aralık* section which its right side and left side are occupied with *tıraşlık* and toilets.

3.4.1.3 SICAKLIK SECTION

Sıcaklık section is the best heated place in hamam where bathing takes place. According to the sizes of hamam, it can be a collection of more than one space or a main space surrounded with *halvets* and *iwans*.

In the cases studied, four different types distinguished. These types are A, E, F and the variations of type F which are determined in Semavi Eyice's *sıcaklık* typology. In the evaluation of these hamams the types A, E, and F are the most used models.

Multi space type (F)

Except Birgi Sasalı hamam, other examples of this type are all small sized hamams. These are Birgi-Çarşı Hamam, Birgi-Sasalı Hamam, Tire-Terziler Hamam, Tire-Molla Arap Hamam, Tire-Şeyh Hamam, Sığacık-Kaleiçi Hamam, Bursa-Muradiye Hamam, and Bursa-Atpazarı Hamam.

With additional space to domed central space which is enlarged with vault type (E)

In Eyice's classification it is named as type E. This type is frequent around Birgi (Tire, Urla, and Seferihisar). In this type, *sekis* with *kurnas* upon them are posited in the spaces which are enlarged with the vaults; *halvets* are reached from the square planned and domed section. This type can be seen in Tire-Eski Yeni Hamam

Women's Section, Tire-Mehmet Ağa Hamam Men's Section, Tire Yalınayak Hamam Women's Section, Tire-Yeniceköy Hamam, Urla-Herzekzade Ahmet Paşa Hamam, Urla-Kamanlı Hamam, Seferihisar-Büyük Hamam, Bursa-Başçı İbrahim Hamam, Bursa-Kaygan Hamam Men's Section, Edirne-Tahtakale Hamam Women's Section.

With *halvet's* (having transition in between) on one, two or three sides of a central space (F)

This type of *sıcaklık* can only be seen in Çukur Hamam in and around Birgi and it was found out in the examination of the Anatolian examples that this type was rarely used in 15th century's twin baths. In this type a smaller section is used as transitory space from one or several of *halvets* around the main central to the central space of *sıcaklık*. This can be observed in Birgi-Çukur Hamam, Bursa-Kaygan Hamam Women's Section, Gelibolu-Saruca Bey Hamam, Edirne-Sokullu Hamam Women's Section, Edirne-Saray Hamam Women's Section, İstanbul-Hoca Paşa Hamam Women's Section.

With “eyvan”s and “halvet”s on one, two, three or four sides of a central space (A);

In S. Eyice's classification it is named as type A. It is frequently used in Anatolia mainly in large sized single and twin-hamams. The examples are Tire-Eski Yeni Hamam Men's Section, Tire Yalınayak Hamam Men's Section, Konya-Hasbeyoğlu Hamam, Bursa-Emir Sultan Hamam, Karaman Sekizçeşme Hamam Men's Section, Karaman Emir Süleyman Hamam, Edirne-Sokullu Hamam Men's Section, Bergama-Küplü Hamam, İstanbul-Bostan Hamam, Edirne-Saray Hamam Men's Section, Merzifon-Çelebi Sultan Mehmet Hamam, İstanbul-Nişancı Hamam, Edirne-Tahtakale Hamam Men's Section, İstanbul-İshak Bin İbrahim Paşa Hamam, İstanbul-Hoca Paşa Hamam.

According to the study of *sıcaklık* section it was found out that Çukur Hamam is under type A that is “with *halvet's* (having transition in between) on one, two or three sides of a central space”. Z05 is *sıcaklık's* main distribution space. Z09 is the transition section connecting *halvets* Z08 to Z11.

3.4.2 HEATING SYSTEM AND WATER INSTALLATIONS

3.4.2.1 KÜLHAN

Külhan is the heart of the hamam. This section where the necessary energy to heat hamam from ground is lower than the inner spaces. There is a hot water tank over *külhan* made up of copper sheet. The fire of *külhan* heats the copper sheet so that boils the water. The smoke passes under the floor of the hamam and exhausts through the chimneys inside the walls which are called *tüteklik*.⁶²

There is a big chimney making a big arch in front of the *külhan* on the outer wall of the water tank. This chimney is raised up to the level of the domes of the *sıcaklık* space to serve as utilized ventilation.⁶³

3.4.2.2 CEHENNEMLİK

The space below hamam wherein the smoke and the hot air circulates to heat hamam is called as *Cehennemlik*. Generally *cehennemlik* heats hamam underneath *sıcaklık* by smoke and hot air flowing in the tubes springing out from the water tank, however in some examples it can be seen underneath *ılıkılık*. This section is under the marble floor of upper space which is carried on stone or brick piers covered with fire resistant *od taşı*.

In Çukur Hamam according to the observations made from the openings where the marble floor cover is absent, *cehennemlik* is underneath *sıcaklık* composed of piers.

3.4.2.3 TÜTEKLİK

The pipes which are located vertically inside the walls behind the plaster are called as *tüteklik*. They are used to exhaust the smoke and the heat vertically from *cehennemlik* through the walls of the hamam.

In Çukur Hamam some of *tütekliks* were destroyed. They can be traced on the walls of some spaces. However the chimneys of *tütekliks* on the roof are absent.

⁶² K. Aru, 1949, p.35

⁶³ Y. Önge, 1988, p.412

In the examples studied it was observed that *tüteklik* chimneys were constructed higher than the level of the dome and in aligned formation.

3.4.3 WATER INSTALLATION SYSTEMS

3.4.3.1 CLEAN WATER DISTRIBUTION SYSTEM

In hamams clean hot and cold water was conducted to kurnas by plastered terracotta pipes on the surfaces of the walls.

In Çukur Hamam the hot and cold water terracotta pipes are posited one above another. Hot water terracotta pipes are set above cold water pipes and reaches to kurnas. The same system is also observed in Birgi Sasalı Hamam.

Water Tank - In the observations single space and double space water tanks were estimated. In the cases with single space water tank is used only for hot water; cold water is conducted from outside by the pipes to *sıcaklık* In cases having double space for water tank the second space is used as the cold water reservoir.

In Çukur hamam single space water tank was used and the cold water was carried from outside with pipes to *sıcaklık* via XX wall of section Z11.

3.4.3.2 WASTE WATER DISPOSAL SYSTEM

The waste water is disposed via the inclination on the floor covering or with the canals on the floor trespassing *ılıkılık* where the toilets exist.

In Çukur Hamam the marble floor covering in section Z07 was carved to form a waste water disposal canal. A similar system was also observed in Birgi Çarşı Hamam.

3.4.4 ARCHITECTURAL ELEMENTS

3.4.4.1 DOORS

In some early period hamams simply profiled cut stone depressed arches are used at the doors.⁶⁴ In later examples the area between the profiled cornice and the arched door is decorated with inscription panels and ornamentations.

According to the observations the doors of inner spaces are being closed in two ways: The first way which can be seen in Birgi Çarşı Hamam, is to close the door with a cloth cover hanged on the hooks nailed on the two upper sides of the door. The second way is wooden door wings which are adjusted to iron rings mounted to the sides of the door openings.

In Çukur Hamam since there are not any nail trace on the upper corners of the doors and the door sides are destroyed it is considered that the second method was used.

3.4.4.2 WINDOWS

In the study it was observed that there were not windows in *soğukluk* in early period hamams but in later period hamams the upper level windows were used in *soğukluks*. Since the *soğukluk* section of Çukur Hamam is demolished any trace of the windows could be followed. The only window in the Hamam is the overflow window (*taşma penceresi*) located between water tank and the section Z07.

3.4.4.3 NICHE

Niches generally used in *soğukluk* section in various size and numbers. In some hamams there are niches in *ılıklik* or *sıcaklık* to illuminate the space. In Çukur Hamam there is a niche on the south wall of Z08 in pointed arch profile.

⁶⁴ Necla Uslucan, 1992, p.118

3.4.4.4 SEKİ

In the hamams which the *soğukluk* section is demolished, it is observed that there are wide *sekis* attached to the wall where the door openings are absent. In *ılıklik* and *sıcaklık* sections on the other hand *sekis* are narrower and vary in height.

In Çukur Hamam there are high and low *sekis* determined by their traces. In *soğukluk* *sekis* are high; in *sıcaklık* section, *kurnas* are posited on low *sekis*. In comparative study in Birgi Çarşı Hamam high and low *sekis* were estimated.

3.4.4.5 KURNA

The geometrical form and sizes of *kurnas* are various. Some examples are very ornamented. Any of *kurnas* in Çukur Hamam have survived.

3.4.4.6 ŞADIRVAN

In public hamams right at the centre of changing room under the lantern at the top generally a *sadırvan* exists.⁶⁵

In the studied hamams this element was observed in Tire Terziler Hamam, Eski Yeni Hamam and in many cases in Anatolia. But in Çukur Hamam as the *soğukluk* is demolished *sadırvan* could not be seen.

3.4.4.7 FLOOR COVERINGS

In all examples studied, the floor coverings of *ılıklik* and *sıcaklık* are marble. Soğukluks are in some examples marble. In demolished *soğukluk* sections the floor covering could not be observed.

⁶⁵ Y. Önge, 1995 p. 22

3.4.4.8 ROOF COVERINGS

In hamams of this period *soğukluk* sections are covered with dome or wooden roof. In both cases the roof covering is tile. There is not any information on the superstructure of Çukur Hamam's *soğukluk*.

Ilıklık and *sıcaklık* spaces are covered with domes or vaults in accordance with the sizes of these spaces. Generally these spaces are covered with horasan plaster. In Birgi Çarşı Hamam, Tire Yeniceköy Hamam and Tire Yalınayak Hamam *ılıkık* and *sıcaklık* are covered with horasan plaster. Also in Çukur Hamam these spaces are plastered. Different than those hamams in Çukur Hamam there are stone steps springing out the dome. This situation was not observed in any of other examples.

3.4.4.9 LIGHTING ELEMENTS

Hamams require segregation due to their function, therefore the natural illumination of these buildings is provided by oculi on the superstructures.⁶⁶

Illumination in hamams is made via the lantern and upper level windows in *soğukluk*, with concave glasses mounted on the superstructure, named as *filgözü*, in *ılıkık* and *sıcaklık*. These openings can be in circular, square, polygonal or star shape. The niches which are rarely used in the walls of hamams were built to illuminate artificially the inside by candle, candelabra, or lanterns when the daylight is insufficient.⁶⁷

In Çukur Hamam which *soğukluk* is absent any trace of illumination in this space was observed.

In *ılıkık* and *sıcaklık* sections oculi are circular with diameter of 17-20 cm inside and 25 cm outside. This conic form was made by placing terracotta pipes among brick bond.

⁶⁶ Ibid. p.63

⁶⁷ S. Eyice, 1997, p.416

In the examples studied, two types of oculi construction were observed: In the first method a plain surface is produced by plaster where oculi is located. Then a circular piece of glass is inserted in the hole and fixed with plaster. In the second method there are bricks and terracotta pipes in these holes below the surface of the dome. They are inserted in with the glass bottles and fixed with plaster.

In Çukur Hamam according to the evidences on the domes the oculi were made up with glass bottles and fixed with plaster.

3.4.5 MATERIAL AND CONSTRUCTION SYSTEM

When the hamams in Birgi and around are studied, the wall construction system of these hamams is the same which is the rubble stone masonry with brick fragments. The walls are not plastered outside and plastered inside. While *soğukluk* is covered with lime plaster and coating, *ılıklik* and *sıcaklık* are plastered with horasan plaster. In hamams studied in *ılıklik* and *sıcaklık* sections where plumbing system is located the walls are coated with secondary low water penetrable plaster up to the 70-100 cm height. This plaster protects the hamam walls to the level water can reach.

All of the domes and vaults in *ılıklik* and *sıcaklık* are covered with bricks. On the vaulted superstructure of water tank stone is used as covering material. In the examples the transition elements to superstructure are tromp, pendentive and Turkish triangle.

In Çukur Hamam majority of transition elements are Turkish triangles, however there are pendentives and tromps in *ılıklik* and *sıcaklık* sections.

3.4.6 EVALUATION

According to the evaluation of the examples studied, Çukur Hamam is revealed to be exhibiting similar features with the hamams in close vicinity, with respect to material use, building technique and architectural characters of spaces. However the plan layouts of *ılıklik* and *sıcaklık* sections and the steps on the domes make it unique among others.

CHAPTER 4

RESTITUTION

Restitution has been carried out in order to assess the original physical and architectural characteristics of the building as well as the interventions the building underwent throughout its history. The restitution phase of Çukur Hamam is discussed in two stages. At first, the traces and clues coming from the building itself are identified in order to evaluate the changes at the building titles clues study. Afterwards, by evaluating the information coming from the historical study of the building, comparative study related to hamam buildings and clues study are evaluated and the intervention phases of the building are identified accordingly.

4.1 CHANGES IN THE BUILDING

Analysis on the changes in the building has been carried out in order to understand the original physical aspects of the building and the later interventions of its entire life until it comes to its current state. In order to identify these interventions; clues study is executed. The clues study identifies and highlights the questionable aspects of Çukur Hamam in terms of its façade and plan organization, architectural elements based on the comparison with different hamam buildings as well as the differentiation in material, construction techniques, details, and traces related to missing elements or inadequate construction details. For each clue a code including the clues number and which section of the hamam building it exist is given. These are mapped on the measured drawings. After the mapping of these clues coming from the building itself; together with the information coming from comparative study, historical research and clues study, the interventions that the building underwent are evaluated as additions, alterations, removals, or original which will be

the basis for the restitution study. Similar to their identifications, the evaluation of the clues is also mapped on the measured drawings.

4.1.1 CLUES

A coding is made in order to describe each clue according to its place. The coding started with "Cl" letters because the mark belongs to clues study. The second letters which can be "S", "A", "Sc", W or "K" defines the space where the clue is located. The numbers at the end is to separate the clue from the others.

4.1.1.1 SOĞUKLUK SECTION

First of all, for soğukluk section; the traces of the walls at the place of *soğukluk* section are questionable. These wall traces are parallel in between, but they are not perpendicular to *ılıklik* section (Cl S-01). Secondly, the existence of two layers of floor coverings one above the other (Cl S-02) is also questionable since in hamams there exist only one layer of floor covering. Thirdly, the terra cotta pipe going vertically at the top of the door of aralık (Cl S-03) may refer to a missing element.

4.1.1.2 ARALIK SECTION

Since the superstructure of Z01 had been collapsed, the information on the construction technique of the dome itself and the illumination holes are visible only on the remained part (Cl A-01). The connection between Z02 and Z05 is established through two doors (Cl A-02). Referring to the comparative study, the existence of these two doors connecting the same spaces is questionable since it is not suitable for the plan organizations of the hamams. In addition, the differentiation in the form and construction techniques of these two doors is also noticeable. Since there exists toilets or *tıraşlık* space within aralık section of hamams, the levelling difference at Z03 (Cl A-03) may refer to the trace of toilets in this space. Besides, the terra cotta pipe coming out vertically from the east wall of Z03 (Cl A-04) may refer to a missing element. Finally the absence of door slab (Cl A-05) is questionable since there is not a trace of it on the surrounding of the door openings.

4.1.1.3 SICAKLIK SECTION

For the sıcaklık section, the existence of a curved horizontal line of plaster at 20cm above the ground level at the north wall of Z04 (Cl Sc-01) may indicate the trace of a seki. In addition, the hole and the terra cotta pipe seen through the hole at the north wall of Z04 (Cl Sc-02) may refer to a missing tap and basin on this wall. The vertical plaster trace going vertically from *cehennemlik* to the dome at west wall of Z04 (Cl Sc-03) is also questionable. This may be a trace of a chimney that was removed later. When the comparative study on the plan organization of hamams is evaluates, the door between Z04 and Z07 (Cl Sc-04) is not suitable. Besides the differentiation of this door from the others in terms of its form and construction technique is also questionable.

The existence of a curved horizontal line of plaster at a certain level from the ground of Z05 (Cl Sc-05) may refer a missing element at this space. Similar to the clue (Cl Sc-03), the vertical plaster trace going vertically from *cehennemlik* to the dome at west wall of Z05 (Cl Sc-06) may refer to a trace of a chimney. Moreover, the door establishing the connection between Z02 and Z05 has iron installations at the (Z05 Cl Sc-07) side which might be used as a door frame.

Although the superstructure of Z06 had been collapsed, from the remaining lower part of the dome at the corners of the space (Cl Sc-08), the form and construction technique of the dome can be identified. There is an opening between Z06 and Z09 (Cl Sc-09) which might have been used as a door in time, but on the other hand the terra cotta pipes going horizontally in the wall, jars with this idea.

The terra cotta pipe and the circular hole on it at the north and east wall of Z06 (Cl Sc-10), the hole and the terra cotta pipe seen through the hole at the north wall of Z07 and the terra cotta pipe and the circular hole on it at the east wall of Z07 (Cl Sc-12) may refer to missing taps and basins on these walls. In addition, similar to the clue Cl Sc-05, the existence of a curved horizontal line of plaster at a certain level from the ground at Z07 (Cl Sc-11) and Z08 (Cl Sc-15) may refer to a missing element at these spaces.

Furthermore, the opening between Z07 and Z08 (Cl Sc-13) starts with a smooth vertical surface and continues as a half arch at west. The rest of this opening had been collapsed, but the smooth part indicates a door opening between this two spaces. The only trace that can be identified from the waste water disposal system in Çukur Hamam is the rounded canal on the marble flooring remained in Z07 (Cl Sc-14). The opening between Z08 and Z09 (Cl Sc-16) starts with a smooth vertical surface at west like the one between Z07 and Z08. The rest of this opening has been collapsed; this may indicates a door opening between these two spaces on the other hand a door between two halvets is not a suitable for the plan organization of hamams. There is a terra cotta pipe coming through the south wall of Z09 directly from outside to inside 20 cm above the ground level (Cl Sc-17). This may refer a missing element located here before.

Although the superstructure of the space Z09 had been collapsed, the transition elements still remain (Cl Sc-18). The remains of the transition elements give the information about the domed superstructure. The south and east wall of space Z11 had been collapsed with its superstructure (Cl Sc-19). At the intersection point of north and east walls the some part of the transition element remained and this gives information about the domed superstructure.

There is a terracotta pipe coming through the north wall of space Z11 (Cl Sc-20). The place of the pipe is questionable since it is a bit high to be a tap. The arch made of brick at the north wall of space Z11 (Cl Sc-21) is questionable since it may indicate a niche which was filled lately. Referring to the comparative study, stone projections from the domes of Z04, Z05 (Cl Sc-22) are questionable since they are not common elements for hamam buildings. The absence of the covering at the lightning holes (Cl Sc-23) and the absence of door slab (CL Sc-24) are also questionable since there is not a trace of it on the surrounding of the door openings.

4.1.1.4 WATER DEPOT

First of all, the circular hole at the ground of the water depot (Cl W-01) is questionable since it refers to a specific element at the heating system of hamam.

Secondly, there is a hole at the ground level of water depot (CI W-02) below the window. This hole can be a part of the hot water distribution system. There is a hole at the vault of the water tank (CI W-03) which may be for the purpose of ventilation.

4.1.1.5 KÜLHAN

For the külhan section, the wall attached to the east facade of the building (CI K-0) is questionable since according to the plan organisation of hamam, heating is done at this area.

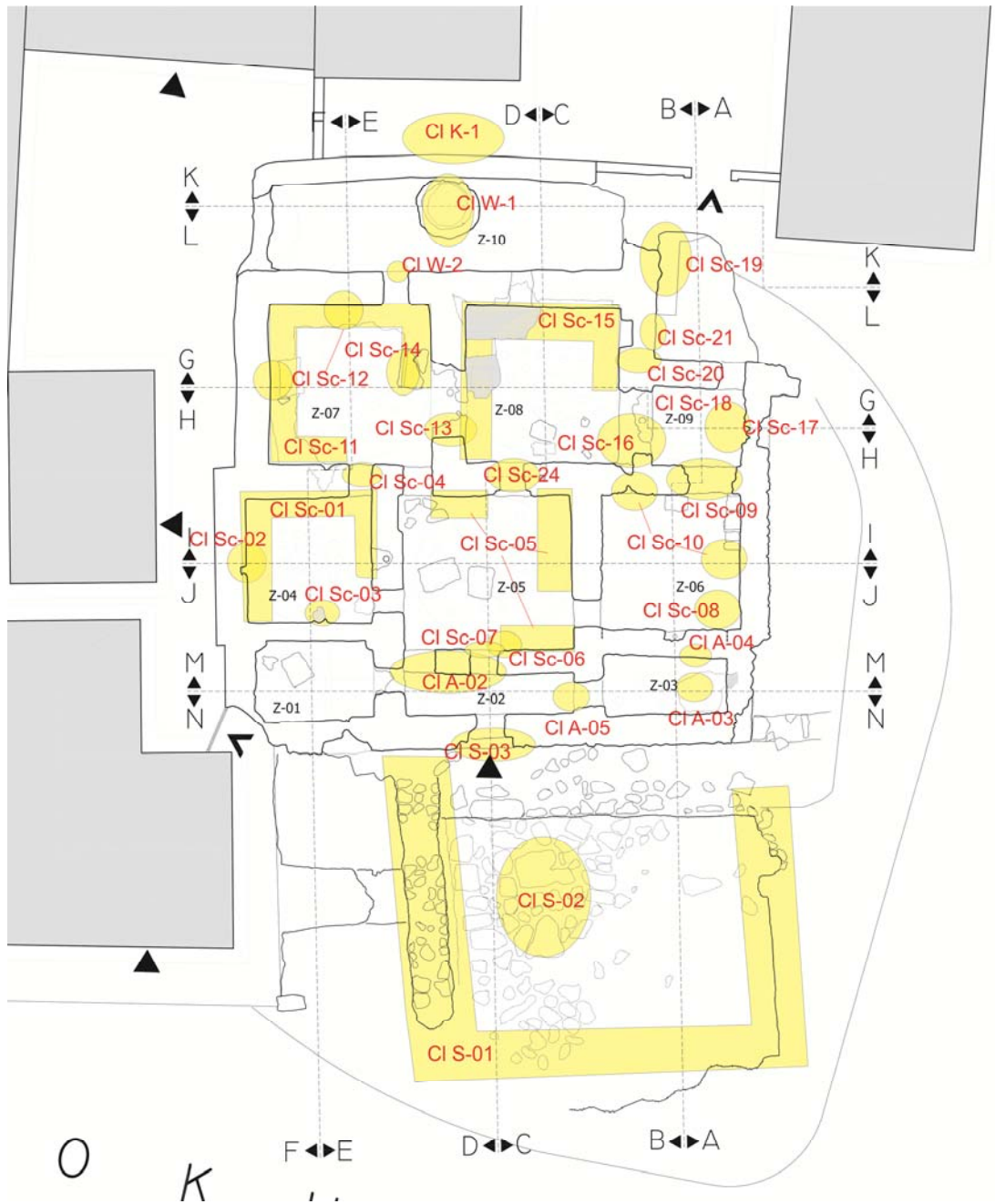


Figure 42, Clues Study; Plan

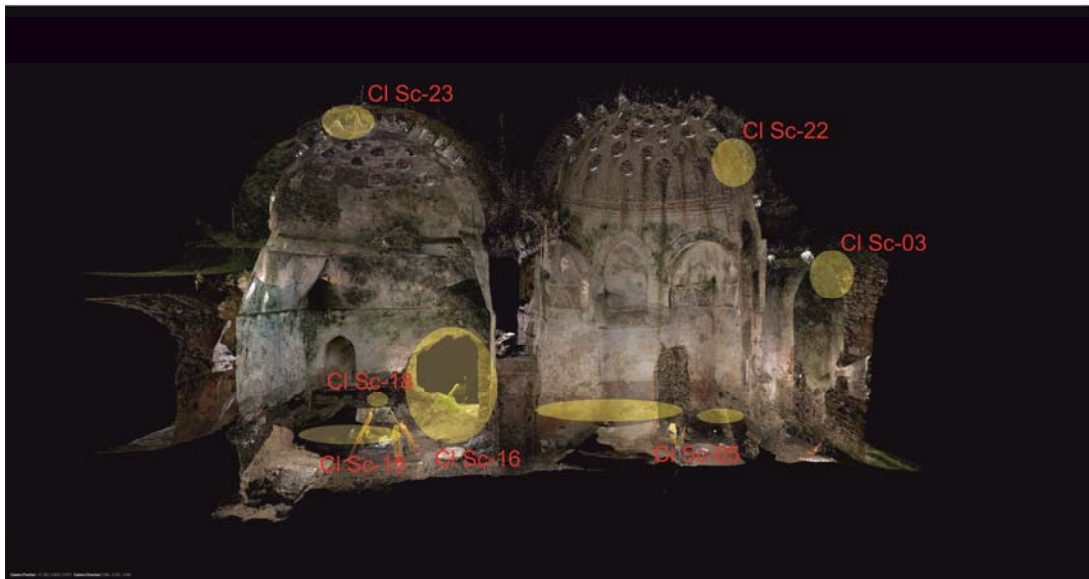
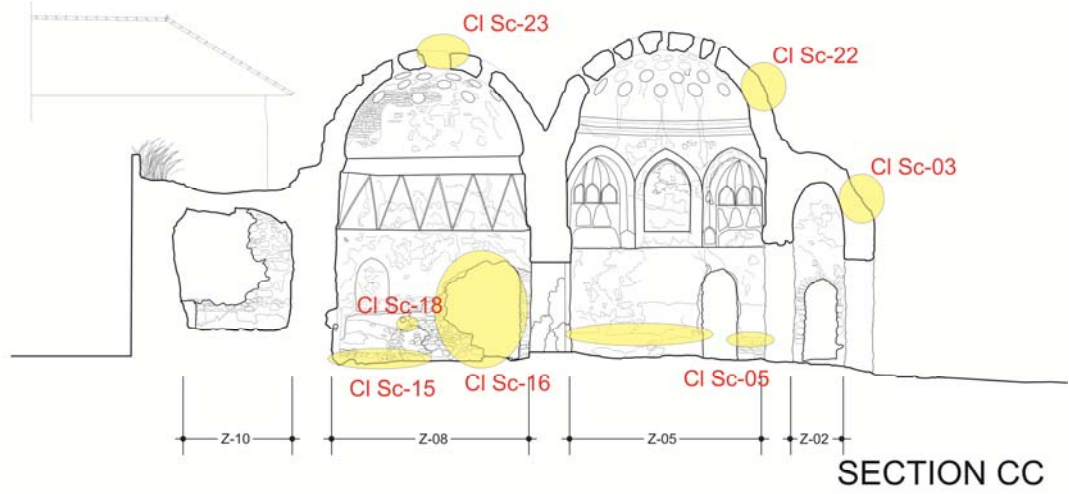
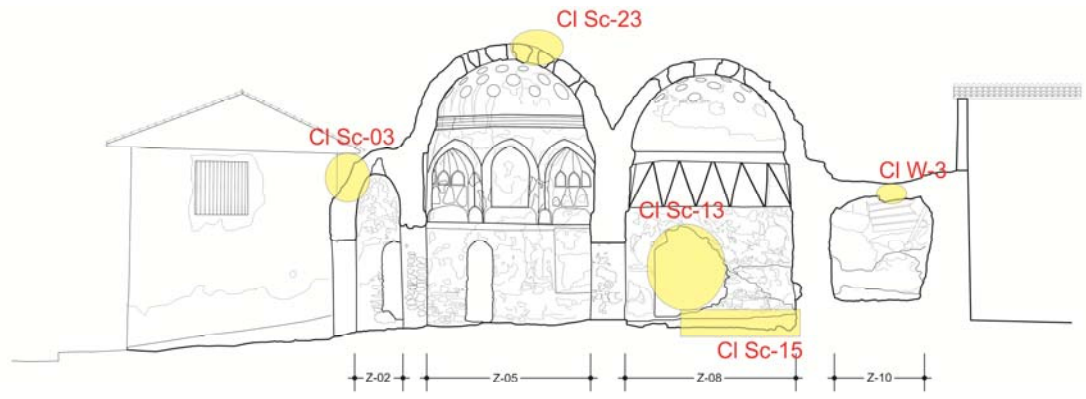


Figure 43, Clues Study; Section CC



SECTION DD

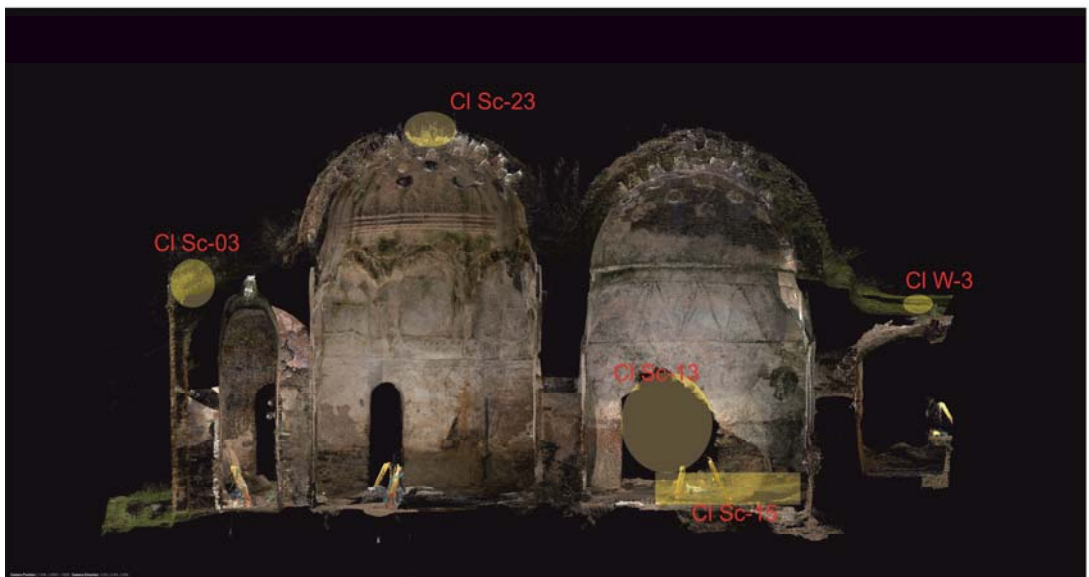


Figure 44, Clues Study; Section DD

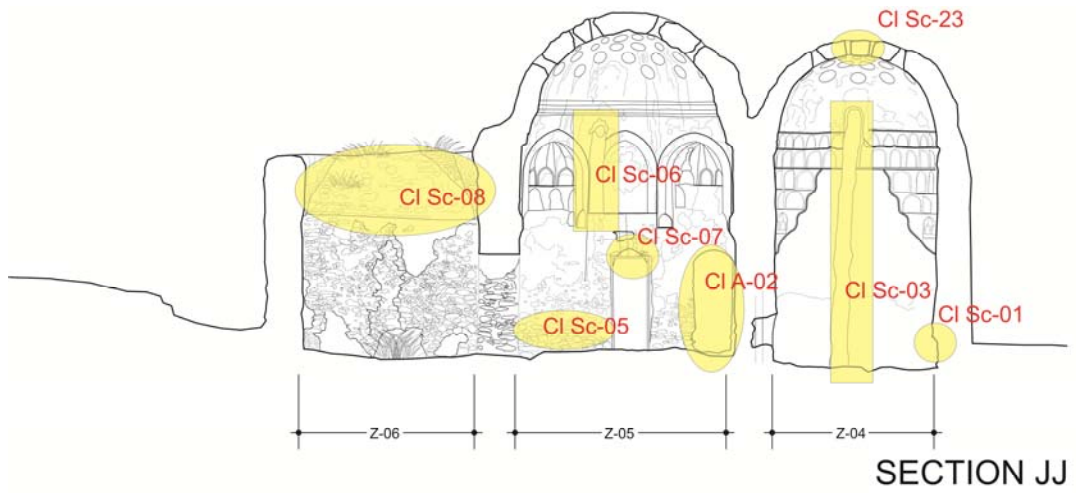


Figure 45, Clues Study; Section JJ

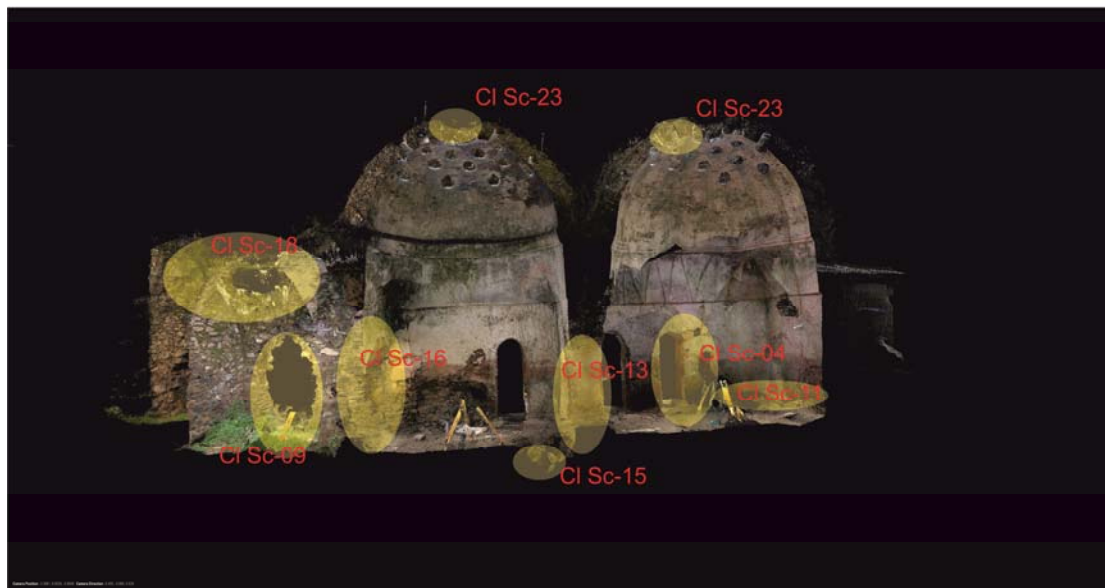
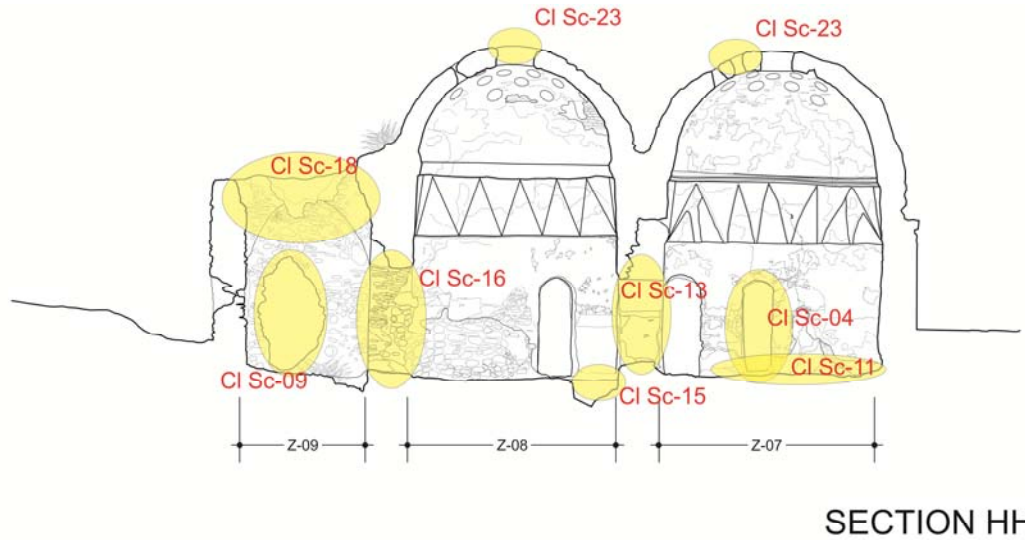


Figure 46, Clues Study; Section HH

4.1.2 EVALUATION OF CLUES

After the identification of the clues coming from the building itself, the changes in the building are evaluated regarding comparative study, comparative study within the building and historical research as additions, alterations, and removals.

4.1.2.1 SOĞUKLUK SECTION

The traces of the walls at the place of *soğukluk* section are questionable (CI S-01). These wall traces are parallel in between, but they are not perpendicular to *ılıklik* section. According to WS, at the third phase of the hamam a building was built at the

location of *soğukluk* section. The existence of two layers of floor covering one below the other one (Cl S-02) at *soğukluk* section is questionable. According to WS and T, the one below belongs to the first and second phase of the building, the one above belongs to the third phase. In addition, the terra cotta pipe going vertically at the top of the door of *Aralık* section (Cl S-03) may refer to a missing chimney. Depending on CS, a chimney was build here.

4.1.2.2 ARALIK SECTION

The superstructure of Z01 had been collapsed, some part of the superstructure remained (Cl A-01). From the remained parts, it can be said that the transition element is pendentive and superstructure is dome. Besides, the connection between Z02 and Z05 (Cl A-02) is established through two doors. The existence of these two doors at the same time is questionable since their form and construction technique is different in between. The doors which have depressed arch shape belong to second phase. In addition, the leveling difference at Z03 (Cl A-03) is questionable. This might be the trace of toilets in this space. According to comparative study, this space is used as WC and there is a toilet stone at the low leveled area. Depending on the comparative study, the terra cotta pipe coming out vertically from the east wall of Z03 (Cl A-04) refers to the trace of a tap. Besides, the absence of door slab is questionable (Cl A-05) since there is not a trace of it on the surrounding of the door openings. The edges of the door opening are damaged explains why we can't see any sign of connection element of the door slab.

4.1.2.3 SICAKLIK SECTION

Existence of a curved horizontal line of plaster at 20 cm above the ground level at the north wall of Z04 (Cl Sc-01) may indicate a *seki*. Depending on the traces coming from the building, there was a *seki* was here. Furthermore, the hole and the terra cotta pipe seen through the hole at the north wall of Z04 (Cl Sc-02), may refer to a missing tap and basin at this wall. Depending on the clues study and comparative study, there was a tap and basin. The vertical plaster trace going vertically from *cehennemlik* to the dome at west wall of Z04 (Cl Sc-03) is questionable. This may be a trace of a

chimney which was built to work like a *tüteklik*. Depending on the traces and the comparative study, at the second phase, this addition was made.

The door between Z04 and Z07 has a different form and construction technique (CI Sc-04) which is questionable. Depending on the traces and comparative study within the building, at the second phase, this addition was made. The existence of a curved horizontal line of plaster at a certain level from the ground Z05 (CI Sc-05) may refer a missing *seki* at this space. According to the traces and comparative study, there was a *seki* existing there. The vertical plaster trace going vertically from *cehennemlik* to the dome at west wall of Z05 (CI Sc-06) is questionable. This may be a trace of a chimney which was built to work like a *tüteklik* at second phase. Furthermore, the door establishing the connection between Z02 and Z05 has iron installations at Z05 side (CI Sc-07) which might be used as a door frame. This alteration was made at third phase of the building. The superstructure of Z06 (CI Sc-08) had been collapsed. But from the corners of this space the form and construction technique is observed and the lower levels of the dome had remained. The opening between Z06 and Z09 can be seen as a door opening (CI Sc-09), but the terra cotta pipes going horizontally in the wall makes this thought impossible. The terra cotta pipe and the circular hole on it at the north and east wall of Z06 (CI Sc-10) may refer to a missing tap and basin at this wall. Depending on the traces coming from the building, there was a tap and basin here. The existence of a curved horizontal line of plaster at a certain level from the ground at Z07 (CI Sc-11) may refer a missing *seki* at this space. According to T and CS, there was a *seki* here. The hole and the terra cotta pipe seen through the hole at the north wall of Z07 and the terra cotta pipe and the circular hole on it at the east wall of Z07 (CI Sc-12) may refer to a missing tap and basin at these walls. Depending on the traces, there was a tap and basin here. The opening between Z07 and Z08 (CI Sc-13) starts with a smooth vertical surface and continues a half arch at west. The rest of this opening is collapsed. The smooth part indicates a door opening between these two spaces. In addition, the rounded canal on the marble flooring remained in Z07 (CI Sc-14) can be a trace of waste water disposal system at Çukur Hamam. According to comparative study, there should be a system like this at the building. The existence of a curved horizontal line of plaster at a certain level from

the ground at Z08 (Cl Sc-15) may refer a missing *seki* at this space. According to the traces and comparative study, there was a *seki* here.

The opening between Z08 and Z09 starts with a smooth vertical surface at west like the one between Z07 and Z08 (Cl Sc-16). The rest of this opening is collapsed. The smooth part indicates a door opening between these two spaces. There is a terra cotta pipe coming through the south wall of Z09 (Cl Sc-17) directly from outside to inside 20 cm above the ground level. This may refer a basin located here before. The superstructure of the space Z09 (Cl Sc-18) had been collapsed but the transition elements still remains (pendentives). This gives information about the domed superstructure. The south and east wall of space Z11 (Cl Sc-19) had been collapsed with its superstructure. At the intersection point of north and east walls the some part of the transition element remained and this gives information about the domed superstructure. There is a terracotta pipe coming through the north wall of space Z11 (Cl Sc-20). The place of the pipe is questionable since it is a bit high to be a tap. Besides, the arch made of brick at the north wall of space Z11 (Cl Sc-21) is questionable since it may indicate a niche which was filled lately. The stones projects from the domes of Z04, Z05 (Cl Sc-22) is questionable. The stones were placed as steps for the maintenance of the domes. Furthermore, with the information coming from the comparative study, the lightening holes (Cl Sc-23) are covered with glass covering. The absence of door slab (CL Sc-24) is questionable since there is not a trace of it on the surrounding of the door openings. The edges of the door opening are damaged explains why we can't see any sign of connection element of the door slab.

4.1.2.4 WATER DEPOT

The circular hole at the ground of the water depot (Cl W-01) is questionable since it refers to a specific element at the heating system of hamam. This is the place where copper slate is covering the furnace of Külhan. There is a hole at the ground level of water depot below the window (Cl W-02). This hole can be a part of the hot water distribution system. When the hole is traced at space Z07, it is seen that the hole is connected with the pipe system in the wall. In addition, there is a hole at the vault of

the water tank which may be for the purpose of ventilation (CI W-03). In comparing with other hamams, this hole is where the space is ventilated.

4.1.2.5 KÜLHAN

The wall attached to the east facade of the building (CI K-01) is questionable since according to the plan organisation of hamam, heating is done at this area. When the Cehennemlik system is followed the place of the furnace of the külhan can be obtained. According to this the wall is constructed on külhan section of the building.

Table 2, Evaluation of Clues

	Existence	Location	Form	Detail	Material	Dimensions	Evaluation
SOĞUKLUK SECTION							
Cl S - 01	T,WS	T	WS	NI	T	WS	REMOVAL
Cl S - 02	T,CS	T	T	T	T	T	ADDITION
Cl S - 03	T,CS	T	CS	CS	CS	CS	REMOVAL
ARALIK SECTION							
Cl A - 01	T	T	T	T	T	T	REMOVAL
Cl A - 02	T,CS	T,CSB	T	T	T	T	ADDITION
Cl A - 03	CS,T	T	CS	CS	CS	CS	REMOVAL
Cl A - 04	T	T	CS	CS	CS	CS	REMOVAL
Cl A - 05	T	T	CS	CS	CS	T	REMOVAL
SICAKLIK SECTION							
Cl Sc - 01	T	T	T	CSB	CSB	CSB	REMOVAL
Cl Sc - 02	T	T	CS	CS	CS	CS	REMOVAL
Cl Sc - 03	T	T	T	T	T	T	ADDITION
Cl Sc - 04	T,CS	T,CSB	T	T	T	T	ADDITION
Cl Sc - 05	T	T	T	CSB	CSB	T	REMOVAL
Cl Sc - 06	T	T	T	CSB	CSB	T	ADDITION
Cl Sc - 07	T	T	T	T	T	T	ALTERATION
Cl Sc - 08	T	T	CSB	T	T	CSB	REMOVAL
Cl Sc - 09	T	T	T	T	T	T	REMOVAL
Cl Sc - 10	CS,T	T	CS	CS	CS	CS	REMOVAL
Cl Sc - 11	T	T	T	T	T	T	REMOVAL
Cl Sc - 12	CS,T	T	CS	CS	CS	CS	REMOVAL
Cl Sc - 13	T	T	T	T	T	T	REMOVAL
Cl Sc - 14	T	T	T	T	T	T	ORIGINAL
Cl Sc - 15	T	T	T	CSB	CSB	T	REMOVAL
Cl Sc - 16	T	T	T	T	T	T	REMOVAL
Cl Sc - 17	T	T	CS	CS	CS	CS	REMOVAL
Cl Sc - 18	T	T	T	T	T	T	REMOVAL
Cl Sc - 19	T	T	CSB	T	T	CSB	REMOVAL
Cl Sc - 20	T	T	CS	CS	CS	CS	REMOVAL
Cl Sc - 21	T	T	T	CSB	CSB	T	ALTERATION
Cl Sc - 22	T	T	T	T	T	T	ORIGINAL
Cl Sc - 23	T	T	CS	CS	CS	CS	REMOVAL
Cl Sc - 24	T	T	CS	CS	CS	T	REMOVAL
WATER DEPOT							
Cl W - 1	T	T	T	CS	CS	T	REMOVAL
Cl W - 2	T	T	T	T	T	T	REMOVAL
Cl W - 3	T	T	T	CS	CS	T	REMOVAL
KÜLHAN							
Cl W - 1	T	T	CS	CS	CS	CS	REMOVAL

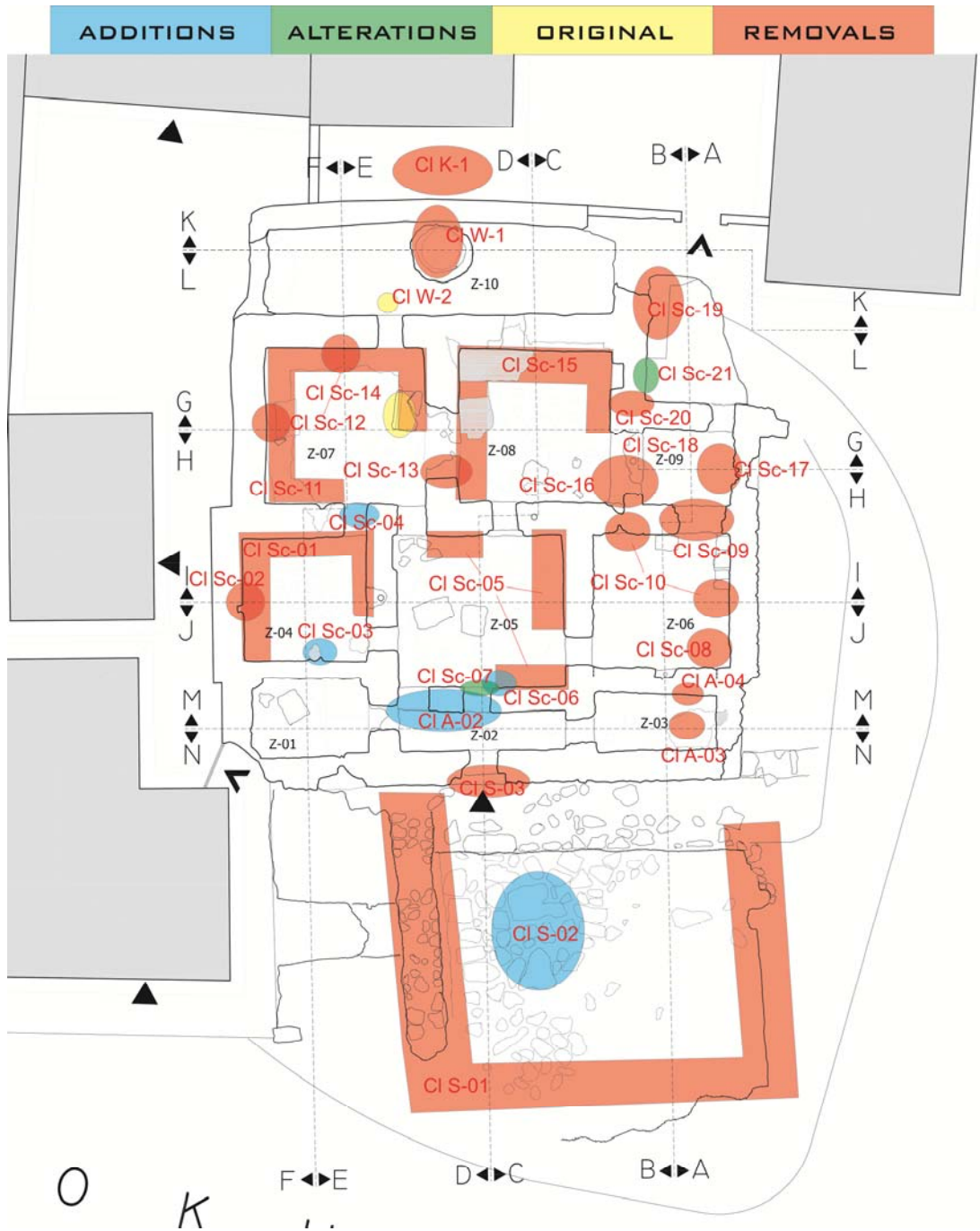


Figure 47, Evaluation of Clues, Mapping at Plan

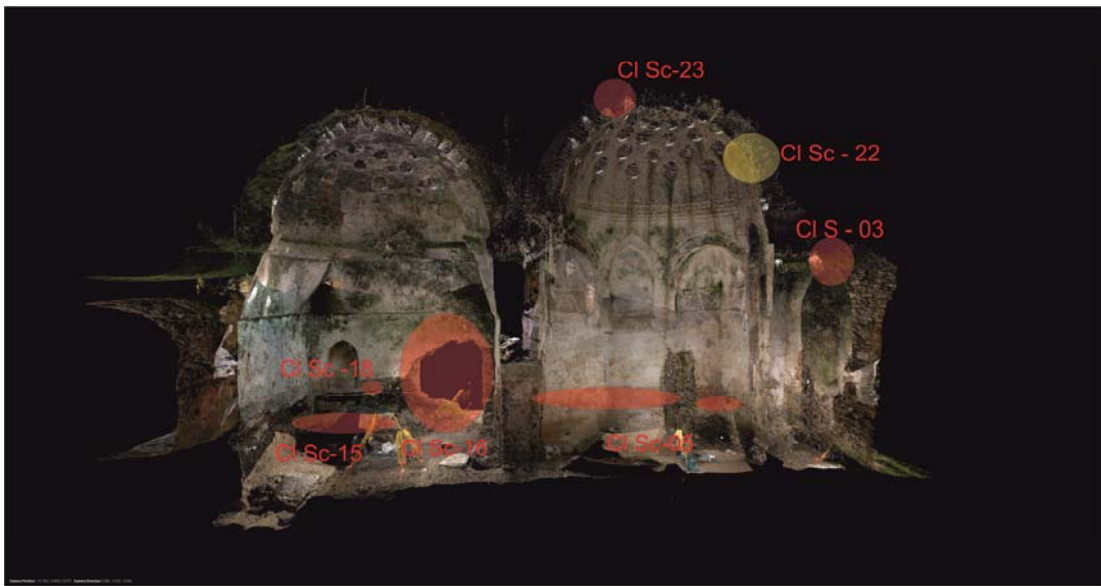
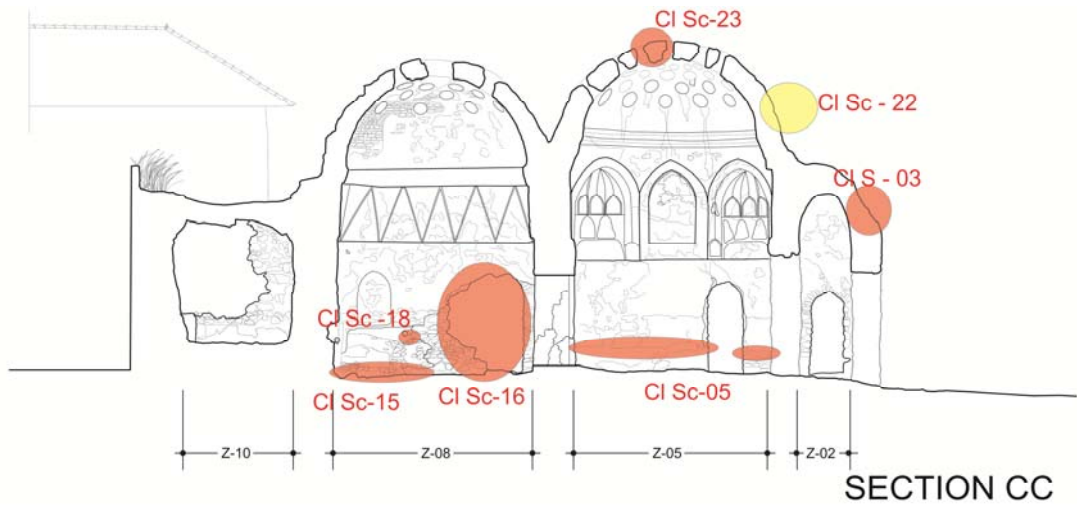
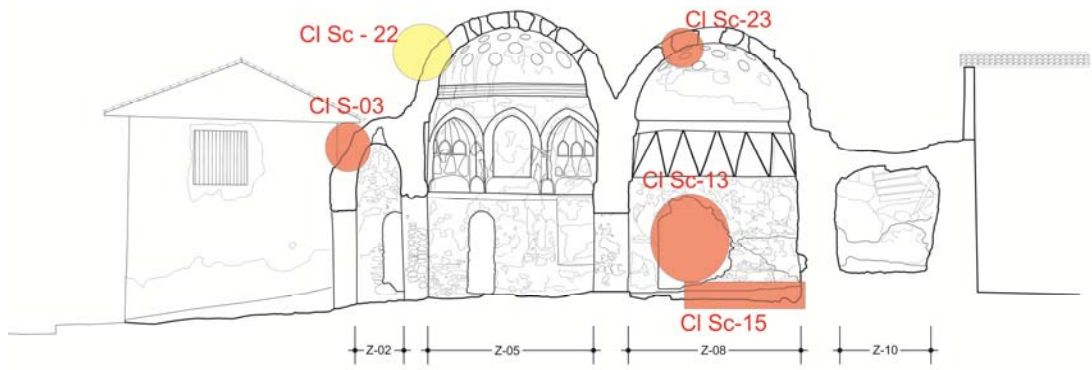


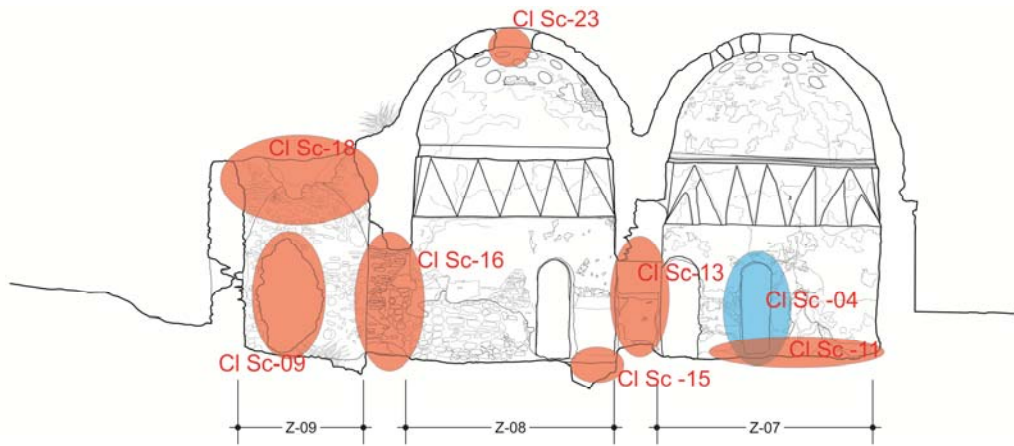
Figure 48, Evaluation of Clues, Mapping at Section CC



SECTION DD



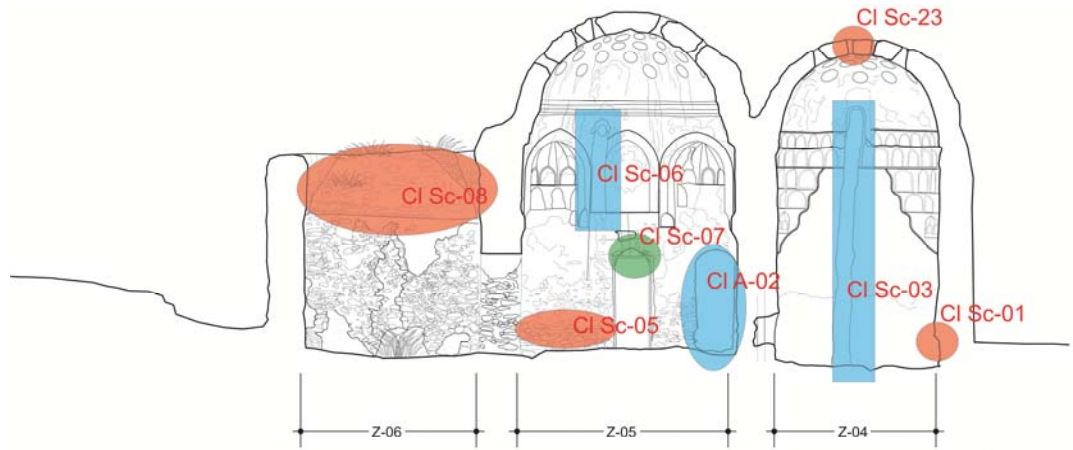
Figure 49, Evaluation of Clues, Mapping at Section DD



SECTION HH



Figure 50, Evaluation of Clues, Mapping at Section HH



SECTION JJ

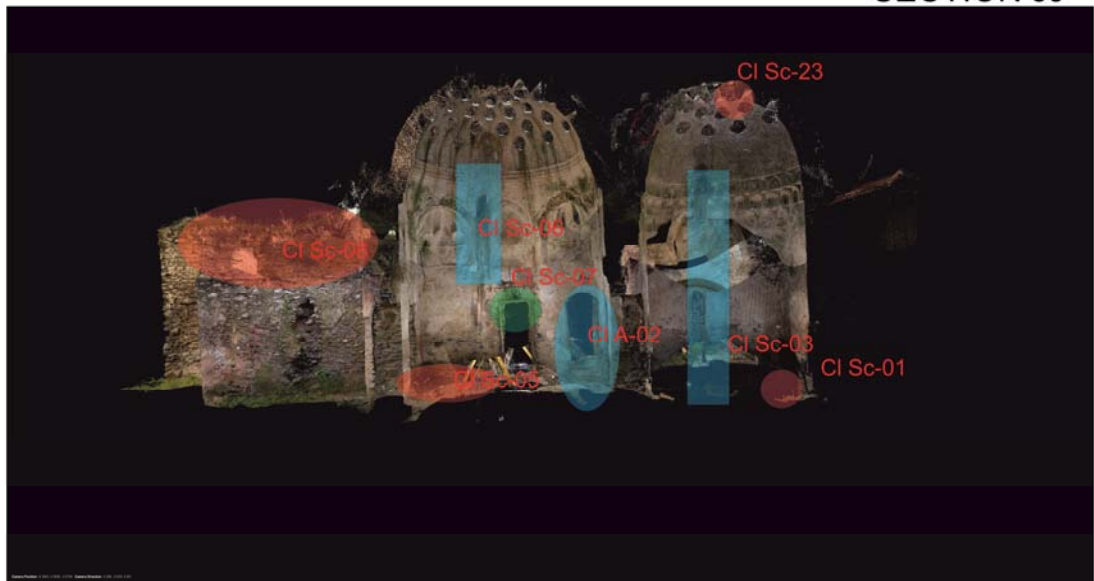


Figure 51, Evaluation of Clues, Mapping at Section JJ

4.2 RESTITUTION

Çukur Hamam has faced different interventions in time depending on the necessities of users and the building for continuing its function. However, these interventions cannot be defined as restitution periods but instead they are defined as group of interventions. With the help of the information gathered from traces of the building, historical research and comparative study, the group of interventions of the Çukur hamam are defined. According to these, two important intervention groups are defined through the historical development of the building. The exact time period of these groups cannot be defined in consideration with not having any written document about these groups and all the assessment done for defining the group of

interventions depends on the traces of the building, historical research and comparative study.

4.2.1 ORIGINAL STATE OF THE BUILDING

Original state of the building indicates the time period that the hamam had been constructed. There is no written or visual document could be reached to define the construction date, but it is estimated to be in the second half of 15th century.

The building remained in this state between the construction of hamam and the opening of new doors.

At the original state of the building, *soğukluk* which we can only see its floor today was fully intact covered with a wooden roof. It was determined that the house which is located at the north of *soğukluk* section and the other house which its courtyard wall is built on *külhan* had not been built yet. The doors which can be grouped in accordance with their forms and building techniques were determined to be belonging to two different periods. In other words, three doors which are located on the walls between Z04 and Z07, Z07 and Z08 and the northern corner of the east wall of Z02 were not exist.

The spaces Z01, Z06, Z09 and Z11 which its south and east walls now demolished were covered with domes at the original state.

The *sekis* in the spaces Z04, Z05, Z06, Z07, Z08 and Z11 which only their traces left were intact in this period and *kurnas* which are not present and followed by their traces on walls were active and located on *sekis* .

The marble floor cover which can only be observed on the corners of the wall junctions was covering the all spaces in this period.

The outer façade of the building was not plastered while the inner spaces were plastered.

4.2.2 FIRST GROUP INTERVENTIONS

The new doors between spaces were constructed while the first group interventions applied to the building. The door at the north corner of the east wall of section Z02, and the doors linking the sections Z04 to Z07, Z07 to Z08 were added.

It is considered that in this period, hamam had heating problems. Because of this reason additional *tütekliks* attached on the west walls of Z04 and Z05.

4.2.3 SECOND GROUP INTERVENTIONS

Before the second group interventions were done, the building has already lost its hamam function. *Soğukluk* section was demolished and a house was built over there. The marble floor coverings of inner spaces were removed to be used in the floor of the new house. Kurnas in *halvets* also must have been removed in this period.

4.2.4 EVALUATION OF INTERVENTION GROUPS

The building was faced two intervention periods and lost its function in the second period. The devastations increased after the second group interventions. Actually there is not much intervention to the building except the demolition of *soğukluk* and *külhan*. Therefore without using many sources, by following the traces on the building the periodisation can be made.

Consequently, the building without exposing to important changes (portable elements such as *filgözü*, *kurnas* and door wings) survived to present time. Spatial features of *soğukluk* and *külhan* is unknown.

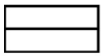
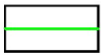
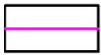
ORIGINAL STATE OF THE BUILDING	
FIRST INTERVENTION GROUP	
SECOND INTERVENTION GROUP	

Figure 52, Legend of Restitution Drawings

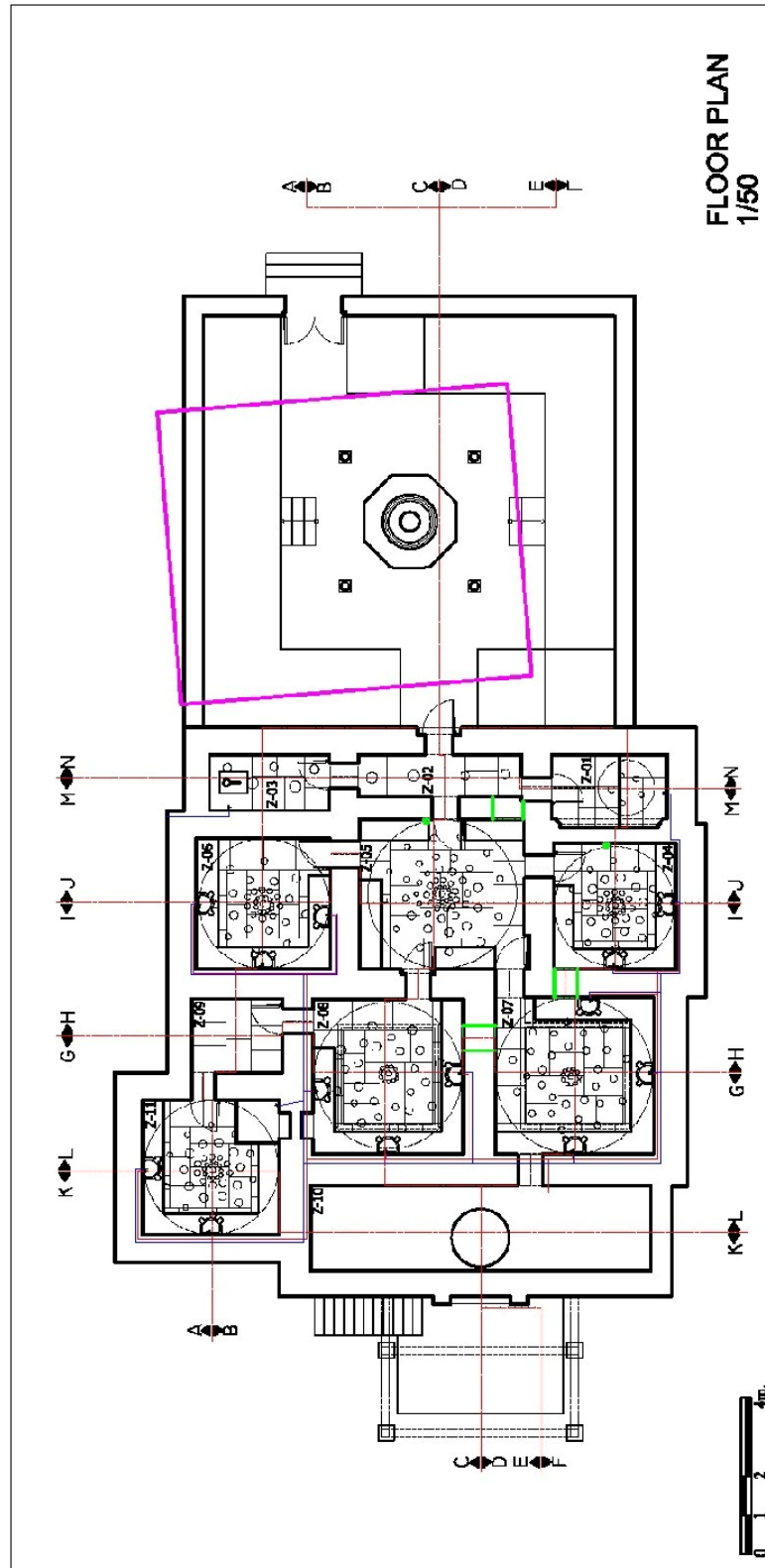


Figure 53, Restitution Drawings; Floor Plan

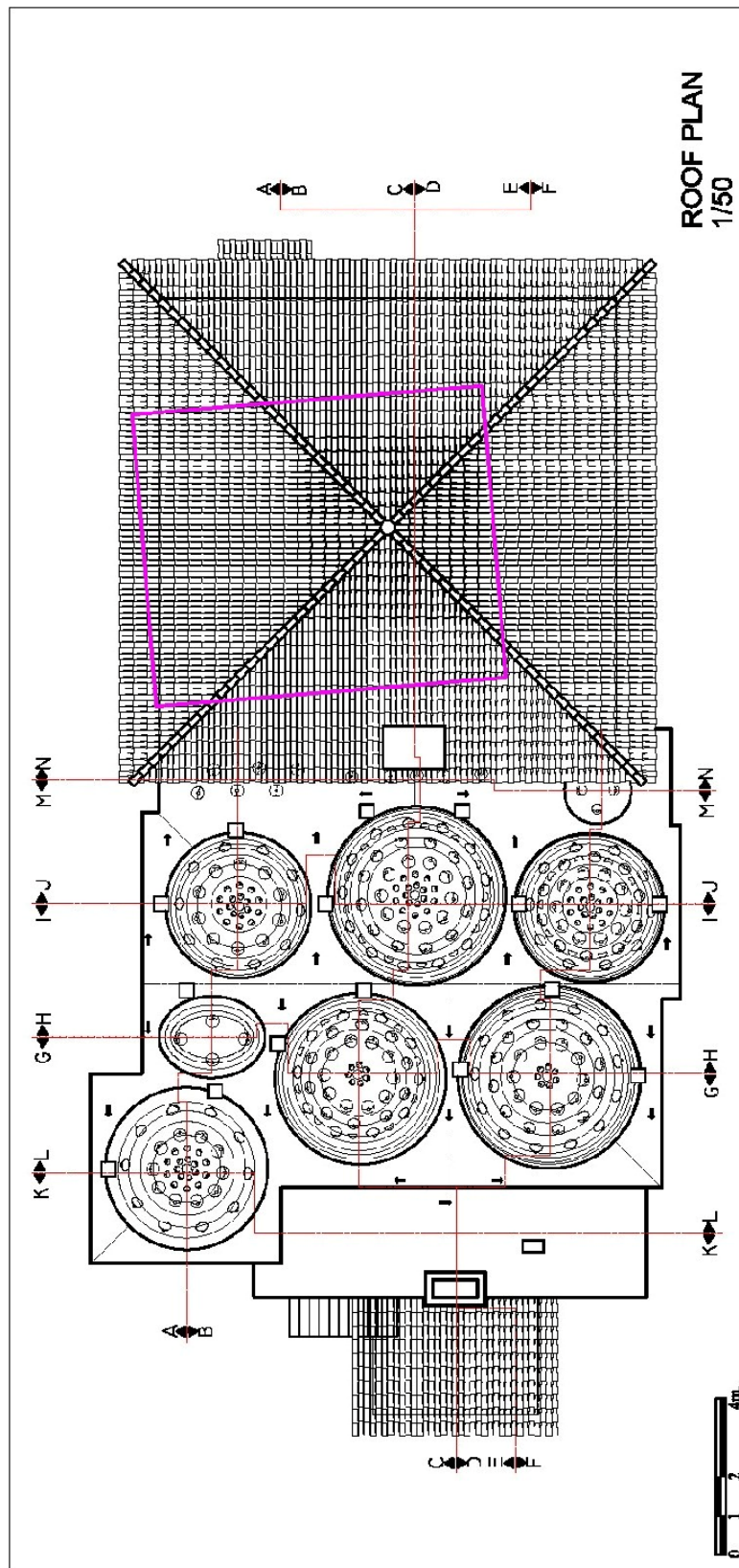


Figure 54, Restitution Drawings; Roof Plan

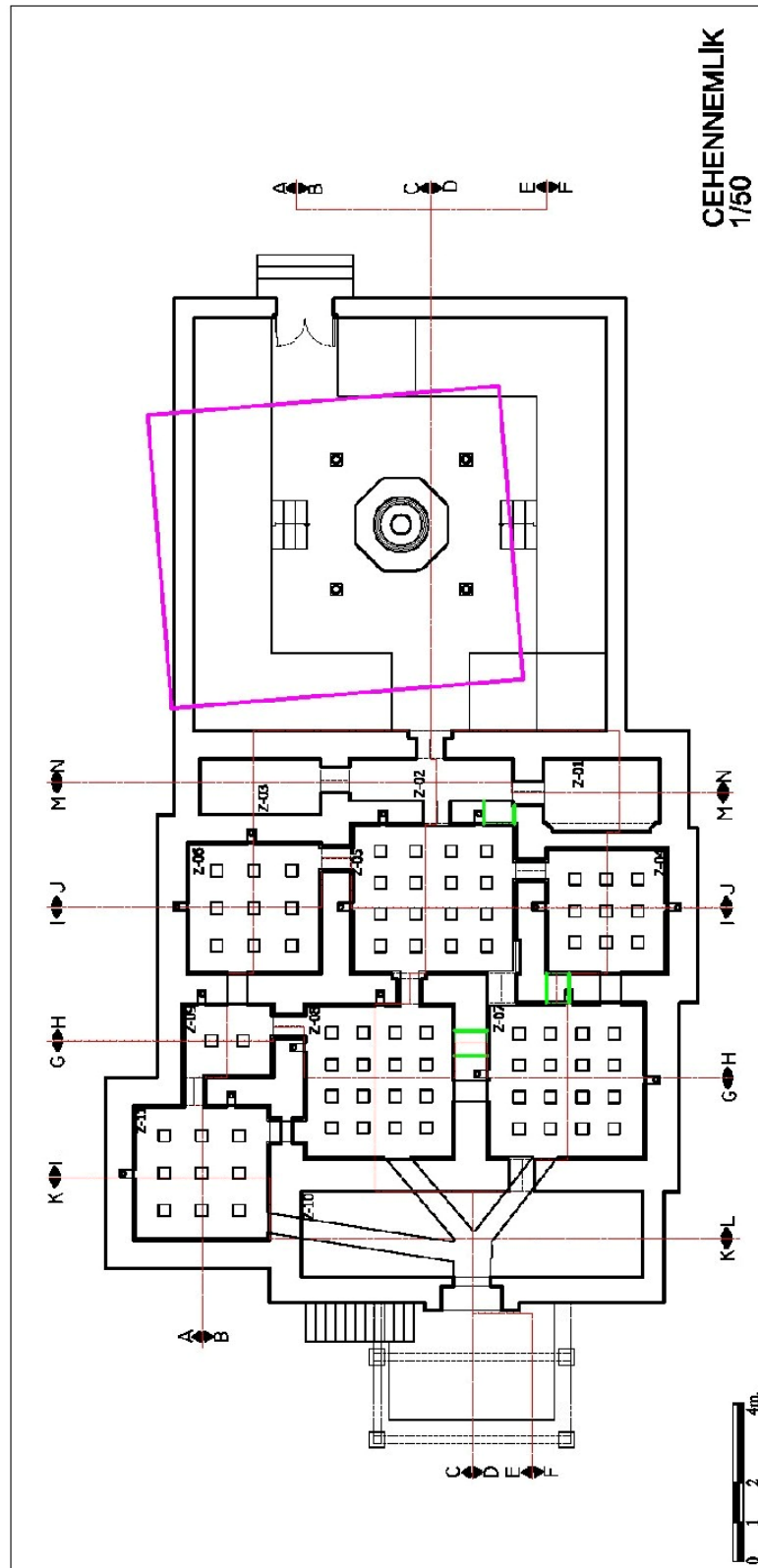


Figure 55; Restitution Drawings; *Cehennemlik* Plan

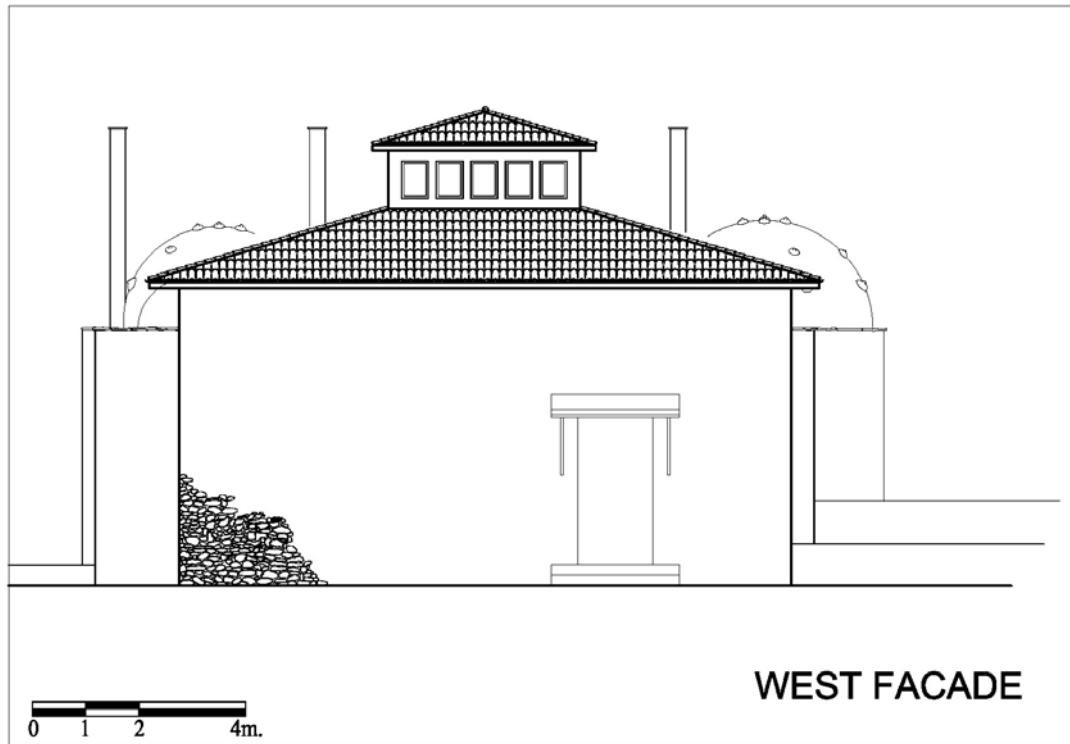


Figure 56; Restitution Drawings; West Facade

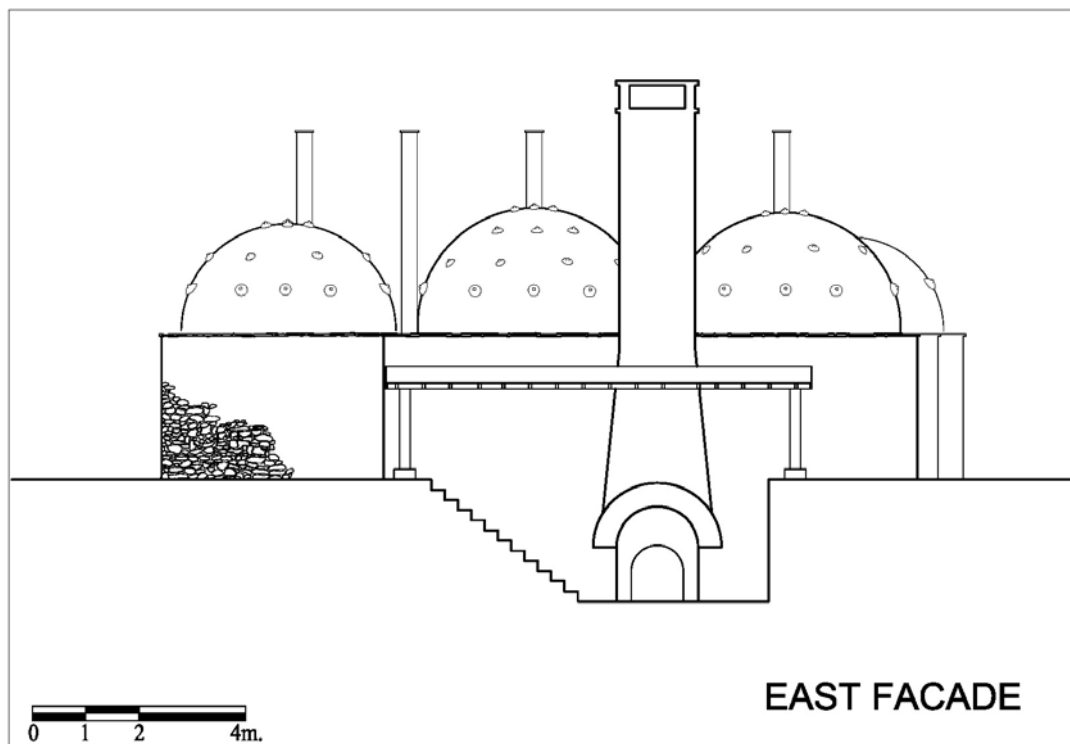


Figure 57; Restitution Drawings; East Facade

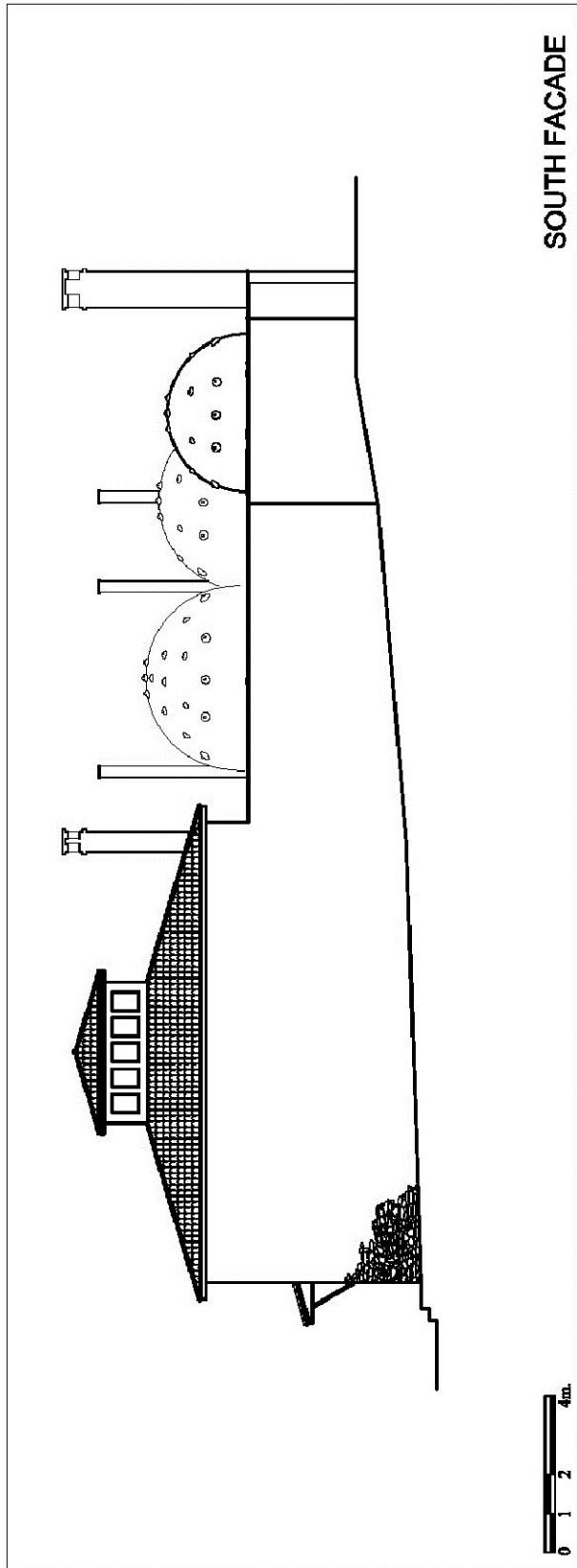


Figure 58: Restitution Drawings; South Facade

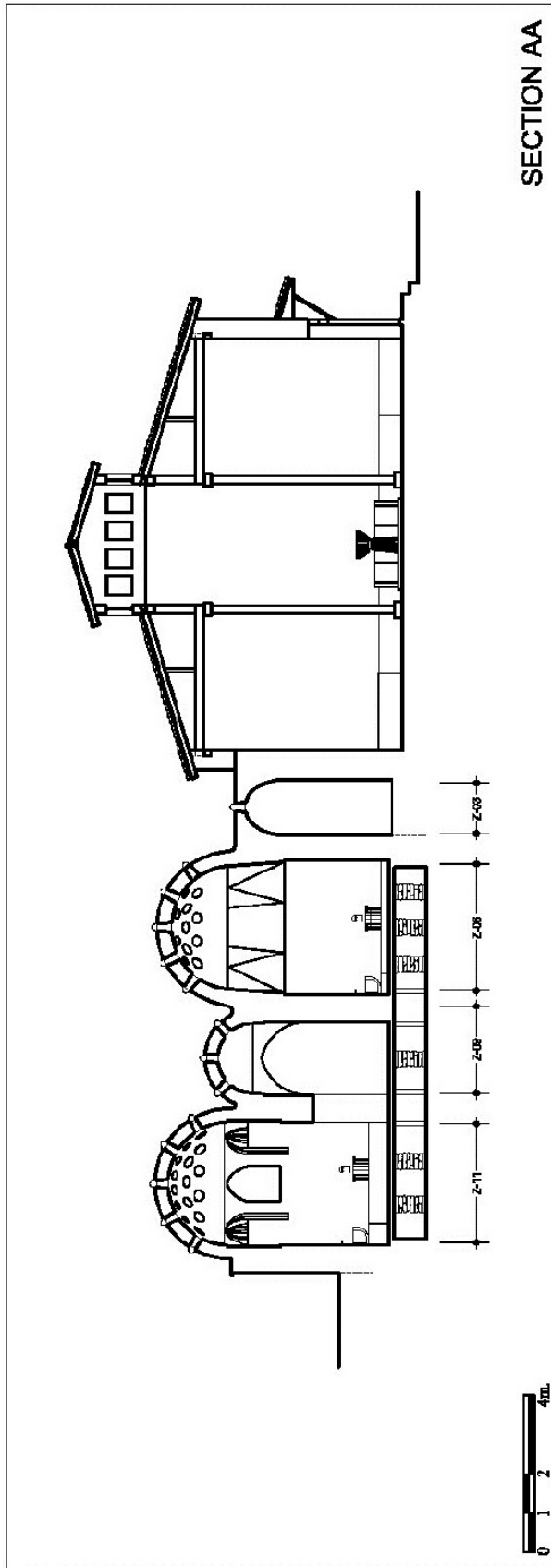


Figure 59; Restitution Drawings; Section AA

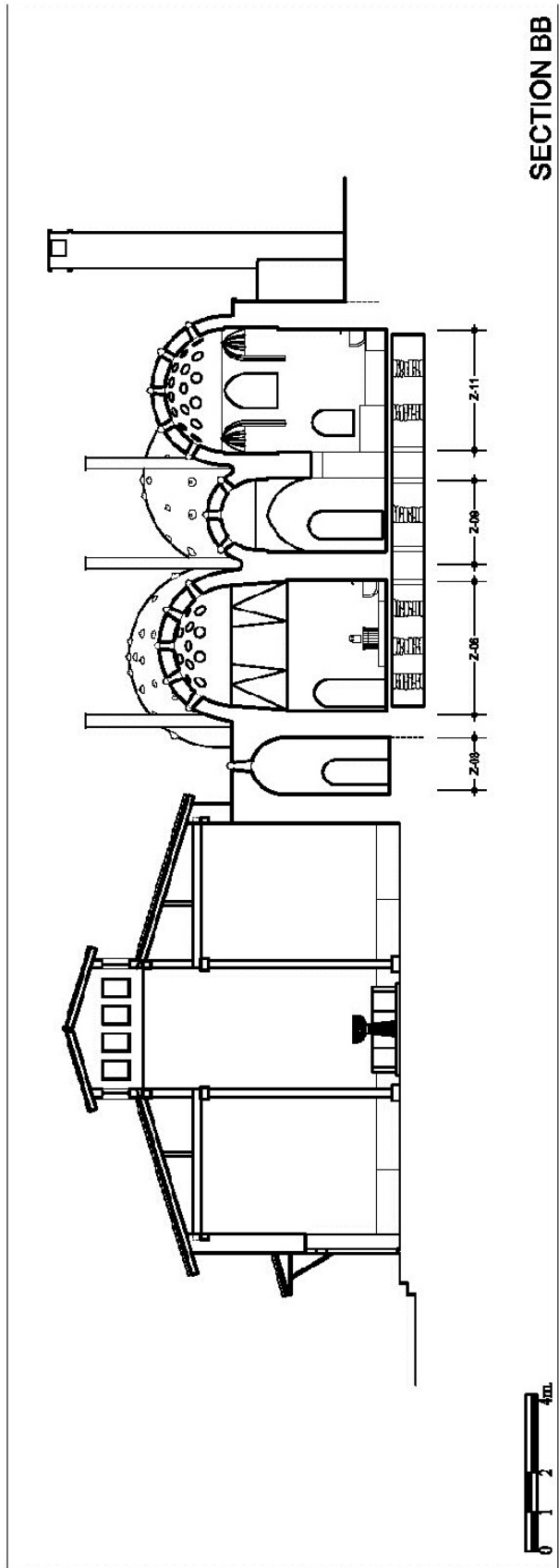


Figure 60; Restitution Drawings; Section BB

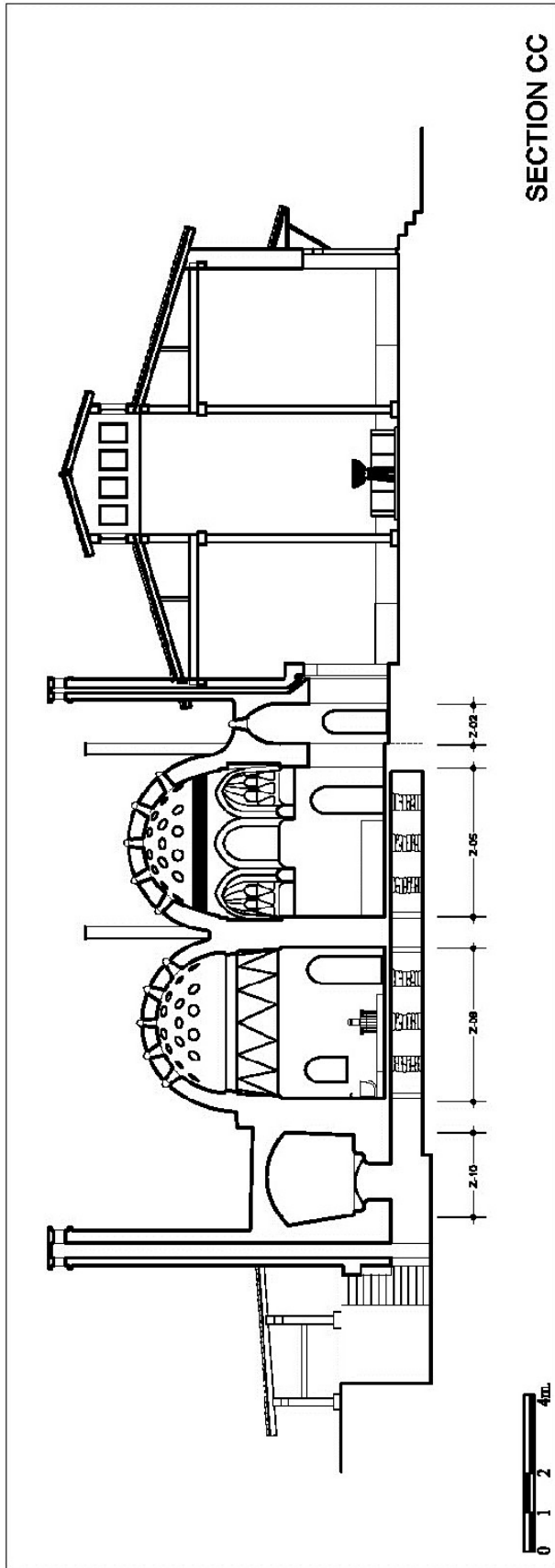


Figure 61; Restitution Drawings; Section CC

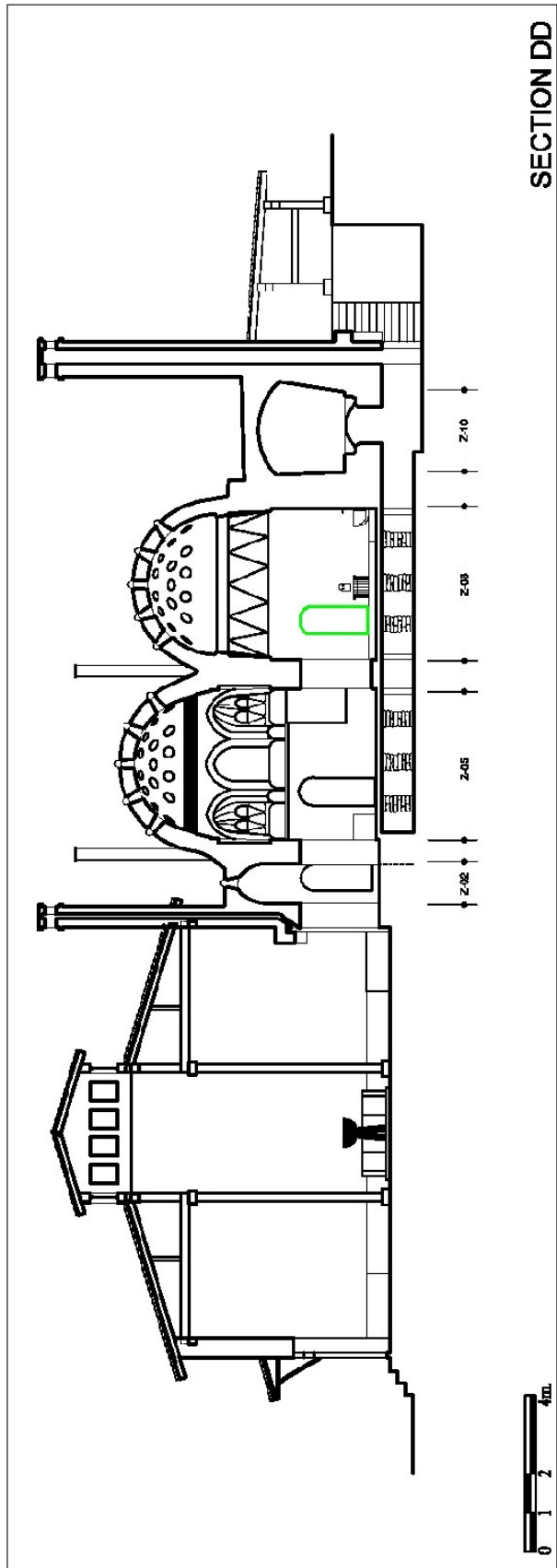


Figure 62.; Restitution Drawings; Section DD

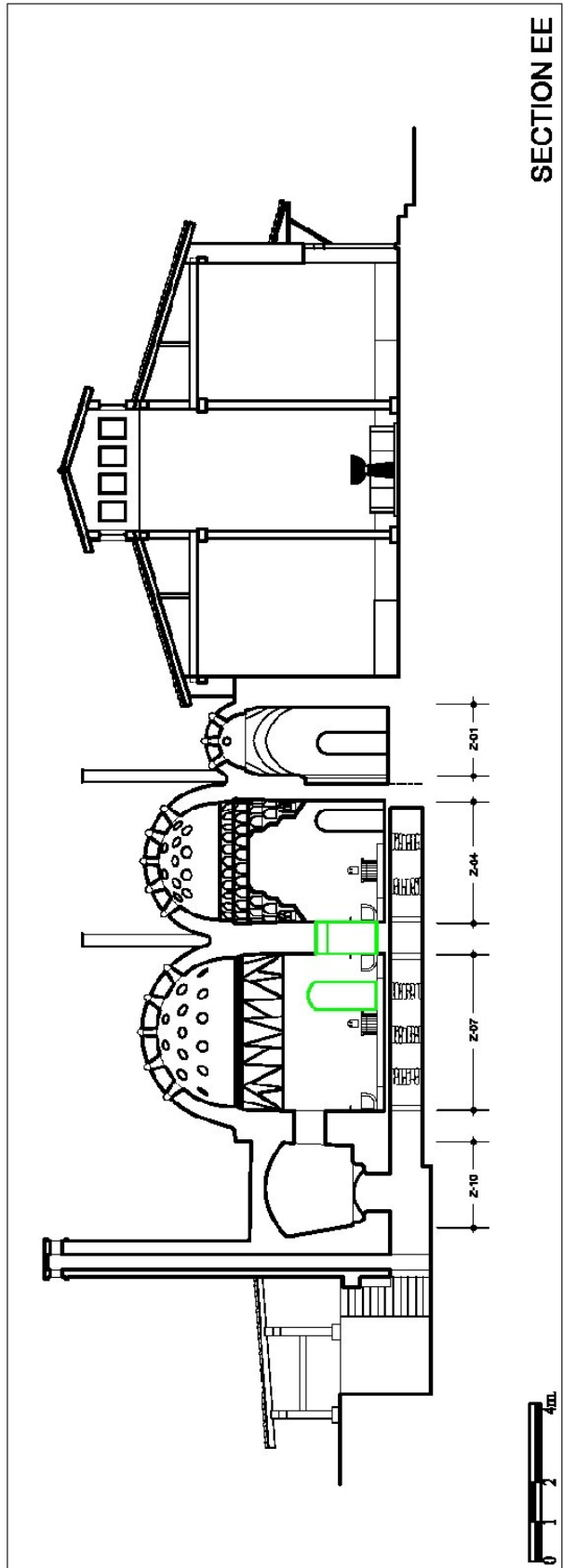


Figure 63; Restitution Drawings; Section EE

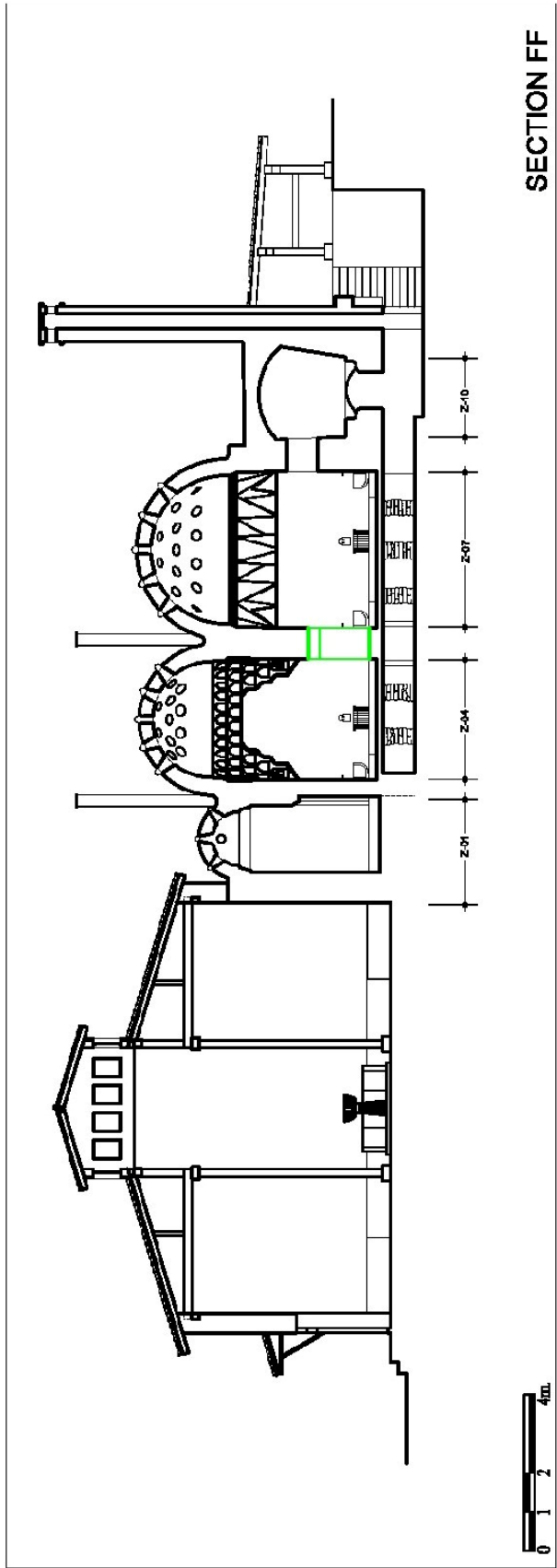


Figure 64; Restitution Drawings; Section FF

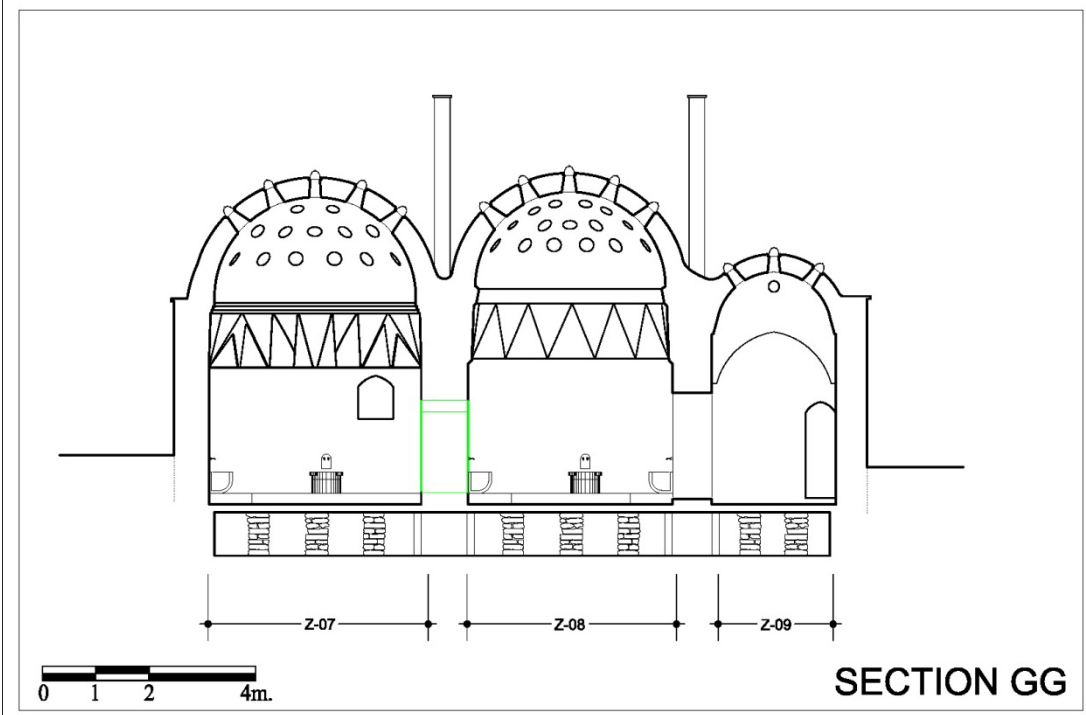


Figure 65; Restitution Drawings; Section GG

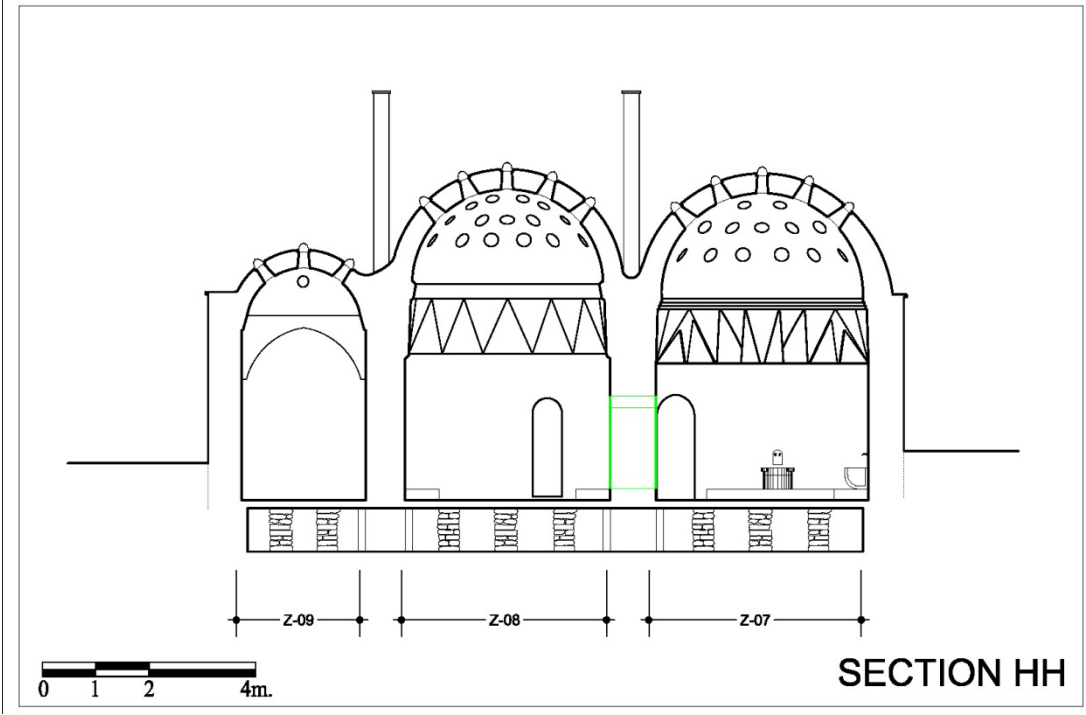


Figure 66; Restitution Drawings; Section HH

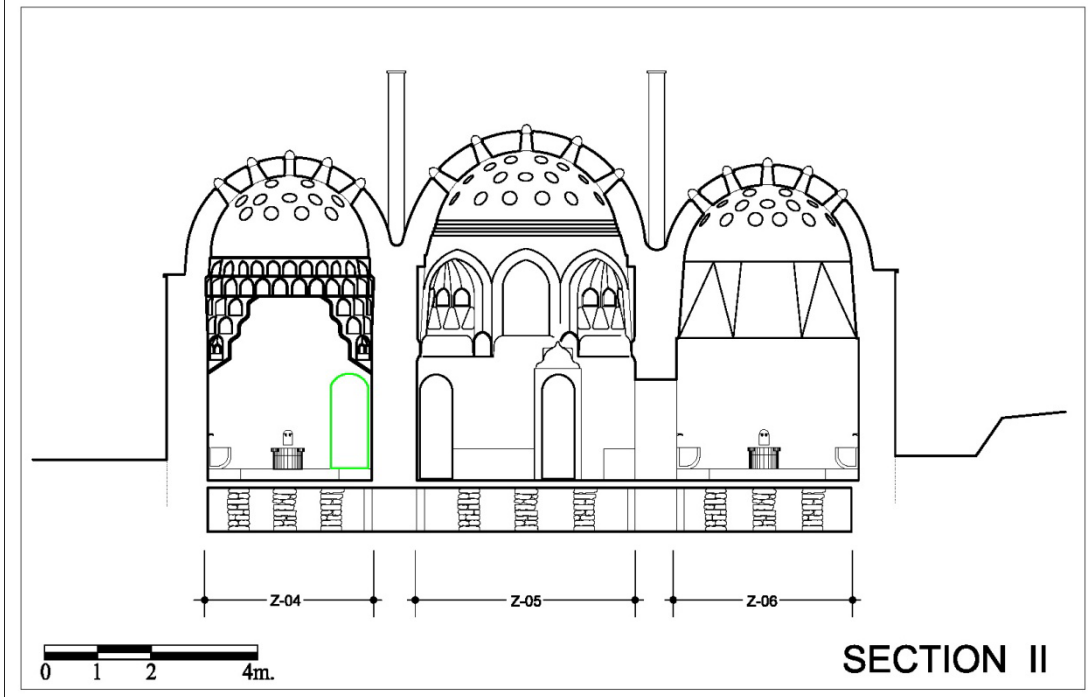


Figure 67; Restitution Drawings; Section II

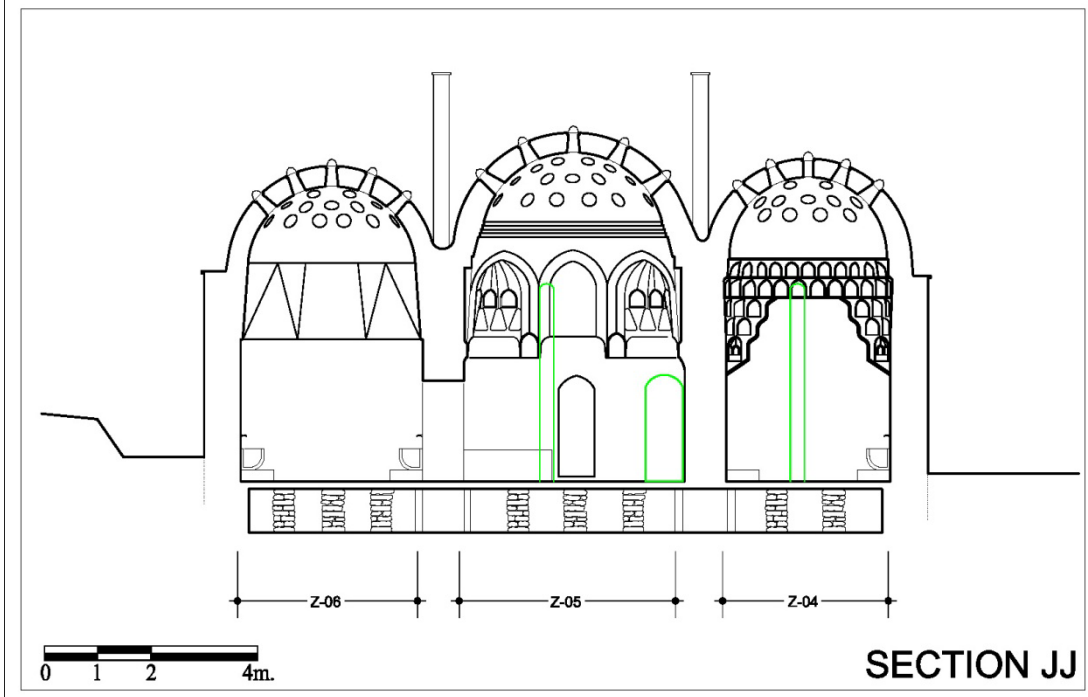


Figure 68; Restitution Drawings; Section JJ

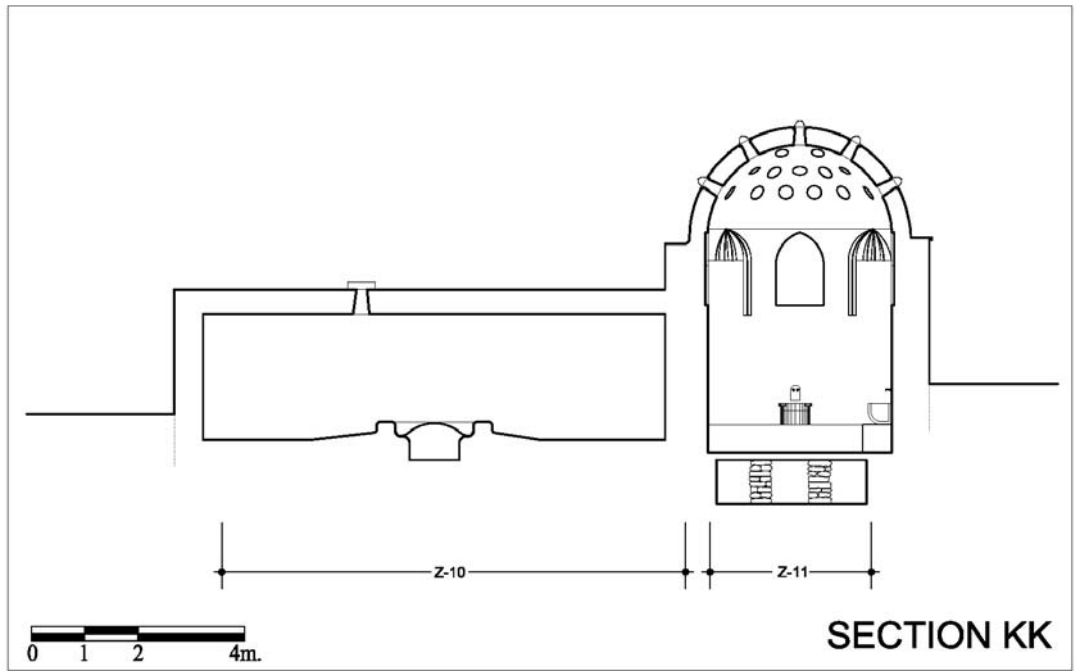


Figure 69; Restitution Drawings; Section KK

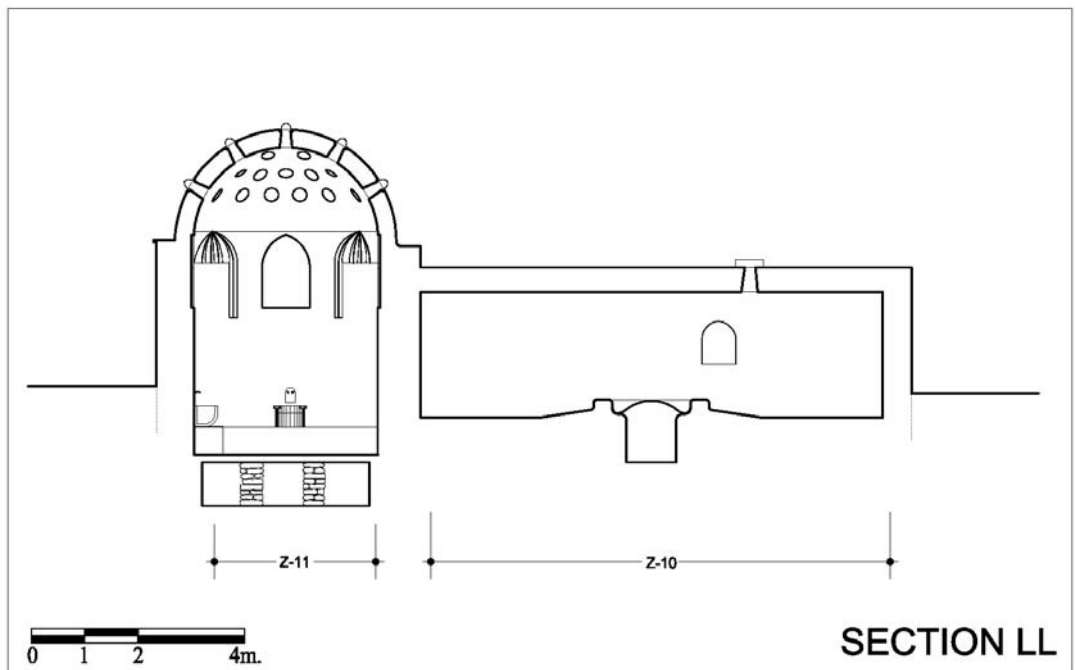


Figure 70; Restitution Drawings; Section LL

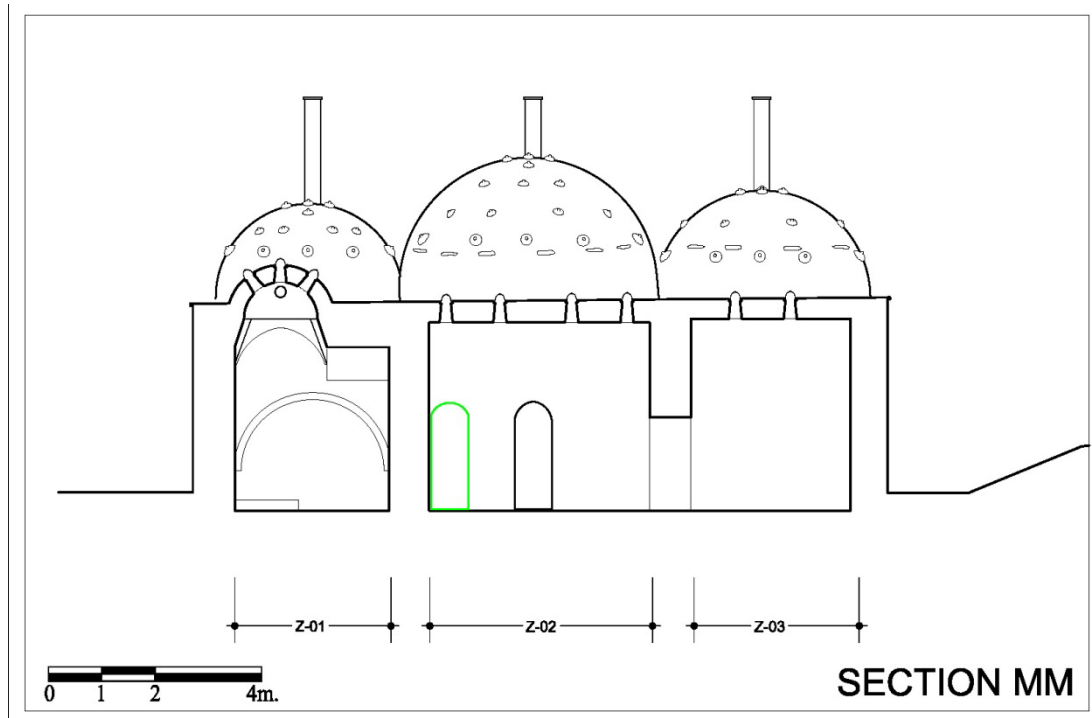


Figure 71; Restitution Drawings; Section MM

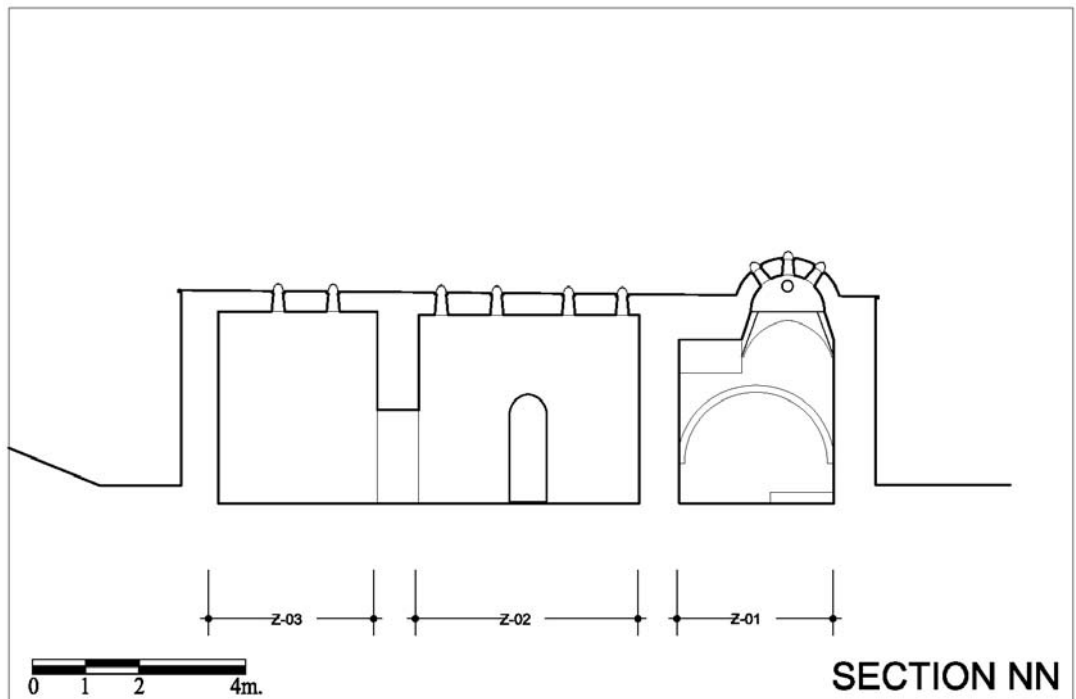


Figure 72; Restitution Drawings; Section NN

4.3 RELIABILITY OF THE RESTITUTION

The reliability degrees of the changes in the building have been graded under four groups. The first degree reliability is identified as; the existence, location, form and details can be evaluated from the remaining parts or the traces of the elements. Second degree is defined as the existence and location of the element can be understood from the traces of the element. Forms or details of the element can be gathered from the comparative study within the building. Third degree reliability is identified as the existence and location of the element can be understood from the traces of the element. Forms and details of the element can be gathered from the comparative study in the nearby environment. Finally, the fourth degree is defined as the existence and location of the element is known, but the other specialities of the elements are not known.

CHAPTER 5

RESTORATION APPROACHES

This chapter consists, evaluations of the town, building environment and the building. Values, problems and potential evaluations are also done in this chapter. Study is ended up with presentation of a restoration project proposal which is containing only the interventions related to the new function.

The evaluation for restoration approach is done in three scales; town, building environment and building. The evaluations are made in three titles values, potentials and problems.

The evaluation of the town and building environment are done together. Within the study of town, the location of the town, closeness to the other historical sites and touristic centres, the historical background, the behaviour of the local administrative governors, the building pattern and their association with the hamam are discussed.

For the evaluation of the hamam, intrinsic and extrinsic values are defined with the contemporary usage values. The spaces and area that the hamam is located are examined in terms of potentials. Problems regarding the building and the environment that the hamam situated are discussed in this section.

As a result of these evaluations, general principles of the restoration project are estimated. The principles of the restoration project are defined in three categories; principles related to conservation, principles related to historical phases and principles related to new function The types of interventions that are based on these restoration principles.

5.1 EVALUATION OF THE TOWN

Birgi is no longer a passageway for the region and as it is not close to the highway, it is hard to reach the town easily. (See location of the building in introduction.)

When the historical background of the town is evaluated, Birgi has a rich historical background and the history of the town can be observed from the buildings which maintains the continuity of the history also around Çukur Hamam..(See historical research)

With the help of the latest legislation, the increasing restorations triggered the cultural tourism which effected the inhabitants of Birgi. With this effect the people living in Birgi started to have a conservation consciousness.

Derviş Ağa Madrasa and Çukur Hamam should be evaluated together due to their extant authenticity.

5.2 EVALUATION OF THE BUILDING ENVIRONMENT

Cukur hamam is located near a ruin of mill and in front of Dervis Aga Madrasa at Okul Street. In addition to that there are traditional residential buildings showing the social and cultural features of daily life of past. Therefore Cukur hamam and its surrounding reflect the life of inhabitants living in Birgi with their social and cultural aspects. On the other hand, the residential buildings beside Cukur Hamam at north and East which are constructed recently are inharmonious with the pattern and destroy the unity of Hamam. The road being used to reach to hamam is destroyed; the road from the main avenue which is made up of interlocking paver becomes tarmac at the middle of the street.

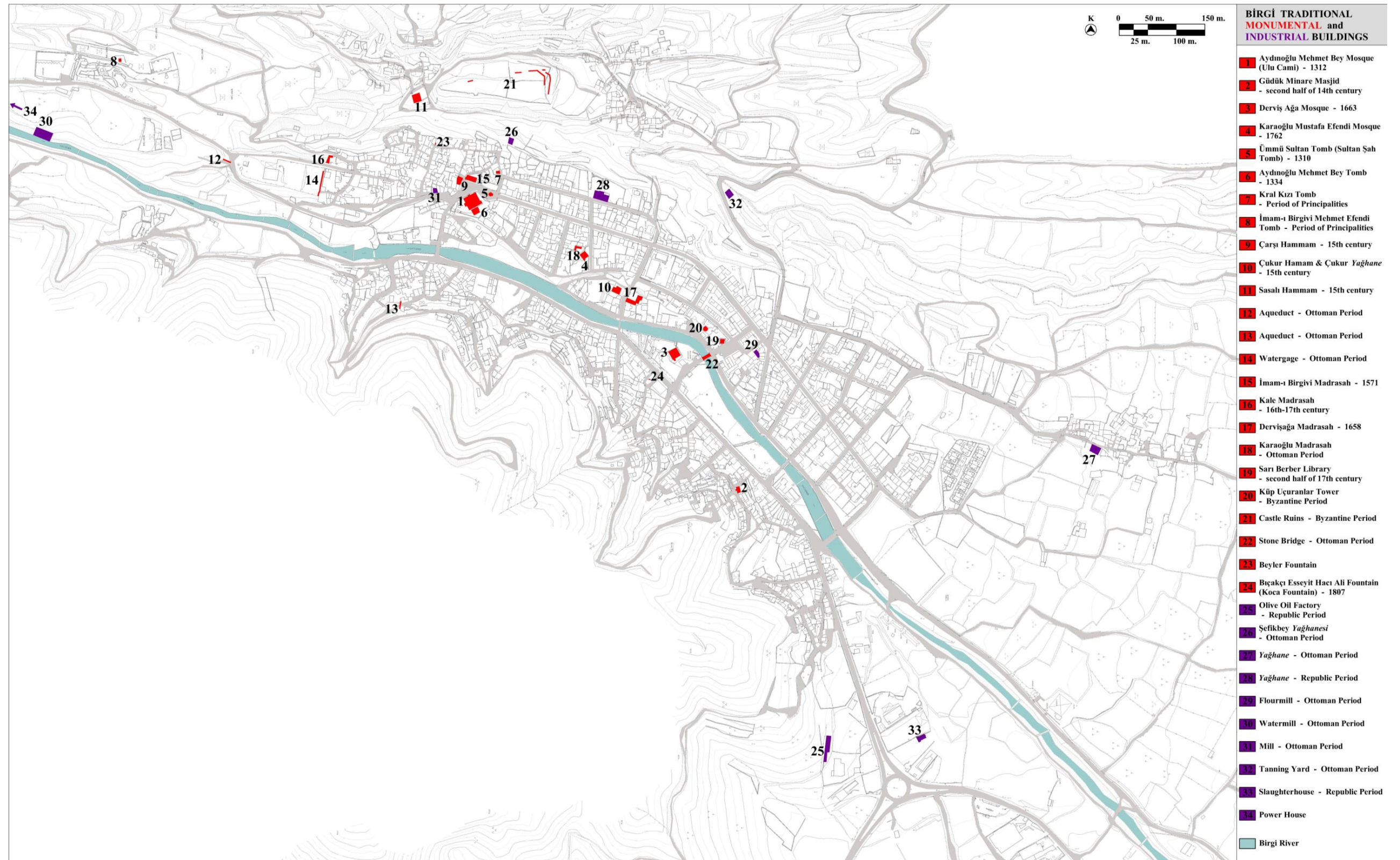


Figure 73, Historical Monumental and Industrial Buildings⁶⁸

⁶⁸ Filiz Diri, 2010, p.53

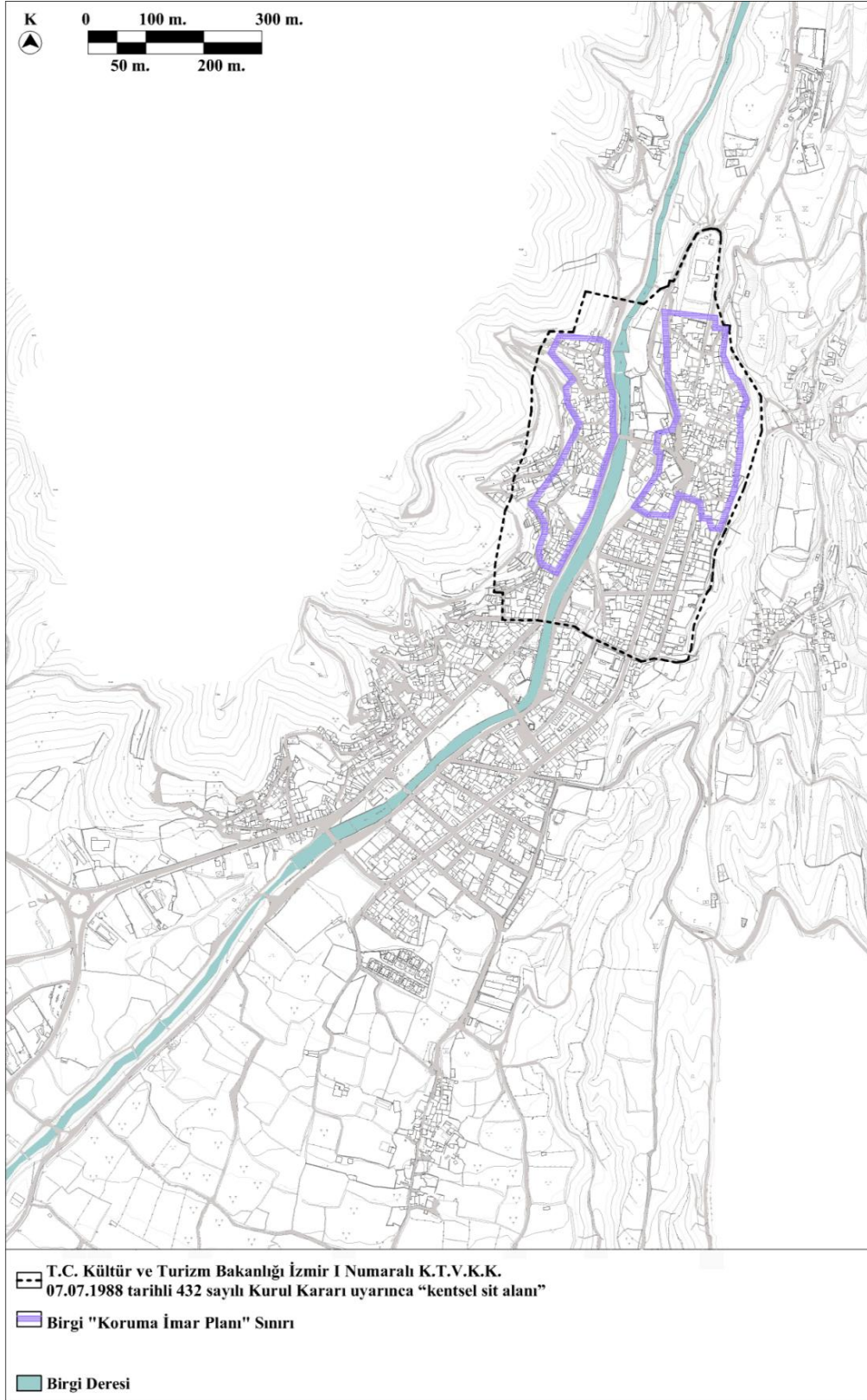


Figure 74, Borders of Birgi Master Plan⁶⁹

⁶⁹ Ibid.p.54

5.3 EVALUATION OF THE HAMAM

5.3.1 VALUES

Values are going to be inspected under 3 sub-categories, intrinsic values, extrinsic values and contemporary usage values. This evaluation was made according to the principles in Bernard M. Feilden,'s precious work "Management Guidelines for World Cultural Heritage Sites" (1993)⁷⁰.

Intrinsic values; Intrinsic values are age, plan scheme, construction technique and materials, workmanship.

The exact age of the building is not known, but depending on the historical study, hamam is dated to 15th century. All the hamams in Birgi were made in this century. The plan scheme of Çukur Hamam is a unique example in Birgi and also in close surrounding. At Sıcaklık section one of the *halvets* can be entered through a transition space from another *halvet*.

The construction technique and materials used at Cukur hamam is a continuity of the construction tradition at Birgi.

From the workmanship at the Çukur hamam we had knowledge about the quality and the construction details from the 15th century of Birgi.

Extrinsic values; Extrinsic values are social values, educational values, cultural value, environmental importance value and rarity value in our case.

Bathing in hamam is a traditional social activity and has a place in Turkish daily life and culture both for men and women. This action involves contemporary social interaction in the community and plays a role in establishing social and cultural identity.

⁷⁰ B. M. Feilden, 1993, pp.14-21

Either the current situation or after the restoration phase, the building will give educational information about bathing culture and Ottoman hamams. These resources had potentials for cultural tourism, and the awareness of culture and history that it promotes as a means of integrating historic resources in present-day life.

Cukur hamam is located near a ruin of mill and in front of a madrasa at Okul Street. In addition to that there are traditional residential buildings showing the social and cultural features of daily life of past. Therefore Cukur hamam and its surrounding reflect the life of inhabitants living in Birgi with their social and cultural aspects.

As stated before the plan scheme is a rare example among the other hamams. And also the climbing footsteps at the domes are unique examples.

Contemporary usage value; use values are related to today's functional value, market value.

Market value comes from the value of the land that the building was build on the building itself and the contribution that hamam provides for Birgi's touristic advertisement.

Functional value is the related to its market value, as it involves the continuity of the original type of function or the possibility of maintaining a new function.

5.3.2 POTENTIALS

Çukur Hamam as being in the vicinity of Birgi Town centre constitutes a unity with Dervis Aga Madrasa and neighbouring traditional residential buildings. Since some sections of hamam are demolished it demonstrates the building technology. Çukur Hamam includes various spaces of different qualities and the authenticity of the building is still continues.(please refer to Space Analyses).

5.3.3 PROBLEMS

On behalf of the conservation consciousness, what Birgi needs is a tourism plan for the town. There are not many hotels for the tourists to stay in town. This makes the town only one day visit for the tourists.

The building is in bad condition. Beside the material problems, the building has severe structural problems. The lack of drainage system caused dampness problems both at roof and at the foundation.

The spaces of the building are small and not illuminated sufficiently. This issue limits the function possibilities.

5.4 GENERAL RESTORATION APPROACH

The main purpose of the restoration project is ceasing primarily the structural then the material deformations and later by assigning new functions sustaining its usage. In addition to that a management model for its maintenance will be developed.

In the course of this study, the significance of Çukur Hamam for Birgi's history and with the new functions its possible contributions to its neighbourhood and the city will be analyzed. In the restitution work, the building periods and the effects of interventions in those periods will be researched.

In this respect, the principles of intervention to the edifice are taken in three categories. These are;

The decisions on the conservation of the building,

The decisions on the restitution periods,

The decisions on the new function.

5.4.1 PRINCIPLES RELATED TO CONSERVATION

These principles are designed to conduct the conservational interventions to the structural problems, material decays and architectural elements. In order to give decisions on these problems, detailed material analyses should be made.

In the areas determined by the restoration project archaeological excavations in the supervision of Ödemiş Museum will be planned.

- The survival of the building and solving its problems with minimum interventions will be maintained.
- The priority will be given to solve the urgent problems. Other problems will be solved in a schedule including the research and analysis stages.
- The unqualified buildings damaging Çukur Hamam will be removed.
- The structurally deficient parts will be reinforced by using the original material and the building technique.
- All the authentic materials and architectural elements and their traces will be kept as it is and be conserved only if it is necessary.

5.4.2 PRINCIPLES RELATED TO RESTITUTION PERIODS

- The first and the second period of the building when it was used as hamam will be conserved; the third period when it lost its function and the additions of this period will be removed.
- In the *külhan* and *soğukluk* parts of the building which consist restitution problems archaeological excavations supervised by Odemiş Museum will be planned.
- Regardless of its reliability any architectural elements belonging to the periods will be completed.
- The traces which were failed to be interpreted in the course of restitution work will be conserved as it is, for evaluating in future studies.

5.4.3 PRINCIPALS RELATED TO NEW FUNCTION

- The function to be assigned to the building will be decided according to the environment, capability and existing qualities of the building.

- All the interventions that are necessary for the new function are made up with new materials and building techniques.
- In the context of the new function the interventions will be made up with recyclable materials and details and paid attention to work with the original configuration.
- For the survival of the building, the new function will be handled with minimum intervention and minimum load.

5.5 INTERVENTION DECISIONS

5.5.1 DECISIONS RELATED TO CONSERVATION

Rising Damp and Rain Water Penetration - Rising damp causes loss of mortar and detachment which result with structural problems on the south facade and the walls connected to it. To solve this problem a drainage system which its size and details are determined in the restoration project will be installed.

Rain water penetration - After removing the vegetal formations on the roof, the traces of the original drainage system will be detected and the necessary parts will be restored by capping method (using original material and technique-stone and horasan plaster according to the results of material analyses). Open spaces will be rain proofed by building protection roof.

Area loss – The area losses endangering the structural configuration of building will be integrated with the original material and building technique. The plaster will be analyzed in the walls with joint losses and then according to the results of these analyses pointing will be made.

Cracks and fissures – The cracks will be reinforced by injecting original plaster. Fissures will be left as they were.

Detachment – To prevent the the advance of detachments on the walls, the borders of the present plaster will be cleaned with distilled water and reinforced with the same plaster. On the surfaces with blind detachment suitable plaster with kemical compound will be injected in according to the material analyses.

Discoloration - On the parts where discoloration takes place due to the efflorescence the surfaces will be mechanically cleaned by brush after softening by vaporizing.

Rust – The rust stains on walls will be cleaned by cushioning paper dust after moisturizing with 20% Phosphoric Acid diluted in distilled water.

Deposits – The earth deposit covering the floor of inner spaces will be removed. In case of finding the entire original floor covering, necessary controls will be made by specialists to reveal its static condition. If the original floor covering is found out partially then this part will be reinforced, other parts will be kept they were.

Biological growth – The grass and trees will be withered progressively by injecting 20% hydrogen peroxide in distilled water. The areas where moss formations are observed will be cleaned by brushing with distilled water and then 20% Hydrogen peroxide will be injected.

5.5.2 DECISIONS RELATED TO RESTITUTION

Archaeological Excavations - On the areas demonstrated in plates, archaeological excavations will be held under the supervision of Odemiş Museum and to reach the foundation level. The ground level rising around the building will be rased down to its original level. The possible artefacts, traces and details will be conserved according to the decisions that are determined by the relevant principles.

Removals - The first and second historical periods of the building will be revealed out. The additions made in the third period and later will be removed. These few additions are foundation traces of a house on *soğukluk* section, the iron door case at the junction of Z05 and Z02 and the brick wall closing the heart of *külhan*.

Additions - As mentioned in the restoration decisions of the building the architectural elements of later periods will not be completed regardless of their reliability. For this reason no addition according to the restitution will be made.

Unidentified Traces - The traces which cannot be interpreted in restitution study will be conserved in its present situation.

5.6 NEW FUNCTION

5.6.1 DECISIONS RELATED TO NEW FUNCTION

The building is very demolished in its present condition. This situation produces a lot of evidence for the building technique, material usage, heating system, water distribution and disposal system.

The traditional hamam culture has lost in Birgi due to the lack of active hamam buildings. To sustain this culture and conduct it to the next generations, the building will be converted to the hamam culture museum.

With this function given to the building, it is aimed to illustrate the bathing culture without losing this information. In this respect, avoiding the permanent additions, the authentic value of Çukur Hamam will be presented audio-visually with the aid of simple and removable additions.

5.6.2 EVALUATION OF THE SPACES

The evaluation of spaces has been carried out related to their circulation layouts, areas of spaces, quality of light in order to understand their physical and architectural capacities as well as requirements.

5.6.2.1 CIRCULATION LAYOUT AND QUALITY OF LIGHT

According to circulation layout, the spaces in Çukur Hamam can be classified as:

- The spaces that can be reached directly from the street.(1st)
- The spaces that can be reached passing through another space.(2nd)
- The spaces that can be reached passing through two spaces.(3rd)
- The spaces that can be reached passing through three spaces.(4th)



Figure 75. Evaluation of the spaces in terms of circulation layout

The spaces are categorized in five groups in terms of the quality of daylight. The illumination level is listed from the most lighted space towards the darkest one. At the evaluation, door openings are also counted as daylight source.

There are more oculi on the domes than on the vaults. This requires the domes to be taken as more illuminated spaces.

The spaces where the domes are demolished were estimated as the most illuminated spaces.

The spaces attached to the spaces with demolished domes were taken as the secondary most illuminated spaces.

The spaces which surrounding roofs are intact and the daylight is penetrating from the oculi and door openings are considered as the tertiary most illuminated spaces.

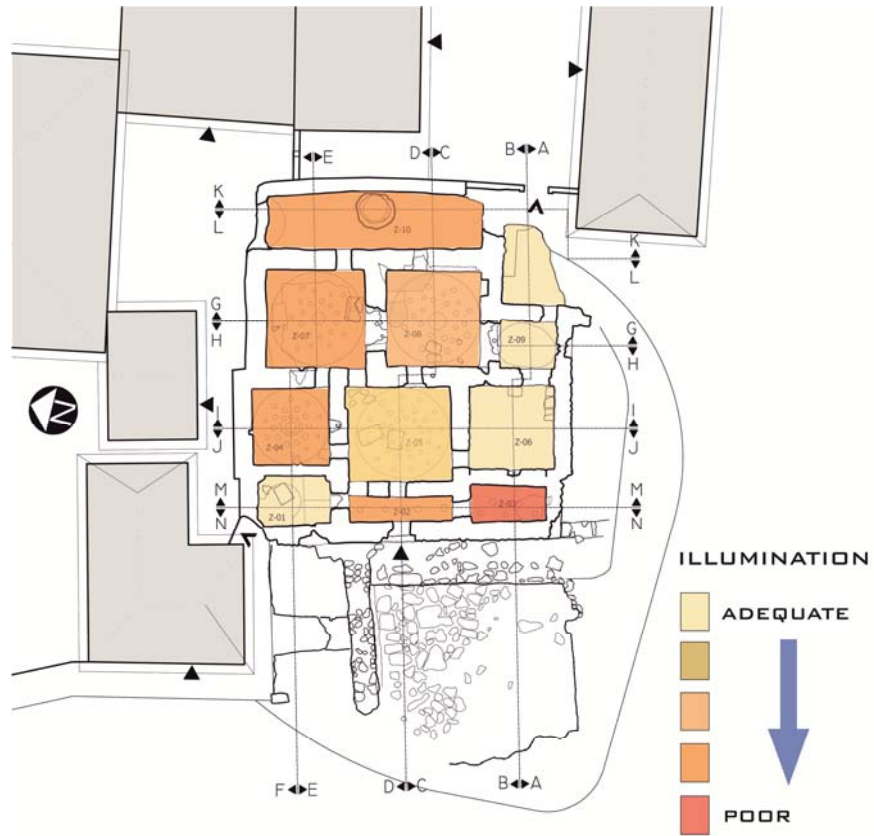


Figure 76. Evaluation of spaces in terms of illumination

5.6.2.2 AREAS OF SPACES

Before assigning new functions to the relevant spaces the areas of those spaces were examined to check their capability of tolerating these new functions. Çukur Hamam generally consists of small spaces among which the largest space is below 20m².

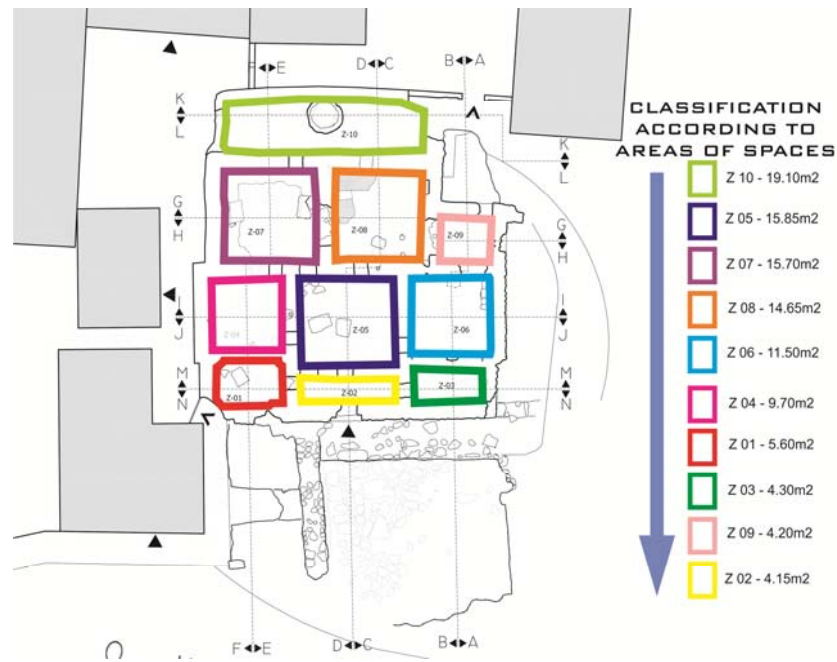


Figure 77. Evaluation of spaces in terms of areas

5.6.3 INSTALLATIONS

For making visual animation the spaces of Z01, Z03 and Z04 will be halved; other spaces will be crossed diagonally with glass brick blocks attached to the building walls with stainless steel structures. On these blocks 3D transparent pictures will be adhered. With the stereoscopic 3D glasses distributed at the main entrance, the architectural elements such as *kurna*, *seki* which only their traces left will be completed virtually and bathing occasion will be depicted.

The bathing occasion which is aimed to be represented visually will be supported aurally from the openings in dome and with speakers mounted on the protective roof.

The Roof - The spaces Z01, Z06, Z09, and Z11 where the roof is demolished will be covered with a protection roof projected in modern materials and techniques to isolate from outer conditions.

The oculi on domes and vaults will be conserved with the elements determined in the restoration project.

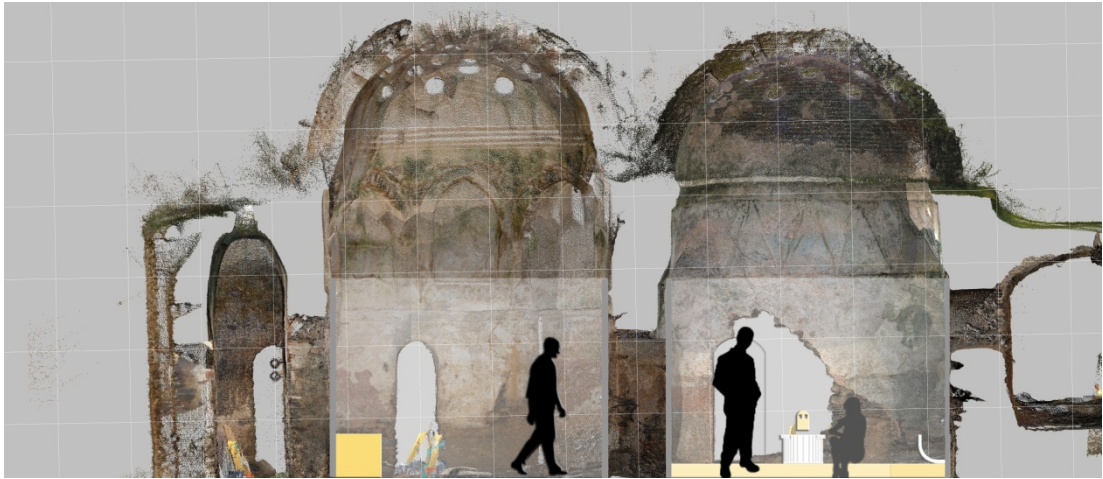


Figure 78; New Function; Section DD

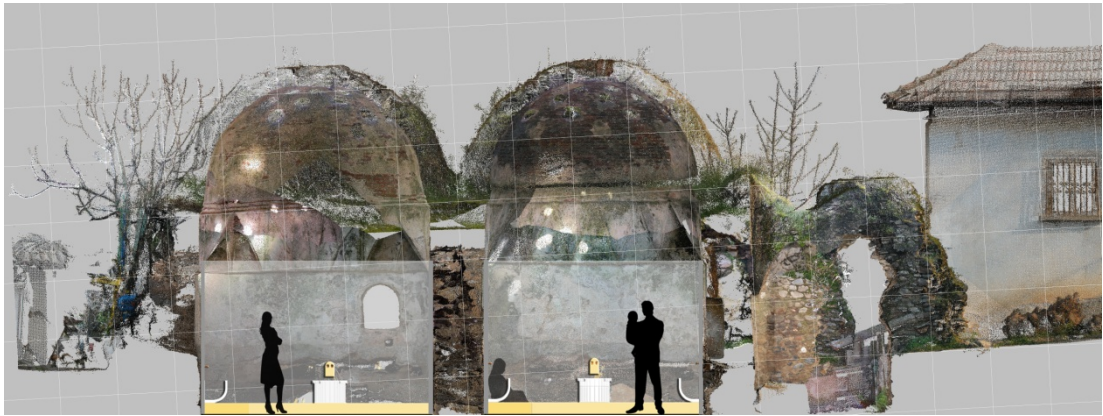


Figure 79; New Function, Section GG

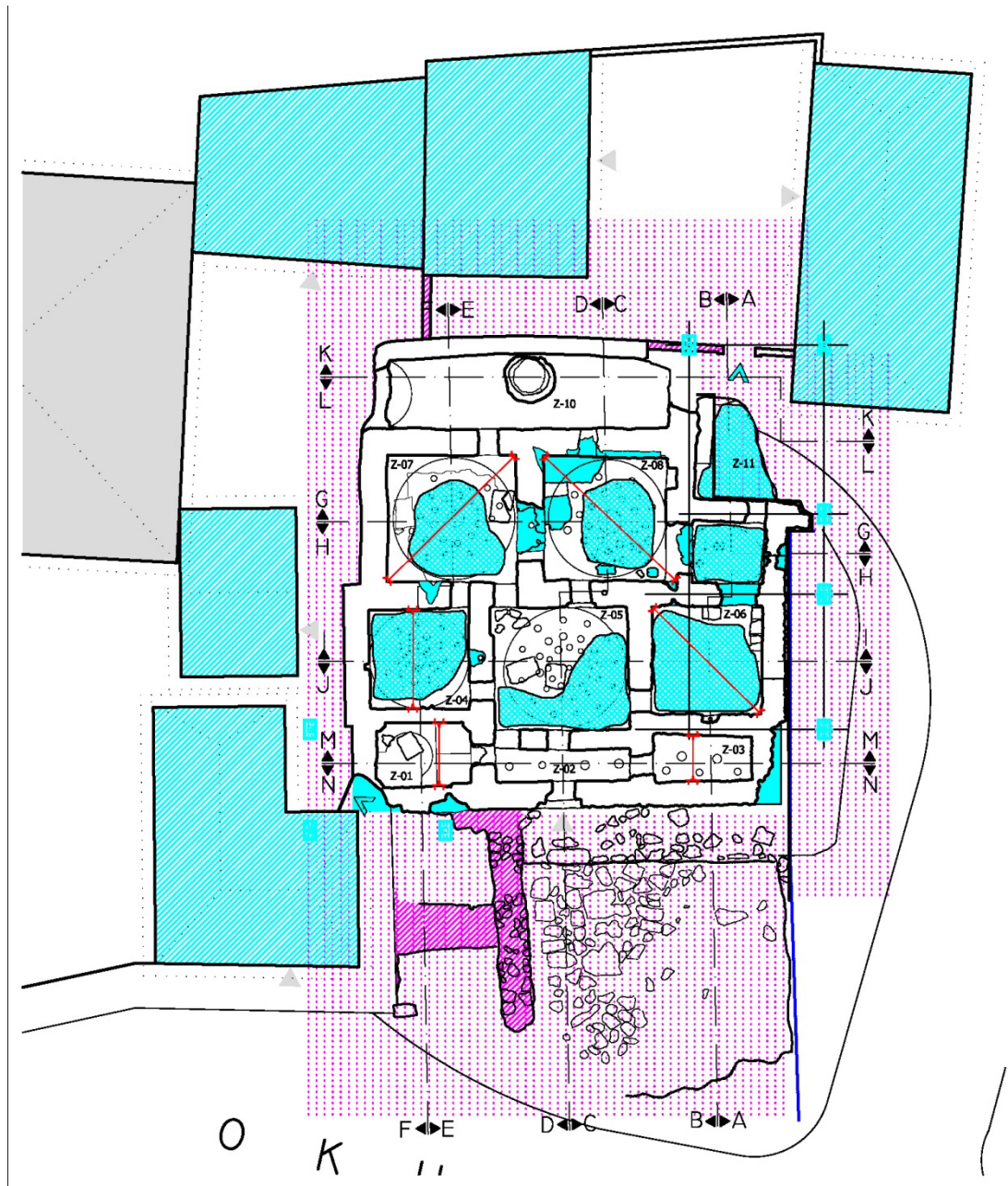


Figure 80, Restoration Project, Floor Plan



Figure 81, Restoration Project, Roof Plan

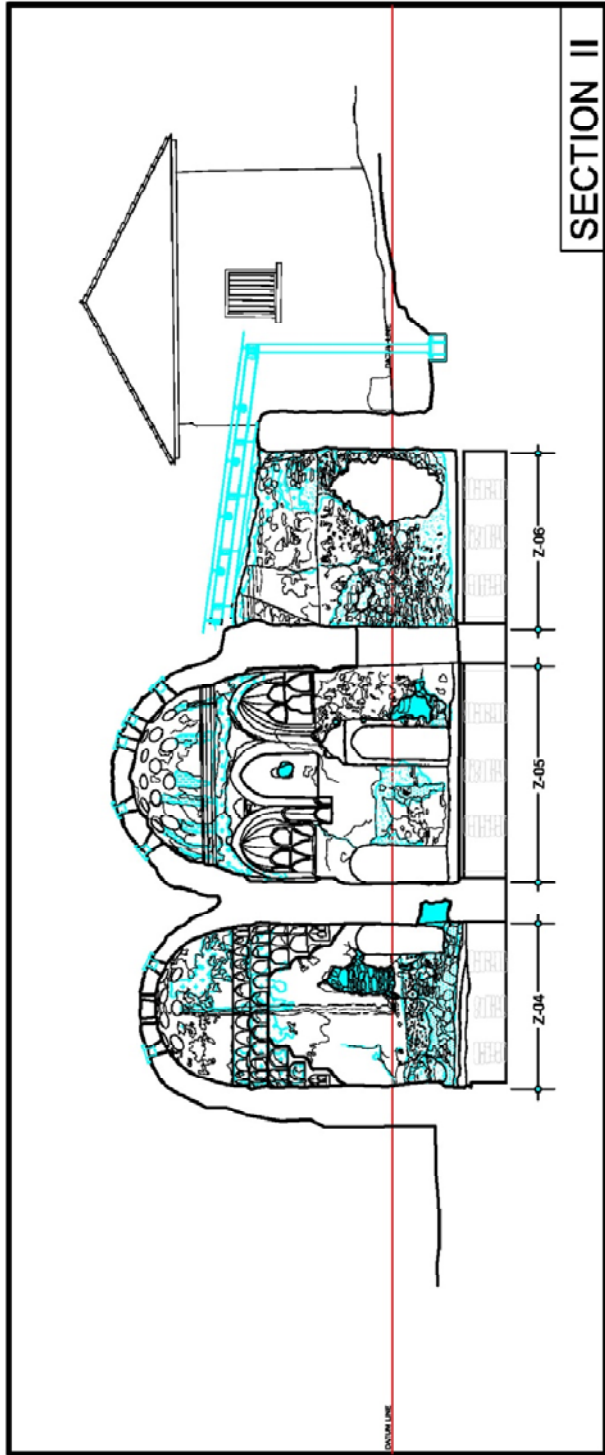


Figure 82, Restoration Project, Section II

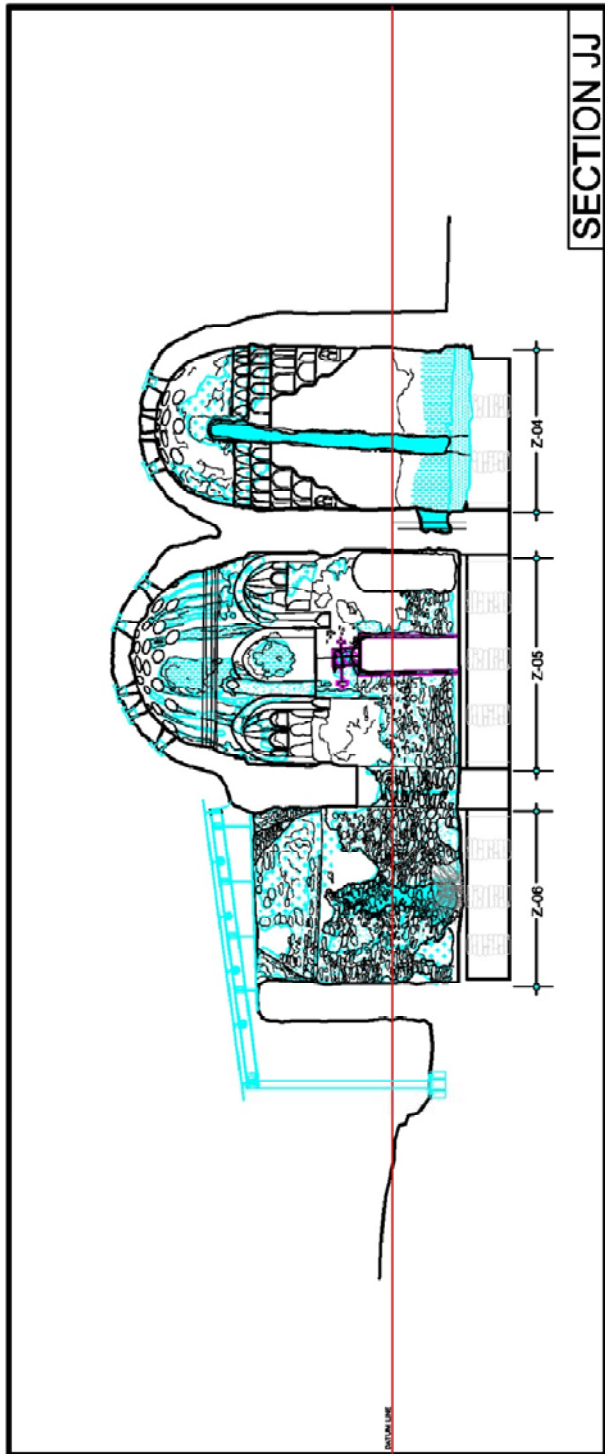


Figure 83, Restoration Project, Section JJ

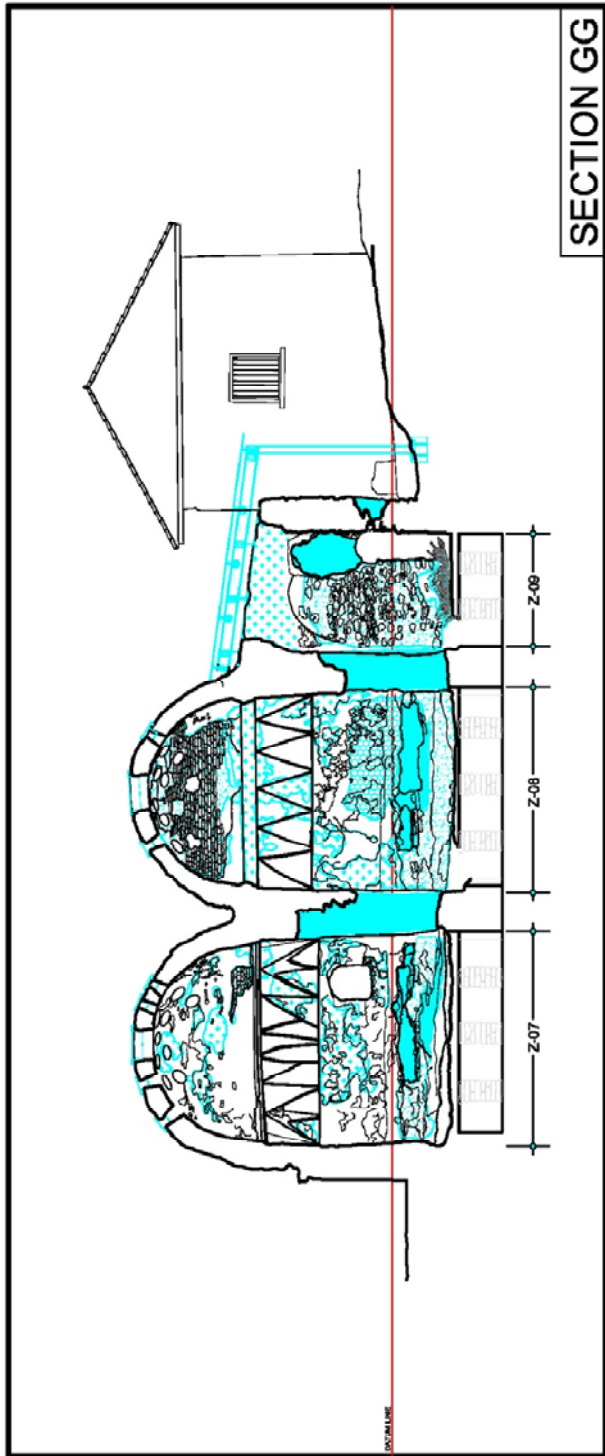


Figure 84, Restoration Project, Section GG

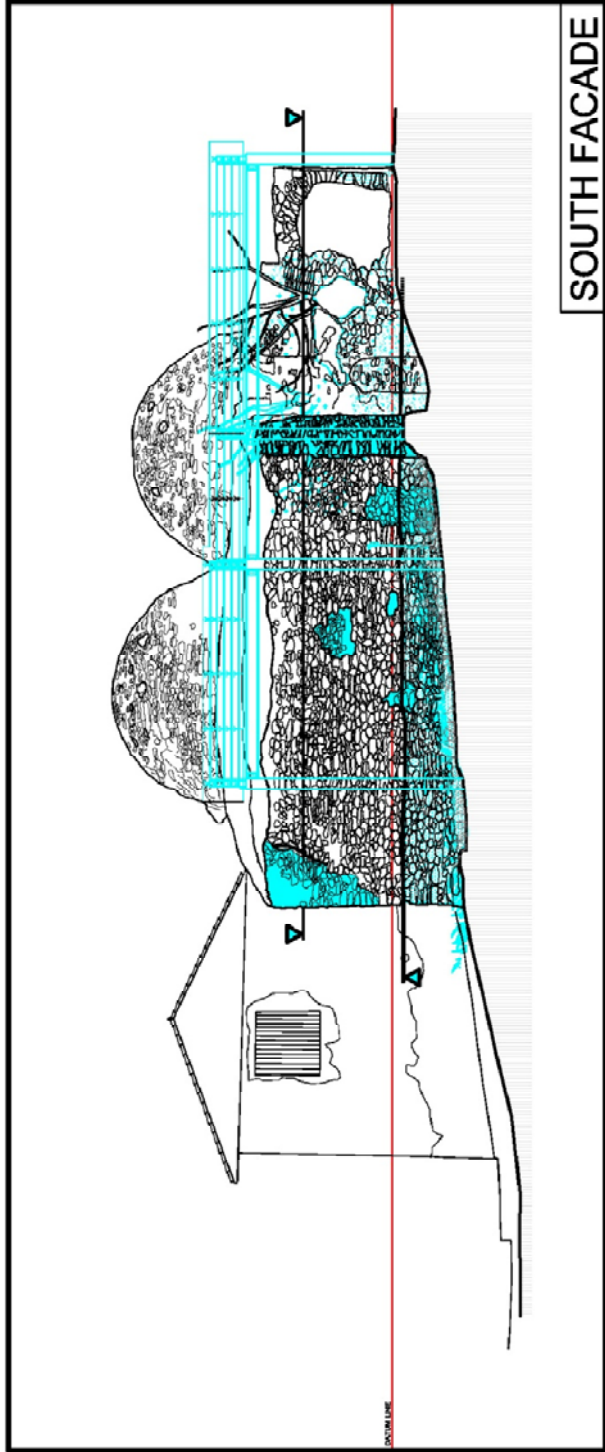


Figure 85, Restoration Project, South Facade

REFERENCES

BOOKS

1. Behiç Galip Yavuz, *Birgi Coğrafyası, Tarihçesi, Tarihi Yerleri*, (Ödemiş, 1990)
2. Charles Texier, *Küçük Asya: Coğrafyası, Tarihi ve Arkeolojisi*, (İstanbul: Enformasyon ve Dokümantasyon Hizmetleri Vakfı, 2002)
3. Ekrem Hakkı Ayverdi, *Osmanlı Mimarisi 'nde Çelebi ve II. Sultan Murad Devri*, (İstanbul: İstanbul Fetih Cemiyeti, 1989)
4. Ekrem Hakkı Ayverdi, *Osmanlı Mimarisi 'nde Fatih Devri*, (İstanbul: İstanbul Fetih Cemiyeti, 1989)
5. Elif Şehitoğlu, *Bursa Hamamları*, (Yurt Yayınları 2008) 50,52, 67
6. Fikret Yegül, *Antik Çağ'da Yıkanma ve Hamamlar*, (İstanbul: Homer, 2006)
7. İbn Batuta, *İbn Batuta Seyahatnamesi'nden Seçmeler*, ed. İsmet Parmaksızoğlu (Ankara: MEB, 1971)
8. Nezih Başgelen, *Birgi Hakkında Unutulan Bir Rapor*, (İstanbul: Arkeoloji ve Sanat, 2008)
9. Nezih Başgelen, *Birgi'den Gevaş'a*, (İstanbul: Arkeoloji ve Sanat, 1987)
10. Osman. Turan, *Selçuklular Zamanında Türkiye*, (İstanbul: Ötüken, 1971)
11. Osman. Turan, *Türk Cihan Hakimiyeti Mefkuresi Tarihi*, (İstanbul: Ötüken, 2003)
12. Tülay Taşçıoğlu, *Türk Hamamı*, (İstanbul: TTOK Yayınları, 1998)
13. Yılmaz Önge, *Anadolu'da XII-XIII. Yüzyıl Türk Hamamları*, (Ankara, VGM Yayınları, 1995)
14. Yılmaz Önge, *Mimarbaşı Koca Sinan Yaşadığı Çağ Ve Eserleri* (İstanbul, 1988)

REFERENCE WORKS

1. Besim Darkot, "Birgi" in *İslam Ansiklopedisi*, Vol.2 (Ankara: Maarif Matbaası, 1944)
2. Büyük Larousse Sözlük ve Ansiklopedisi, (İstanbul: Gelişim Yayınları, 1986)
3. H. Abbasoğlu, "Hamam" in *Eczacıbaşı Sanat Ansiklopedisi*, Vol.2 (İstanbul: YEM Yayınları, 1998)

4. Semavi Eyice, “Hamam” in *Türk Diyanet Vakfı İslam Ansiklopedisi*, V.15 (Ankara: Diyanet Vakfı Yayınevi, 1961)
5. ICOMOS International Charter for the Conservation and Restoration of Monuments and Sites, Venice Charter. (1964)
6. ICOMOS ICOMOS Charter, Principles for the Analysis, Conservation and Structural Restoration of Architectural Heritage. (2003)

THESIS-DISSERTATIONS

1. Filiz Diri, Construction Techniques of Traditional Birgi Houses, Unpublished Master Thesis, (Ankara: ODTU, 2010)
2. Gülşen Dişli, An Investigation on the Water Supply and Drainage Systems of Historical Turkish Baths, Unpublished Master's Thesis, (Ankara; ODTU, 2008)
3. Kemal Ahmet Aru, *Türk Hamamları Etüdü*, (İstanbul: İstanbul Teknik Üniversitesi, 1949)
4. Mine Hamamcıoğlu, Restoration Project of Dervişağa Medrese in Birgi, Ödemiş, İzmir, Turkey, (Ankara; ODTU, 1994)
5. Necla Uslucan, *Restoration Project Of Beylerbeyi Hamamı In Edirne* (Ankara: ODTU, 1992)
6. Seda Kula Say, *Erken Dönem Osmanlı Hamamlarında Eğrisel Örtüye Geçiş Sistemleri*, (İstanbul: İstanbul Teknik Üniversitesi, 2007)
7. Şeyda Güvenç, *Antalya Kaleiçi'nde Yenikapı, Gavur Hamamı Restorasyon Projesi*, Yüksek Lisans Tezi, (İstanbul: İTÜ, 1997)
8. Süheyla ATLI, , *Mimar Sinan Dönemi Hamamları Konusunda Bir Araştırma*, Unpublished Master Thesis (İstanbul: MSÜ, 1990)

JOURNALS

1. “Bizans Hamamları” in Türkiye Turing ve Otomobil Kurumu Belleteni, 110/1951
2. Semavi Eyice, “İznik’te Büyük Hamam ve Osmanlı Devri Hamamları Hakkında Bir Deneme” in *Tarih* Vol.11/15 (İstanbul: İstanbul Üniversitesi 1960)
3. Yılmaz Önge, “Külliyelerimizin Yıkılan Hamamları” in *Önasya*, Vol.7, S. 74, (Ankara, 1971)

4. Matero F. G. Loss, Compensation, and Authenticity: The Contribution of Cesare Brandi to Architectural Conservation in America, pp. 44-57. (2007)
5. Samir F. and Benzagouta D.S., The Reuse of Hammam Suq Al Ghezal; Towards a Sustainable Future, Conference On Technology & Sustainability in the Built Environment, pp. 201-216. (2007)

OTTOMAN SOURCES

1. "Aydın Eyaleti Salnamesi" of 1303
2. "Temettüat Defterleri" of 1844
3. "Timar Defteri" of 1451
4. "Defter-i Hakani" (register no. 166) of 1530

APPENDIX A

COMPARATIVE STUDY CHARTS




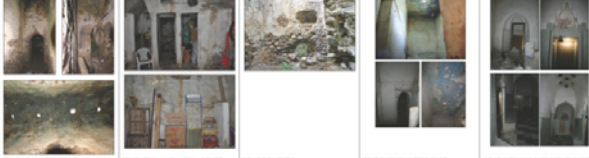



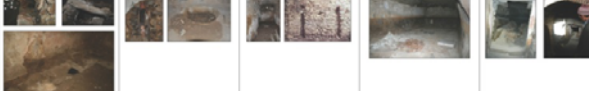

	CUNUR HANCIKAR - SINIG	CARG HANCIKAR - SINIG	BANGAL HANCIKAR - SINIG	TUGAYAN HANCIKAR - SINIG	SINIG HANCIKAR - SINIG
<p>COMPARATIVE STUDY</p> <p>PLAN LAYOUT</p> 					
<p>EXTERIOR</p> 					
<p>INTERIOR</p> 					
<p>ROOF</p> 					
<p>WALLS</p> 					
<p>CEILING</p> 					
<p>INTERIOR FINISHING</p> 					
<p>ARCHITECTURAL ELEMENTS</p> 					
<p>INTERIOR SPACES</p> 					
<p>GENERAL INFORMATION</p>					

Figure 86 Comparative Study Chart 1

	MİLLİ MUSEUM - THE	ŞEHİRCİ MUSEUM - THE	ŞEHİRCİ MUSEUM - THE	YERİNDİRİ MUSEUM - THE	ŞİTİ MUSEUM - THE
PLAN LAYOUT					
EXTERIOR					
INTERIOR					
ROOF					
MOSAIC					
EXTERIOR WALLS					
ARCHITECTURAL ELEMENTS					
INTERIOR WALLS					
EXTERIOR INFRASTRUCTURE					

Figure 87 Comparative Study Chart 2

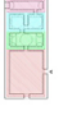

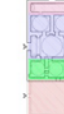

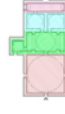

















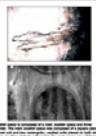




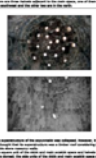
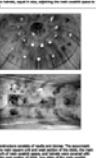
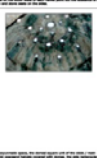















<p>Q</p> <p>ANALYSIS</p> <p>COMPARATIVE STUDY</p> <p>PLAN</p> <p>SECTION</p> <p>DETAIL</p> <p>PHOTO</p> <p>TEXT</p>	<p>BİÇAK KALESI HANIR</p>  <p>The building is a rectangular structure with a central courtyard. It features a main entrance on the left side and a smaller entrance on the right. The walls are made of brick and the roof is flat.</p>	<p>YERLİK KALESI HANIR</p>  <p>The building is a rectangular structure with a central courtyard. It features a main entrance on the left side and a smaller entrance on the right. The walls are made of brick and the roof is flat.</p>	<p>KARALI HANIR/TAZI/ŞEY - UZLA</p>  <p>The building is a rectangular structure with a central courtyard. It features a main entrance on the left side and a smaller entrance on the right. The walls are made of brick and the roof is flat.</p>	<p>ŞYK HANIR - ŞEYRİGAR</p>  <p>The building is a rectangular structure with a central courtyard. It features a main entrance on the left side and a smaller entrance on the right. The walls are made of brick and the roof is flat.</p>	<p>HİREKE HANIR - DÜCE</p>  <p>The building is a rectangular structure with a central courtyard. It features a main entrance on the left side and a smaller entrance on the right. The walls are made of brick and the roof is flat.</p>
<p>PLANIMETRE</p> 	<p>PLANIMETRE</p> 	<p>PLANIMETRE</p> 	<p>PLANIMETRE</p> 	<p>PLANIMETRE</p> 	
<p>ELAVATÖR</p> 	<p>ELAVATÖR</p> 	<p>ELAVATÖR</p> 	<p>ELAVATÖR</p> 	<p>ELAVATÖR</p> 	
<p>İÇGÖRÜŞÜ</p> 	<p>İÇGÖRÜŞÜ</p> 	<p>İÇGÖRÜŞÜ</p> 	<p>İÇGÖRÜŞÜ</p> 	<p>İÇGÖRÜŞÜ</p> 	
<p>İÇGÖRÜŞÜ</p> 	<p>İÇGÖRÜŞÜ</p> 	<p>İÇGÖRÜŞÜ</p> 	<p>İÇGÖRÜŞÜ</p> 	<p>İÇGÖRÜŞÜ</p> 	
<p>İÇGÖRÜŞÜ</p> 	<p>İÇGÖRÜŞÜ</p> 	<p>İÇGÖRÜŞÜ</p> 	<p>İÇGÖRÜŞÜ</p> 	<p>İÇGÖRÜŞÜ</p> 	
<p>İÇGÖRÜŞÜ</p> 	<p>İÇGÖRÜŞÜ</p> 	<p>İÇGÖRÜŞÜ</p> 	<p>İÇGÖRÜŞÜ</p> 	<p>İÇGÖRÜŞÜ</p> 	
<p>İÇGÖRÜŞÜ</p> 	<p>İÇGÖRÜŞÜ</p> 	<p>İÇGÖRÜŞÜ</p> 	<p>İÇGÖRÜŞÜ</p> 	<p>İÇGÖRÜŞÜ</p> 	
<p>İÇGÖRÜŞÜ</p> 	<p>İÇGÖRÜŞÜ</p> 	<p>İÇGÖRÜŞÜ</p> 	<p>İÇGÖRÜŞÜ</p> 	<p>İÇGÖRÜŞÜ</p> 	

Figure 88 Comparative Study Chart 3

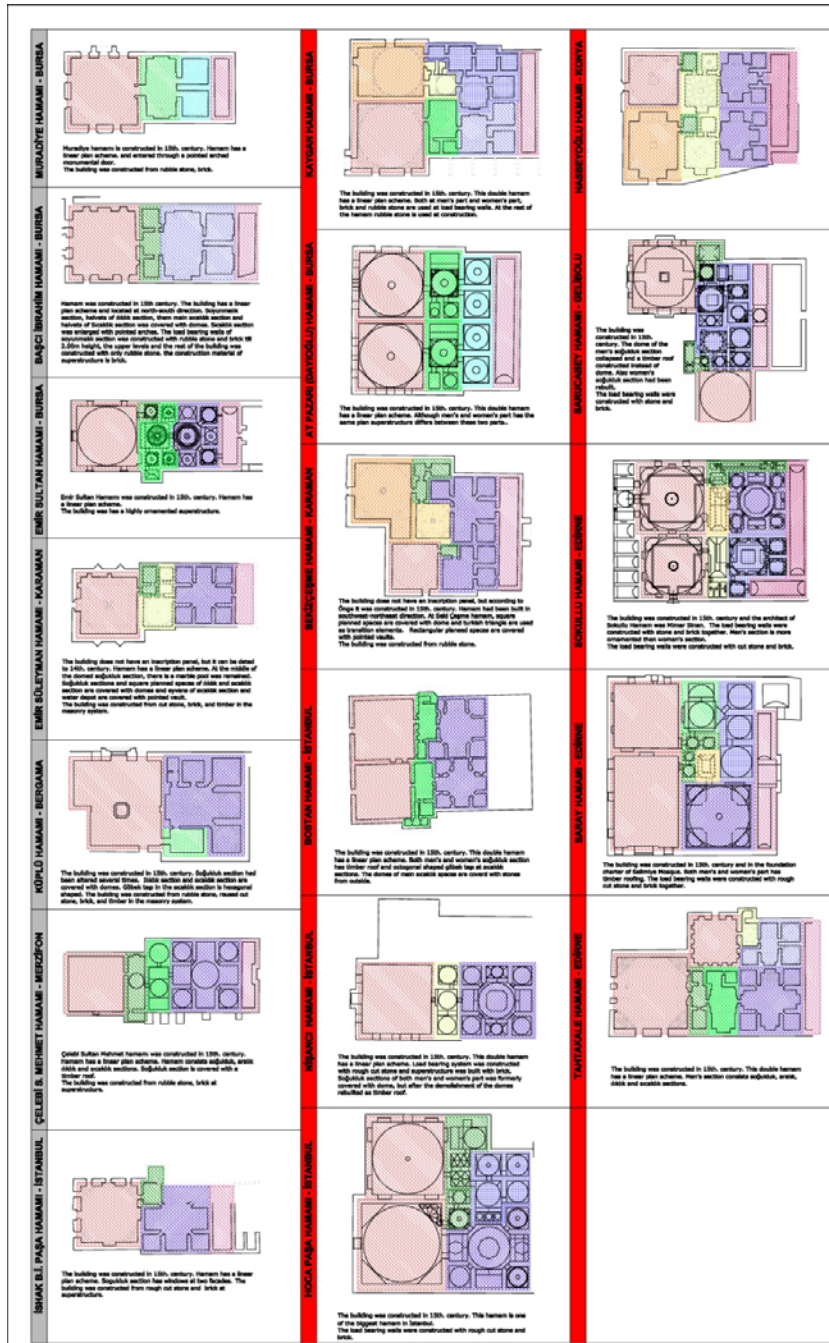


Figure 89 Comparative Study Chart 4