

EXTERNAL CONFIGURATION DESIGN AND AERODYNAMIC  
OPTIMIZATION OF MODULAR GUIDED MUNITIONS

A THESIS SUBMITTED TO  
THE GRADUATE SCHOOL OF NATURAL AND APPLIED SCIENCES  
OF  
MIDDLE EAST TECHNICAL UNIVERSITY

BY

MERT GÜN

IN PARTIAL FULFILLMENT OF THE REQUIREMENTS  
FOR  
THE DEGREE OF MASTER OF SCIENCE  
IN  
AEROSPACE ENGINEERING

SEPTEMBER 2019



Approval of the thesis:

**EXTERNAL CONFIGURATION DESIGN AND AERODYNAMIC  
OPTIMIZATION OF MODULAR GUIDED MUNITIONS**

submitted by **MERT GÜN** in partial fulfillment of the requirements for the degree of  
**Master of Science in Aerospace Engineering** Department, **Middle East Technical  
University** by,

Prof. Dr. Halil Kalıpçılar  
Dean, Graduate School of **Natural and Applied Sciences** \_\_\_\_\_

Prof. Dr. İsmail Hakkı Tuncer  
Head of Department, **Aerospace Engineering** \_\_\_\_\_

Assoc. Prof. Dr. Nilay Sezer Uzol  
Supervisor, **Aerospace Engineering, METU** \_\_\_\_\_

**Examining Committee Members:**

Prof. Dr. Ozan Tekinalp  
Aerospace Engineering, METU \_\_\_\_\_

Assoc. Prof. Dr. Nilay Sezer Uzol  
Aerospace Engineering, METU \_\_\_\_\_

Assist. Prof. Dr. Munir Elfarra  
Aerospace Sciences Faculty, Ankara Yıldırım Beyazıt University \_\_\_\_\_

Assist. Prof. Dr. Ali Türker Kutay  
Aerospace Engineering, METU \_\_\_\_\_

Assist. Prof. Dr. Mustafa Perçin  
Aerospace Engineering, METU \_\_\_\_\_

Date: 12.09.2019

**I hereby declare that all information in this document has been obtained and presented in accordance with academic rules and ethical conduct. I also declare that, as required by these rules and conduct, I have fully cited and referenced all material and results that are not original to this work.**

Name, Surname: Mert GÜN

Signature:

## **ABSTRACT**

### **EXTERNAL CONFIGURATION DESIGN AND AERODYNAMIC OPTIMIZATION OF MODULAR GUIDED MUNITIONS**

GÜN, Mert

Master of Science, Aerospace Engineering  
Supervisor: Assoc. Prof. Dr. Nilay Sezer Uzol

September 2019, 88 pages

Guided munitions, also known as gliding missiles, are not stand alone systems; rather, they are converted from a dummy body with the help of guidance kits. Guided munitions are used in great number during military operations, unlike air-to-air or cruise missiles. Guided munitions can be classified in two main sub-categories. First group provides guidance and stability with use of strakes. These type of missiles used for relatively short ranges. Second group has wings instead of strakes and effective in larger ranges. Missiles in first subcategory may be converted to second group by changing their strakes with wings. For such a modification, both versions of that missile should be optimized together during the conceptual design phase. The main focus of this study is to obtain a conceptual design tool, by employing Genetic Algorithm with aerodynamic analysis, that optimizes a guided munition geometry which can be used as both versions, with strakes or wings, in terms of aerodynamics related objectives.

Keywords: Aerodynamic Optimization, Missile Outer Geometry, Genetic Algorithm, Guided Munitions, Modular Design

## ÖZ

### MODÜLER GÜDÜMLÜ MÜHİMMATLARIN DIŞ GEOMETRİ DİZAYNI VE AERODİNAMİK ENİYİLEMESİ

GÜN, Mert  
Yüksek Lisans, Havacılık ve Uzay Mühendisliği  
Tez Danışmanı: Doç. Dr. Nilay Sezer Uzol

Eylül 2019, 88 sayfa

Güdümlü mühimmatlar, diğer bir deyişle süzülerek uçan füzeler, tek başlarına kullanılan sistemler değildir; akılsız mühimmatların güdüm kitleri ile birlikte kullanılmasıyla oluşurlar. Güdümlü mühimmatlar, hava-hava ya da seyir füzelerinden farklı olarak, askeri operasyonlarda çok sayıda kullanılırlar. Bu sebeple bu sistemler için maliyet etkinliği güçlendirecek alternatif çözümler ve modüler tasarımlar önem taşımaktadır. Güdümlü mühimmatlar genel olarak iki temel alt başlık altında gruplanabilirler. Birinci grup güdümü ve kararlılığı, kuyruğun yanı sıra ‘gömlek’ adı verilen parçalar ile sağlayan mühimmatlardır. Bu sınıftaki mühimmatlar, görece daha kısa mesafeler için kullanılırlar. İkinci grup ise gömlek yerine kanat kullanarak mühimmatın taşıma-sürüklenme oranını ve buna bağlı olarak mühimmatın menzilini arttırmayı hedefler. İlk gruptaki füzeler gömleklerin kanat ile değiştirilmesi ile ikinci grup mühimmatlara dönüştürülebilirler. Böyle bir modifikasyon için, füzenin kanatlı ve gömlekli versiyonlarının kavramsal tasarım aşamasında birlikte eniyilenmesi gerekmektedir. Bu çalışmanın temel amacı, aerodinamik analizde genetik algoritmayı kullanarak, iki versiyon olarak da kullanılabilen bir füzenin dış geometrisini eniyileyecek bir kavramsal tasarım aracı oluşturmaktır. Bu tasarım aracı dış geometrilerin oluşturulmasını, modellenmesini ve aerodinamik değerlendirilmesini kapsayacaktır.

Anahtar Kelimeler: Aerodinamik Eniyileme, Füzede Dış Geometrisi, Genetik Algoritma, GÜdümlü Mühimmat, Modüler Tasarım

To my Family



## ACKNOWLEDGMENTS

I want to express my deepest gratitude to my supervisor Assoc. Prof. Nilay Sezer-Uzol, whose support, guidance, understanding and patience added considerably to my graduate experience.

I want to thank my parents, my mother Mine Merih Gün and my father Mehmet Gün, together with my grandmother Mualla Temel for their love and understanding without end.

I would like to thank my division chief Ali Karakoç and my group coordinator Serdar Korkem for their technical assistance and critical suggestions. In addition, I want to thank all my colleagues at Guided Munitions Systems Engineering Division, TÜBİTAK SAGE. Also I want to thank TÜBİTAK SAGE for letting me to use the software Missile DATCOM.

My thanks also go to Cansın Sayın not only for promoting me, but also for her valuable assistance and useful recommendations.

## TABLE OF CONTENTS

ABSTRACT .....	v
ÖZ .....	vi
ACKNOWLEDGMENTS .....	ix
TABLE OF CONTENTS .....	x
LIST OF TABLES.....	xiii
LIST OF FIGURES .....	xv
LIST OF ABBREVIATIONS.....	xvii
LIST OF SYMBOLS .....	xviii
CHAPTERS .....	1
1. INTRODUCTION.....	1
1.1. Classification of Missiles .....	1
1.2. Conceptual Design of Missiles .....	5
1.3. Literature Survey.....	6
1.4. Objectives of the Thesis .....	12
1.5. Scope of the Thesis .....	14
2. DESIGN METHODOLOGY .....	15
2.1. Design and Optimization Methodology .....	15
2.2. Optimization Platform.....	18
2.3. Determination of Aerodynamic Coefficients .....	18
2.3.1. Missile DATCOM Validation .....	19
2.3.2. Missile DATCOM Properties.....	21
2.4. Design Parameters and Missile Geometry .....	21

2.4.1. Nose Types .....	25
2.4.2. Roll Orientation .....	29
2.4.3. Wing / Tail Section Considerations .....	30
2.5. Design Objectives.....	31
2.5.1. Lift to Drag Ratio at Trim Condition.....	32
2.5.2. Maximum Usable Lift Coefficient.....	34
2.6. Design Constraints .....	37
2.6.1. Static Stability Constraint .....	37
2.6.2. Control Effectiveness Constraint .....	39
2.6.3. Structural and Integrational Constraints .....	40
2.7. Design of Experiments .....	41
2.8. Optimization Algorithm .....	43
2.8.1. Multi – Objective Genetic Algorithm.....	44
2.8.2. SIMPLEX Algorithm.....	46
3. CASE STUDY .....	49
3.1. Design Parameter Limits .....	50
3.2. Optimization Trials.....	54
4. RESULTS .....	57
4.1. Modular Design Multi-Objective Optimization with MOGA.....	57
4.2. Modular Design Single Objective Optimization with MOGA.....	67
4.3. Fixed Design Multi-Objective Optimization with MOGA .....	69
4.4. Modular Design Multi-Objective Optimization with SIMPLEX Algorithm ..	72
4.5. Comparison of Results with Validated Missile .....	74
5. CONCLUSION AND FUTURE WORK .....	77

REFERENCES .....	81
APPENDICES .....	87
A. OPTIMIZATION WORKFLOW .....	85
B. PROPERTIES of RECENT REVISIONS of MISSILE DATCOM .....	87
C. MISSILE DATCOM INPUT/OUTPUT FILES .....	88

## LIST OF TABLES

### TABLES

Table 1.1. Examples of Missiles based on Launch Platform and Range .....	2
Table 1.2. Advantages and Disadvantages of Missile Control Type [Chin, 1961], [Fleeman, 2001] .....	4
Table 1.3. Literature Survey Summary – Previous Studies before 2009.....	10
Table 1.4. Literature Survey Summary – Recent Studies after 2009.....	11
Table 2.1. Missile External Geometry .....	23
Table 2.2. Surface Planform Geometry Alternatives [Fleeman, 2001].....	30
Table 2.3. Mathematical Expressions of Design Constraints .....	37
Table 3.1. Limits of Body Parameters .....	50
Table 3.2. Limits of Strake Parameters.....	51
Table 3.3. Limits of Wing Parameters .....	52
Table 3.4. Limits of Tail Parameters.....	53
Table 3.5. Optimization Trials .....	54
Table 4.1. DoE and Optimization Algorithms Parameters .....	57
Table 4.2. Numerical Values of Objective Functions of Pareto Optimal Solutions (Trial I).....	63
Table 4.3. Number of Designs Violates the Settled Constraints (Trial I).....	64
Table 4.4. Numerical Values of Objective Functions and Broken Constraints of Some Unfeasible Constraints (Trial I) .....	65
Table 4.5. Comparison of Multi-Objective and Single Objective Optimizations (Trial II and III).....	69
Table 4.6. Numerical Values of Objectives for Single Version Optimization (Trial IV) .....	70
Table 4.7. Aerodynamic Parameters of 2 <sup>nd</sup> Version Missiles in Coupled Optimization (Trial I).....	72

Table 4.8. Numerical Values of Objective Functions of Pareto Optimal Solutions (Genetic Algorithm) and Best Solution of Simplex Algorithm.....	74
Table 4.9. GBU-39 Comparison Results .....	76
Table B.1. Properties of versions of Missile DATCOM .....	87

## LIST OF FIGURES

### FIGURES

Figure 1.1. Classification of Missiles based on Launching Platform and Target Location.....	1
Figure 1.2. Missile Design Iteration [Fleeman, 2001] .....	6
Figure 1.3. 1 <sup>st</sup> Version of the Missile (with strakes).....	13
Figure 1.4. 2 <sup>nd</sup> Version of the Missile (with wings).....	13
Figure 2.1. Design and Optimization Procedure .....	17
Figure 2.2. Longitudinal Aerodynamic Coefficients of Example Model [Atik et al., 2008] .....	20
Figure 2.3. Missile Body External Geometry .....	24
Figure 2.4. Variables of Hexagonal Airfoils [Blake, W. B, et al., 2011].....	24
Figure 2.5. Truncated and Blunted Missile Noses [Blake, W. B, et al., 2011].....	25
Figure 2.6. Dimensional Parameters used in Nose Type Equations [Crowell, 1996].....	26
Figure 2.7. Conical Nose Cone Geometry [Crowell, 1996].....	26
Figure 2.8. Tangent Ogive Nose Cone Geometry [Crowell, 1996] .....	27
Figure 2.9. Power Nosecone Geometries, [Chin, 1961]. .....	28
Figure 2.10. Roll Configuration and Maneuver Control Deflection Alternatives [Fleeman, 2001] .....	29
Figure 2.11. Vector Balance of Forces and Flight Path for Gliding Missiles.....	33
Figure 2.12 . Lift Coefficient vs AoA Curve .....	35
Figure 2.13. Local Pitch Up [Osterhuber, 2011].....	35
Figure 2.14. Usable Lift Coefficients Matrix.....	36
Figure 2.15. $C_m$ vs $\alpha$ Curves.....	38
Figure 2.16. CG and Cp locations for a Statically Stable Missile.....	39
Figure 2.17. Outer Dimension Limits for a Typical Missile.....	41
Figure 2.18. Comparison of Sobol and Random Sequences [Savine, 2019] .....	42

Figure 2.19. Gene, Chromosome and Population in Genetic Algorithm [Zitzler E., 1999] .....	45
Figure 2.20. Crossover Process [Zitzler E., 1999] .....	46
Figure 2.21. Reflected Simplex [Poles, 2003] .....	48
Figure 2.22. Expanded Simplex [Poles, 2003] .....	48
Figure 2.23. Contracted Simplex [Poles, 2003] .....	48
Figure 4.1. Scatter Chart: $C_L/C_D @trim$ vs $C_{L_{max\_usable}}$ .....	59
Figure 4.2. History Graphics of Maximum Usable Lift Coefficient (OBJ 1) (Trial I) .....	60
Figure 4.3. History Graphics of Lift-to-Drag Ratio at Trim Condition (OBJ 2) (Trial I) .....	60
Figure 4.4. Pareto Optimum Solutions (9 Different Optimum Solution) (Trial I) ....	61
Figure 4.5. Geometries of Pareto Optimum Solutions (Trail I) .....	62
Figure 4.6. Percentage of Broken Constraints (Trial I) .....	64
Figure 4.7. Scatter Chart of Unfeasible Designs (Trial I) .....	65
Figure 4.8. Main Effects Chart for OBJ 1 (Trial I) .....	66
Figure 4.9. Main Effects Chart for OBJ 2 (Trial I) .....	67
Figure 4.10. History Graphics of Maximum Usable Lift Coefficient (Trial II) .....	68
Figure 4.11. History Graphics of Lift-to-Drag Ratio at Trim Condition (Trial III) ..	68
Figure 4.12. Percentage of Broken Constraints (Trial IV) .....	70
Figure 4.13. Pareto Optimum Solutions for Single Version Optimization and 2 <sup>nd</sup> Version Values of Coupled Optimization Pareto Optimal Set (Trial IV: black and Trial I: red) .....	71
Figure 4.14. Percentage of Broken Constraints (Trial V) .....	73
Figure 4.15. GBU-39 Missile [Boeing, 2019] .....	75



## **LIST OF ABBREVIATIONS**

### **ABBREVIATIONS**

AoA	Angle of Attack
ATA	Air to Air Missile
ATS	Air to Surface Missile
CFD	Computational Fluid Dynamics
CG	Center of Gravity
DoE	Design of Experiment
GA	Genetic Algorithm
MOGA	Multi Objective Genetic Algorithm
RCS	Radar Cross Section
STA	Surface to Air Missile
STS	Surface to Surface Missile

## LIST OF SYMBOLS

### SYMBOLS

$\alpha$	Angle of Attack
$C_A$	Axial Force Coefficient
$C_D$	Drag Force Coefficient
$C_L$	Lift Force Coefficient
$C_{L_{\max_{usable}}}$	Maximum Usable Lift Coefficient
$C_L/C_D @trim$	Lift-to-Drag Ratio at Trim Condition
$C_{l_\theta}$	Rolling Moment Derivative
$C_N$	Normal Force Coefficient
$C_Y$	Side Force Coefficient
$C_l$	Roll Moment Coefficient
$C_m$	Pitch Moment Coefficient
$C_{m_\alpha}$	Pitching Moment Coefficient with respect to Angle of Attack
$C_{m_\delta}$	Pitching Moment Coefficient with respect to Control Deflection Angle
$C_n$	Yaw Moment Coefficient
$\gamma$	Flight Path Angle
D	Drag Force

$h_{release}$	Release Height
L	Lift Force
L/D	Lift-to-Drag Ratio
R	Range



# CHAPTER 1

## INTRODUCTION

### 1.1. Classification of Missiles

Missiles can be classified according to their several different features. Launching platforms and impact points, trajectory type, type of propulsion system, type of guidance system, control, and trim systems can classify the missiles [Fleeman, 2001; Nielsen, 1967].

Classification based on the launch platform and target location is one of the most accepted types of classification. Four subsections of this categorization are air-to-air (ATA), air-to-surface (ATS), surface-to-surface (STS) and surface-to-air (STA) missiles. Mission profiles of these subsections are shown in Figure 1.1. Some of the missiles, that can be defined as state-of-art are given in Table 1.1 as examples to these categories [Fleeman, 2001]. Missiles within these categories have different objective priorities [Fleeman, 2001]: For air to air missiles maneuverability, range and lightweight are the leading objectives, whereas accuracy, speed, and range are the most important drivers for air to surface missiles; range and lightweight are the most important objectives for surface to surface missiles; weight, altitude and accuracy are the main effects that lead the design for surface to air missiles.

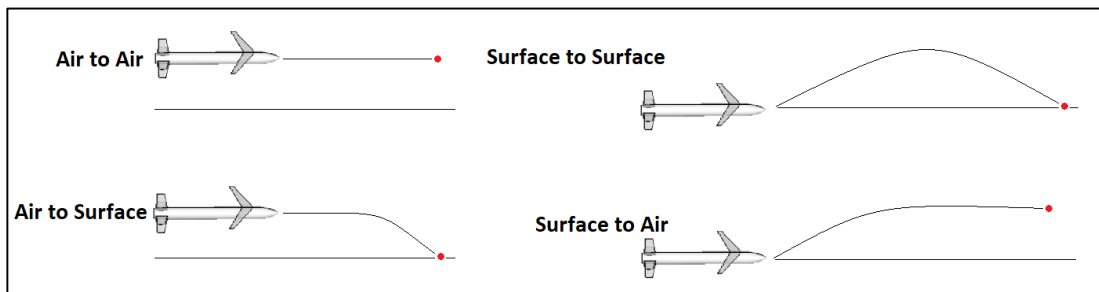
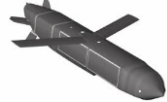

Figure 1.1. Classification of Missiles based on Launching Platform and Target Location

Table 1.1. Examples of Missiles based on Launch Platform and Range

Platform and Target Location	Range	Example	Geometry
Air to Air	Short Range	AA-11	
	Medium Range	AIM-120	
	Long Range	AIM-54	
Air to Surface	Short Range	AGM-65	
	Medium Range	Apache	
	Long Range	AGM-86	
Surface to Surface	Short Range	Javelin	
	Medium Range	MGM-140	
	Long Range	BGM-109	
Surface to Air	Short Range	FIM-92	
	Medium Range	MIM-104	
	Long Range	PAC-3	

Missiles can also be classified based on their trajectory type, which is highly associated with the mission profile of the missile such as ballistic missiles, glide missiles, skip missiles, and cruise missiles. A ballistic missile has a ballistic trajectory. A glide missile, which is also known as guided munition in literature, is launched from an altitude and glides down till it reaches the target. Guided munitions are a specific version of glide missiles. They are not stand-alone systems and converted from dummy bodies with guidance kits. These kits extend the range of the munitions and provide precision with guidance control. Skip missiles, also known as boost-glide trajectory missiles, generate aerodynamic lift in the high upper atmosphere, thus extending the range of pure ballistic range. Missiles powered by air breathing engines are known as cruise missiles. Air-breathing engines produce the necessary almost continuous thrust for a low-level flight. In this thesis, the focus is on optimizing air-to-surface glide missiles.

Further differentiation among missiles can be made on the basis of their propulsion systems. Turbojet, ram-jet or rocket engines can be used by missiles to generate thrust or a missile may not have any propulsion system. If a missile rapidly accelerates to its top speed by short burst of power and then glides to its target, it is called as a boost-glide missile.

Another basis of classification among missiles is the guidance system [Nielsen, 1967]. Control/Command guidance missiles are guided based on the computation of the necessary path for the missile to intercept the target. Radar control or radio control are generally used to link the missile and vantage points. Homing guidance systems control the flight path by employing a seeker. The seekers react to some distinguishing feature of the target. Homing guidance methods may be divided into classes having active, semi-active, and passive guidance systems. In the active homing guidance, the missile contains both a transmitter and a receiver. In semi-active class, the target is illuminated by a tracking radar and the missile receives the reflected signals. Target is the only source of tracking energy in the passive type of guidance.

Type of control is another way to classify missiles [Chin, 1961]. Missiles can be either controlled unconventionally, thrust vector control, or by deflecting their aerodynamic lifting surfaces. Except the unconventional control, missiles can be classified as canard controlled, wing controlled and tail controlled. These different types of control alternatives have some advantages and drawbacks which are given in Table 1.2 [Fleeman, 2001].

Table 1.2. *Advantages and Disadvantages of Missile Control Type [Chin, 1961], [Fleeman, 2001]*

Type of Control	Advantages	Disadvantages
Canard Control	<ul style="list-style-type: none"> <li>• Efficient packaging</li> <li>• Low hinge moments</li> <li>• Increased lift at low <math>\alpha</math></li> <li>• Simplified manufacturing</li> </ul>	<ul style="list-style-type: none"> <li>• High control rates required</li> <li>• Large induced roll especially in high <math>\alpha</math></li> </ul>
Wing Control	<ul style="list-style-type: none"> <li>• Fast response for maneuverability</li> <li>• Small trim <math>\alpha</math></li> </ul>	<ul style="list-style-type: none"> <li>• High hinge moments</li> <li>• Nonlinear aerodynamics</li> <li>• Large wing size</li> <li>• Severe servo power required</li> <li>• Large induced roll</li> <li>• Limited space for large actuators</li> </ul>
Tail Control	<ul style="list-style-type: none"> <li>• Low tail hinge moments</li> <li>• Low induced rolling moment</li> <li>• Low actuator torque</li> </ul>	<ul style="list-style-type: none"> <li>• Decreased lift at low <math>\alpha</math></li> </ul>



## **1.2. Conceptual Design of Missiles**

Before starting the preliminary design of a new product, a conceptual design study is performed to define how a system will work and describe how a new product will meet its performance requirements.

Conceptual design [Chin, 1961] of a missile is carried out with the aim of obtaining the optimal external missile configuration while fulfilling certain performance requirements. This external configuration also defines the baseline geometry for the later phases of the design. In order to establish a balance between various tasks such as aerodynamics, propulsion etc., a great number of design iterations has to be made. Consequently, at the end of this process, various design alternatives can be evolved which all have their different advantages and disadvantages.

The baseline of these major design parameters to be decided depends on the mission definition. The mission profile is established initially with the requirements provided by the military customer and then evaluated considering the potential technology availability. Based on mission requirements, one of the existing missile types and designs is selected as a starting point.

Next step is reflecting new requirements into this baseline design by considering the aerodynamics, propulsion, weight and trajectory in that order since the former's output shall be used as the input in the latter one consecutively. After deciding the external geometry roughly and changing these new requirements, this new conceptual design is evaluated to decide if the necessary performance requirements are met. Following this evaluation, if the missile design fails to fulfill the flight performance or aerodynamic requirements, the missile is resized iteratively. After obtaining a satisfying result at the end of numerous iterations, the missile design is evaluated to see if the design is compatible with the geometric constraints caused by the launching platform since the integration to launching platform fundamentally limits the external geometric properties such as length, weight and span of the missile. In his book

“Tactical Missile Design”, Eugene L. Fleeman [Fleeman, 2001] summarizes the whole process as shown in the Figure 1.2.

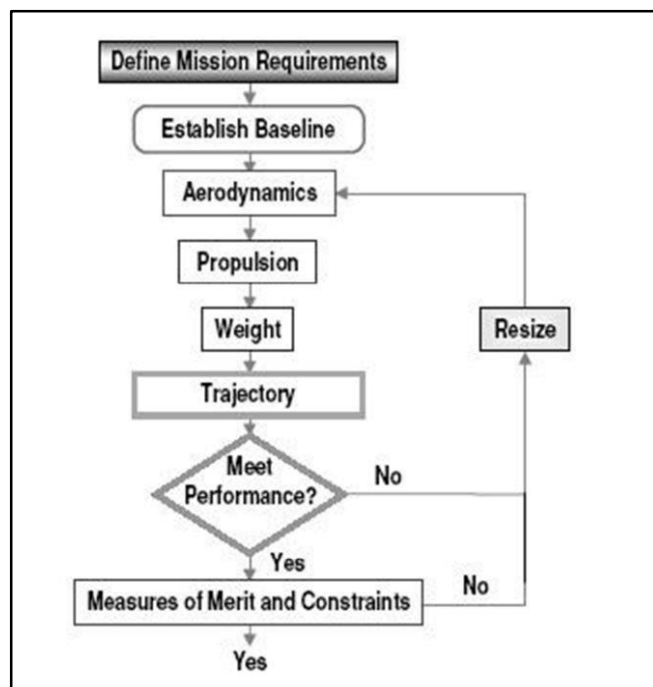

Figure 1.2. Missile Design Iteration [Fleeman, 2001]

### 1.3. Literature Survey

As most of the engineering problems, missile outer configuration design is also a multi-objective optimization problem. In multi-objective optimization, first proposed by Edgeworth [Edgeworth, 1891], a Pareto front set [Pareto *et al.*, 1971], which is a curve comprising the optimum solutions of two objective problems, is obtained in order to evaluate the optimized solutions to a given problem. In order to obtain the Pareto front set with a rapid synthesis, several studies have been conducted in the literature. In order to grasp the previous studies on missile aerodynamic design and optimization and to identify the areas left unattended, a detailed literature survey was carried out.

In 1992, McDonnell Douglas Corporation (MDC) and the NASA Langley Research Center (LaRC) together developed a design tool to conduct performance analysis and optimize the hypersonic air breathing vehicles, [Alberico, 1992]. This tool was able to assess the the performance between flight conditions such as speed and altitude.

In 1996, in a thesis study in METU Arslan [Arslan, 1996] coupled direct collocation optimization technique with nonlinear programming. This technique was applied to a trajectory optimization problem of air-to-air missile configuration. Maximizing range was selected as objective function in this study.

Low Observables Design Synthesis Tool (LODST), which is a system design tool for the conceptual design phase, was created by Bennett, [Bennett, 1997]. Both the analytical and semi-empirical methods are used to predict the propulsion system design characteristics, missile aerodynamics and mass budgeting in LODST.

In another thesis study in METU, Utalay [Utalay, 1999] used hide and seek simulated annealing as optimization algorithm. In this study three different single – objective optimizations were performed. Maximizing range, minimizing time of flight and minimizing weight were those objectives.

In 2000, in another thesis study in METU, Bingöl [Bingöl, 2000] applied hide and seek simulated annealing algorithm to multi-disciplinary design optimization of missiles. The design optimization includes disciplines of flight mechanics, aerodynamics, propulsion and structures.

In her thesis Soyluoğlu [Soyluoğlu, 2001] investigated the application of genetic algorithm to missile trajectory optimization problem. Both maximum range trajectory optimization problem and specified range minimum flight time problem were formulated and solved using genetic algorithm. A hypothetical air-to-surface missile was used with given launch conditions and specified impact conditions. The results obtained were compared to the results obtained by simulated annealing algorithm.

Ender *et al.*, [Ender *et al.*, 2002] conducted further studies on the conceptual design of hypersonic missiles at the Aerospace System Design Laboratory (ASDL) of Georgia Tech. In this tool, it is not possible to handle subsonic mid-range cruise missiles or guided munitions.

In a thesis study, Aytar-Ortaç in METU [Aytar-Ortaç, 2002] focused on the conceptual design of unguided missiles. Maximum range, minimum dispersion and maximum warhead effectiveness were chosen as the objectives. Gradient based and genetic algorithms were used and the results of these different algorithms were compared. As a result of this study, it was shown that the performance of the genetic algorithm is much better compared to gradient based algorithms.

In 2004, in another thesis study in METU, Karslı [Karslı, 2004] used Multi Objective Hide and Seek Simulated Annealing as optimization algorithm. Two different multi – objective optimization is performed in this study. Objective functions were maximizing range and minimizing time of flight in first optimization whereas maximizing insertion mass and maximizing velocity were the objective functions of the second optimization performed.

Compared to past examples, the primary improvement in Tanıl's thesis study in METU [Tanıl, 2009] was that it dealt with air-to-air, air-to-ground and surface to surface missile optimization with a 3 DOF simulation based on Genetic Algorithm. Thus, it allowed finding the ideal outer geometry among a broad range of options in much shorter time periods that satisfies the predefined flight task.

The aim of another study by Öztürk in METU [Öztürk, 2009] was to develop a tool which runs together with a simulation algorithm so that it allows for evaluation of many design parameters and outputs the Pareto-optimal solutions for the corresponding design variables. Multiple Cooling – Multi Objective Simulated Annealing (MC-MOSA) algorithm was modified and applied to several missile design optimization problems.

In another study by Yang [Yang et al., 2010] a shape optimization study was performed to maximize the range of a guided missile with canards and tailfins.

In another thesis study in METU, Dede [Dede, 2011] utilized both simulated annealing and genetic algorithms individually and a hybrid algorithm, which is a combination of these two approaches. For all three optimization methods, a trade-off study was handled in terms of computational time and solution accuracy. As objectives of the study, maximizing the range and minimizing the launch weight was selected. The tool developed was valid for turbojet powered air-to-ground missiles.

The aim of another study by Karakoç in METU [Karakoç, 2011] was multi-disciplinary design and optimization of an air-to-surface turbojet powered missile to find Pareto optimal solutions of external geometry configurations with circular and elliptical cross sectional shapes with the constraints of stability, control, weight and launch platform with the objectives of maximum flight range and minimum radar cross section area. Minimum radar cross section objective is important to include survivability issues in the design at the conceptual design phase.

Two different optimization algorithms are employed for the development of an optimization procedure in the thesis study by Arslan [Arslan, 2014]. Sequential Quadratic Programming (SQP) and Adaptively Controlled Random Search (ACRS) algorithms were considered for the investigation of optimum aerodynamic missile configuration. Maximizing range, maximizing maneuverability and minimizing hinge moments were the objective functions of this study.

The previous studies on missile aerodynamic design and optimization studies in literature is summarized in Table 1.3 and Table 1.4.

Table 1.3. Literature Survey Summary – Previous Studies before 2009

<b>Study</b>	<b>Type of Missile</b>	<b>Optimization Algorithm Used</b>	<b>Objective Functions</b>
[Arslan, 1996]	ATS	Direct Collcation	Trajectory Optimization: Max range (fixed missile configuration, launch and impact conditions)
[Bennett, 1997]	Arbitrary Body Shaped Missiles	No Optimization	Predictions: Propulsion system design characteristics Missile aerodynamics Mass budgeting
[Utalay, 1999]	ATS	Hide and Seek Simulated Annealing Algorithm	Single Objective Optimization: Maximize Range Minimize TOF Minimize Weight
[Bingöl, 2000]	ATS	Hide and Seek Simulated Annealing Algorithm	Multi-disciplinary Optimization: Maximize Range Minimize TOF (Fixed Range) Minimize Weight (Fixed Range)
[Soyluoğlu, 2001]	ATS	Genetic Algorithm	Trajectory Optimization: Maximize range Minimize Time (Fixed Range)
[Aytar-Ortaç 2002]	STS	Quasi-Newton Method, Genetic Algorithms	Multi-objective Optimization: Maximize Range Maximize Warhead Effectiveness Minimize Side Dispersion
[Karslı, 2004]	ATS, Launch Vehicle	Multi Objective Hide and Seek Simulated Annealing Algorithm	1 <sup>st</sup> Optimization: Maximize range and Minimize TOF 2 <sup>nd</sup> Optimization Maximize insertion mass and maximize velocity

Table 1.4. Literature Survey Summary – Recent Studies after 2009

<b>Study</b>	<b>Type of Missile</b>	<b>Optimization Algorithm Used</b>	<b>Objective Functions</b>
[Öztürk, 2009]	ATS	Multiple Cooling - Multi-Objective Simulated Annealing (MC-MOSA)	Multi-objective Optimization: Maximizing Range Maximizing Hit Angle and Velocity
[Tanıl, 2009]	ATS, STS, ATA Missiles	Genetic Algorithm	Minimizing Launch Mass Maximizing Range Maximizing Cruise Speed
[Yang <i>et al.</i> , 2010]	STS Guided Missiles	Genetic Algorithm	Maximizing Range
[Dede,2011]	Turbojet Propelled ATS	Simulated Annealing, Genetic Algorithm	Maximize Range Minimize Launch Weight
[Karakoç, 2011]	ATS, Turbojet Powered Missiles	Genetic Algorithm	Multi-disciplinary Optimization: Maximizing Range Minimizing RCS
[Arslan, 2014]	ATS	Sequential Quadratic Programming (SQP), Random Search	Maximize $n_{trim}$ (maneuverability) Maximize $C_L/C_{D@trim}$ (Range) Minimize Hinge Moment

#### **1.4. Objectives of the Thesis**

The number of aerospace applications, especially missile projects, has increased in recent years. In this rapidly developing area, several challenges affect the design phase. A few of these challenges such as; high time pressure, updating requirements for missiles during conceptual design phase and storage efficiency are the most influential ones.

In military projects, product delivery dates are very strict. For air force, navy and army forces, having those systems when they are needed is another important issue, together with having the suitable system for their operation concept (CONOPS). Therefore, the necessity to reduce the time spent on the conceptual design phase has aroused. In addition to the high time pressure, the end user often asks to update the requirements during the conceptual design phase.

Some outer geometry optimization studies and design tools, that aim to cope with these challenges, could be found by conducting the literature survey. However, it can be observed that none of these studies have taken into consideration the modularity of lifting surfaces. The most important aspect of modularity is the fact that it is very beneficial in widening the scope of operational concepts. In the meantime, it enables to carry out an operation with the most cost-effective missile that can fulfill the mission. Along with cost effectiveness, the modularity of lifting surfaces also increases the storage efficiency in the military bases, since only one body configuration needed to be stored, but it can be used as both versions, as the version with wings or strakes.

In this study, it is aimed to develop a design tool by using the Design of Experiment method and Genetic Algorithm based optimization method, that can optimize the gliding missiles' outer geometry while taking into consideration the modularity of lifting surfaces by investigating two different versions of the same configuration, create design alternatives, evaluate them and determine the optimum one. The objectives are selected to maximize lift-to-drag ratio at the trim condition in order to



increase the range and to maximize the maximum usable lift coefficient to contribute to the maneuverability of the missile.

The version with strakes is defined as the 1<sup>st</sup> version (Figure 1.3) whereas the version which has wings defined as the 2<sup>nd</sup> version (Figure 1.4).

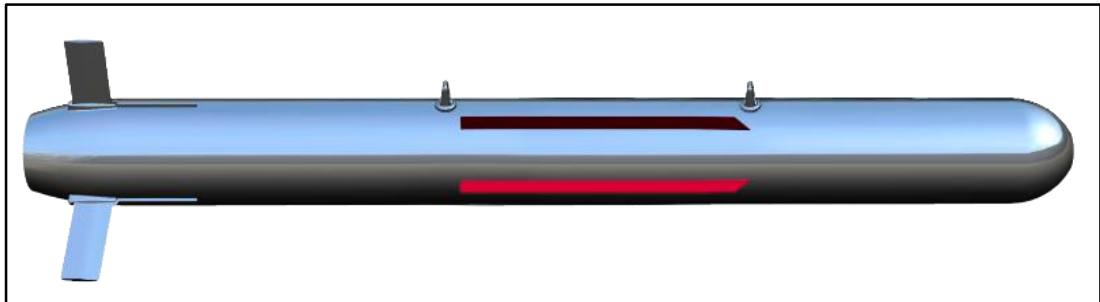

*Figure 1.3. 1<sup>st</sup> Version of the Missile (with strakes)*

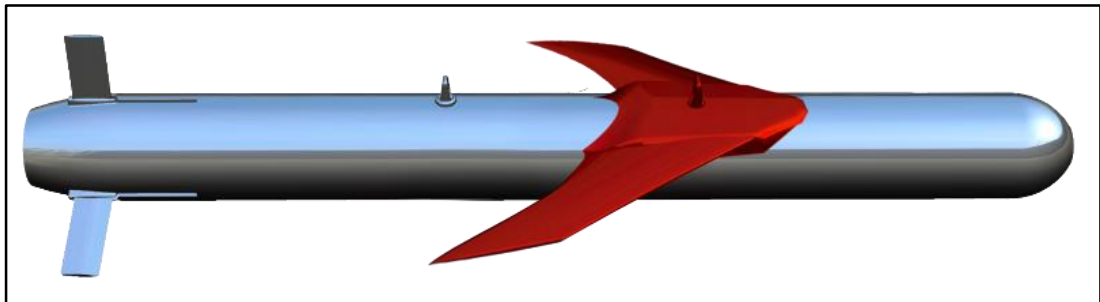

*Figure 1.4. 2<sup>nd</sup> Version of the Missile (with wings)*

To sum up, the aim of this thesis is to generate an optimization tool for multi-disciplinary design and optimization of air-to-surface, tail controlled gliding missiles, which have modular lifting surfaces. For this purpose, multi-disciplinary genetic algorithm and simplex algorithm are employed and their performances are compared with each other. Furthermore, both versions, with wings and with strakes, are also optimized individually to investigate the effect of optimizing both versions together on the performance. In other words, if the optimized configuration, that obtained for

both versions, creates a drastic negative effect on one of the performance parameters for an individual version, the designer can decide whether or not to choose this coupled optimized configuration. In this optimization study, important constraints such as platform integration, static stability and control effectiveness are taken into account for both versions of the missile.

### **1.5. Scope of the Thesis**

This thesis is made up of 5 chapters. Chapter 1 provides a background introduction to the subject of the thesis, including the goals of the research with a literature survey. The differences of this study from the previous ones and the contribution of this work to the literature are explained in this chapter.

Chapter 2 gives detailed information about the design methodology. The optimization method is mainly addressed in this chapter. The optimization procedure, the selected aerodynamic performance prediction code, the geometrical parameters selected to be optimized, and the design objectives and constraints are described in detail. Also, the Design of Experiment method and the optimization method using Genetic Algorithm are explained in this chapter.

The selected test case studies for the design of guided munitions (gliding missiles) are described in Chapter 3 to investigate the use of the design and optimization methodology. The results obtained for the test cases are presented in Chapter 4. Chapter 5, which is the final chapter of the thesis, gives an overview of this thesis study together with some recommendations for future work.

## CHAPTER 2

### DESIGN METHODOLOGY

#### 2.1. Design and Optimization Methodology

The design of a missile is an iterative process. A number of design iterations is required to achieve a balanced optimum design satisfying the design objectives. Together with fulfilling the performance requirements such as range and maneuverability, the design must also be compatible with the specified constraints such as total mass, stability, and control.

The optimization cycle starts with selecting the design objective functions and their weights against each other. For different mission and scenario definitions, different objectives may become more important. In conjunction with the objectives, also the constraints of the system should be defined at the beginning.

With some selected basic geometrical parameters, the outer geometry of a missile can be defined. It is computationally expensive to generate all possible outer geometries and analyze them. Therefore, some of these geometrical parameters can be fixed to a constant value before the optimization algorithm is run. The selection of these geometrical parameters may be changed for different systems.

By using the appropriate Design of Experiment (DoE) method, an initial design space is generated. By using DoE, the performance of the optimization algorithm can be maximized. After the initial design is evaluated, the optimization algorithm generates new designs with different values of parameters. All of the designs should be aerodynamically analyzed. For this purpose, USAF Missile DATCOM software [Blake, W. B, *et al.*, 2011] tool is used in this thesis.

During the design and optimization, the availability of each design should be checked and only unfeasible solutions should be eliminated. Then, aerodynamic performance data of alternative designs are compared with each other and a pareto optimum set is obtained for more than one objective. The design methodology tool developed in this thesis offers all of the mentioned steps above, and the design and optimization procedure is shown in Figure 2.1, and also shown in more detail in Figure A.1 in Appendix A.

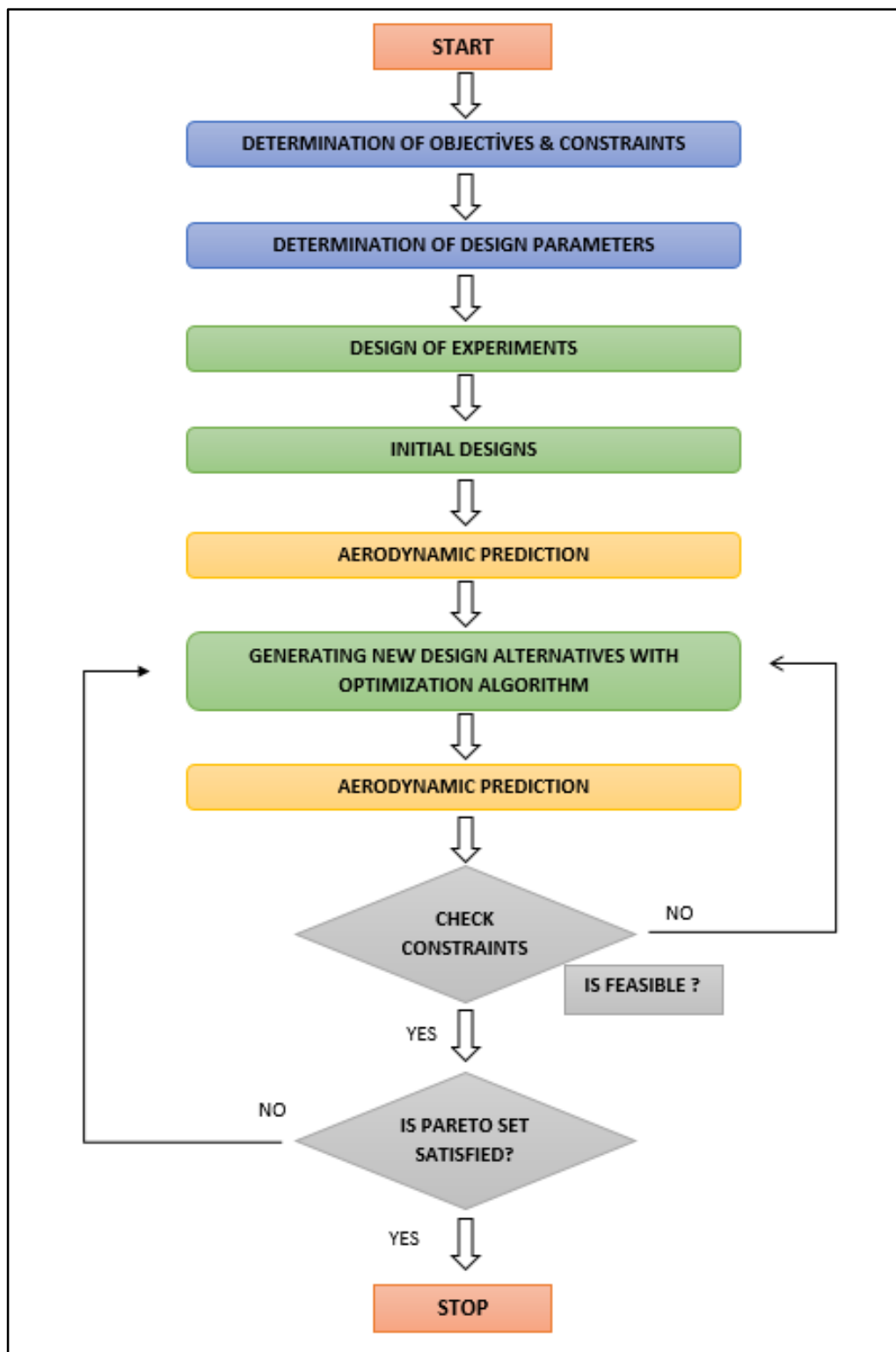

Figure 2.1. Design and Optimization Procedure

## 2.2. Optimization Platform

ModeFrontier [ModeFrontier, 2019] is a multidisciplinary design optimization platform which is used in this thesis. Its workflow-based environment and optimization algorithms help to reduce time spent in the design phase and to achieve enhanced outcomes.

ModeFrontier is divided into three environments as *Workflow Editor*, *Run Analysis*, and *Design Space*. *Workflow Editor* is the environment where the designer should create a logic workflow and graphically formulate the engineering problem. The workflow developed for this thesis is given in Appendix A. The second part, *Run Analysis*, consists of the evaluation or optimization of designs, as defined by the workflow. *Run Analysis* environment also enables real time monitoring of its progress. The last part, *Design Space*, is the part where the assessment and visualization of the results are done.

## 2.3. Determination of Aerodynamic Coefficients

When conducting conceptual design of a missile, it is important to estimate the aerodynamic performance accurately. Making this estimation fast and precisely enables the designer to evaluate the range of the missile, the size of the propulsion system, and the maneuverability of the missile.

Aerodynamic prediction codes enable a design tool to make a prompt estimation of the aerodynamic performance. These aerodynamic prediction codes apart from Computational Fluid Dynamics (CFD) simulations, employ semi-empirical methods instead of solving the full Navier-Stokes equations. Usually, a trade-off between the accuracy and the computational time occurs, and this is the main reason for the algorithms with different level of fidelity to be used [Tyan, *et al*, 2015]. Missile DATCOM, PANEL3D, SET3D, Aerodynamic Prediction Code (AP-XX) and

PRODAS V3 are some of the afore-mentioned aerodynamic prediction codes used in aerodynamic conceptual design phases in aerospace applications [Atik *et al.*, 2008].

Missile DATCOM is an aerodynamic performance tool generated to estimate the control characteristics and aerodynamic stability of missile configurations by employing both empirical and simple aerodynamic theoretical methods. Therefore, Missile DATCOM can be used for the speed regime from subsonic to hypersonic flight. In this study, Missile DATCOM software tool is used for the aerodynamic performance calculations.

### **2.3.1. Missile DATCOM Validation**

In 2008, Atik *et al.* [Atik *et al.*, 2008] performed a comparison study between a well-known semi empiric aerodynamic prediction tool, Missile DATCOM and a CFD flow solver, FLUENT. The aerodynamic analyses of missiles have been made for four different missile geometries (4 different models) and for several configurations at different flight conditions with the Mach number range of  $M = 0.6 - 4.6$ . The fin-on and fin-off conditions, the various yaw and roll deflections were investigated as different configurations of the missiles. The aerodynamic coefficients, such as both lateral ( $C_l, C_n, C_Y$ ) and longitudinal ( $C_L, C_D, C_m, C_N, C_A$ ) coefficients, were obtained for various angle of attacks. It was concluded that, although the CFD simulations give better results in some conditions, semi empiric codes may be an alternative to CFD solvers especially when the large simulation time was taken into consideration. Longitudinal aerodynamic characteristics of one model, both for 0.7 and 1.2 Mach numbers, is shown as an example in Figure 2.2.

In addition to Atik's study mentioned before, various other studies have been carried out to reveal the capability and reliability of Missile DATCOM. As result of these studies Missile DATCOM has proved itself and has a wide usage both in industry and academic studies [Maurice, 2009], [Hong, 2008]. Also in this thesis, Missile DATCOM software tool is used for the aerodynamic performance calculations.

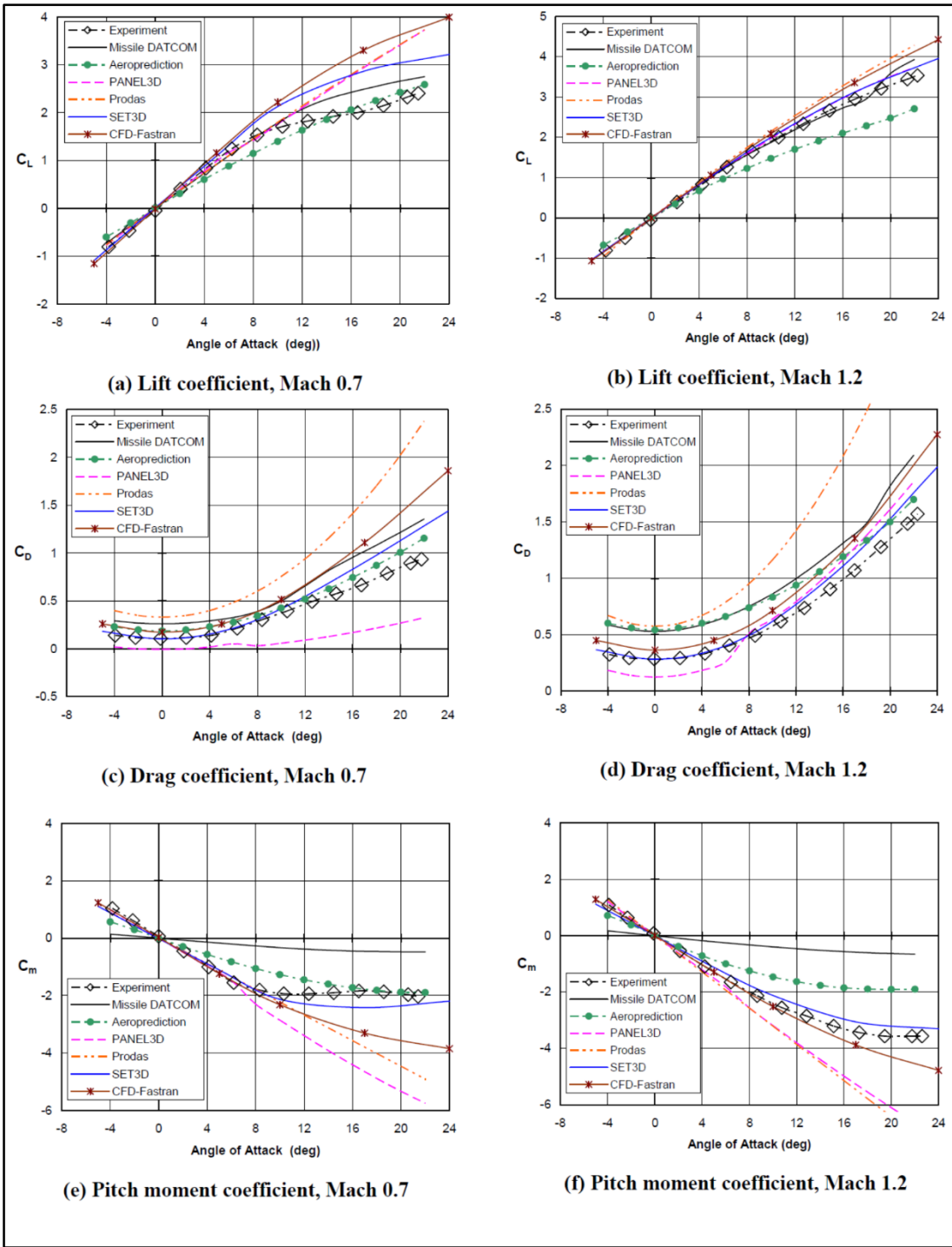

Figure 2.2. Longitudinal Aerodynamic Coefficients of Example Model [Atik et al., 2008]



### **2.3.2. Missile DATCOM Properties**

The code was initially released in August 1984. Having said that, there have been a lot of versions that altered the original code throughout the years. The last 4 versions and the enhancements of the code are given in Appendix B [Blake *et al.*, 2011]. The version that has been utilized for this thesis is Version 03/11.

Missile DATCOM employ text-based input and output files both to define the model and to give the results of the aerodynamic calculations. These input and output files are summarized in Appendix C [Blake *et. al*, 2011]. User-defined Mach number vector, angle of attack vector and the external geometry parameters are used as the input set by Missile DATCOM. In this design study, the angle of attack is defined between  $0^\circ$  and  $10^\circ$ , and the Mach number is given between the range of 0.1 and 1.2 sternly with guided munitions flight regime. The angle of attack and Mach number may change with respect to the mission profile. The physical constraints, which limits the bounds of external geometrical parameters of the missile, can be set according to the aircraft to which the designed missile is integrated, the subsystem needs and/or the missile structural properties.

### **2.4. Design Parameters and Missile Geometry**

Missile DATCOM, as an aerodynamic performance prediction tool, requires the flight conditions and the missile geometry to perform the aerodynamic analysis. Flight conditions, such as altitude, speed or Reynolds number depend on operational concept. The designer can decide the speed range and the altitude range that the missile will confront. Missile outer geometry on the other hand, is the main driver that affects the missile's performance and should be optimized.

Outer geometry of a missile can be defined with some specific geometrical parameters. These parameters are given in Table 2.1 and some of them shown in Figure 2.3. Apart from the given parameters, the thickness to chord ratio and the fraction of chord from

the leading edge should be defined as parameters for both upper and lower surfaces if the airfoil type is a hexagonal or circular arc. They are shown in Figure 2.4.

Table 2.1. *Missile External Geometry*

Name of Parameter	<i>Explanation of Parameter</i>
FROLL	Fin Roll Orientation - “X” or “+” Orientation
TNOSE	Nose Shape - “Ogive”, “Cone”, “Power”, “Haack” or “Karman”
DNOSE	Nose Diameter at Base
LNOSE	Nose Length
BNOSE	Nose Bluntness Radius
LCENTR	Center Length
DCENTR	Center Diameter
TAFT	Aft Body Shape - “Cone” or “Ogive”
LAFT	Aft Body Length
DAFT	Aft Body Diameter at base
XLE_W	Wing (Strake) Leading Edge Position From Nose
SSPAN_W	Wing (Strake) Semi-span
CROOT_W	Wing (Strake) Root Chord
CTIP_W	Wing (Strake) Tip Chord
SWEEP_W	Wing (Strake) Sweep Angle
XLE_T	Tail Leading Edge Position From Nose
SSPAN_T	Tail Semi-Span
CROOT_T	Tail Root Chord
CTIP_T	Tail Tip Chord
SWEEP_T	Tail Sweep Angle
XCG	Center of Gravity in X Axis
TAIR	Airfoil Type

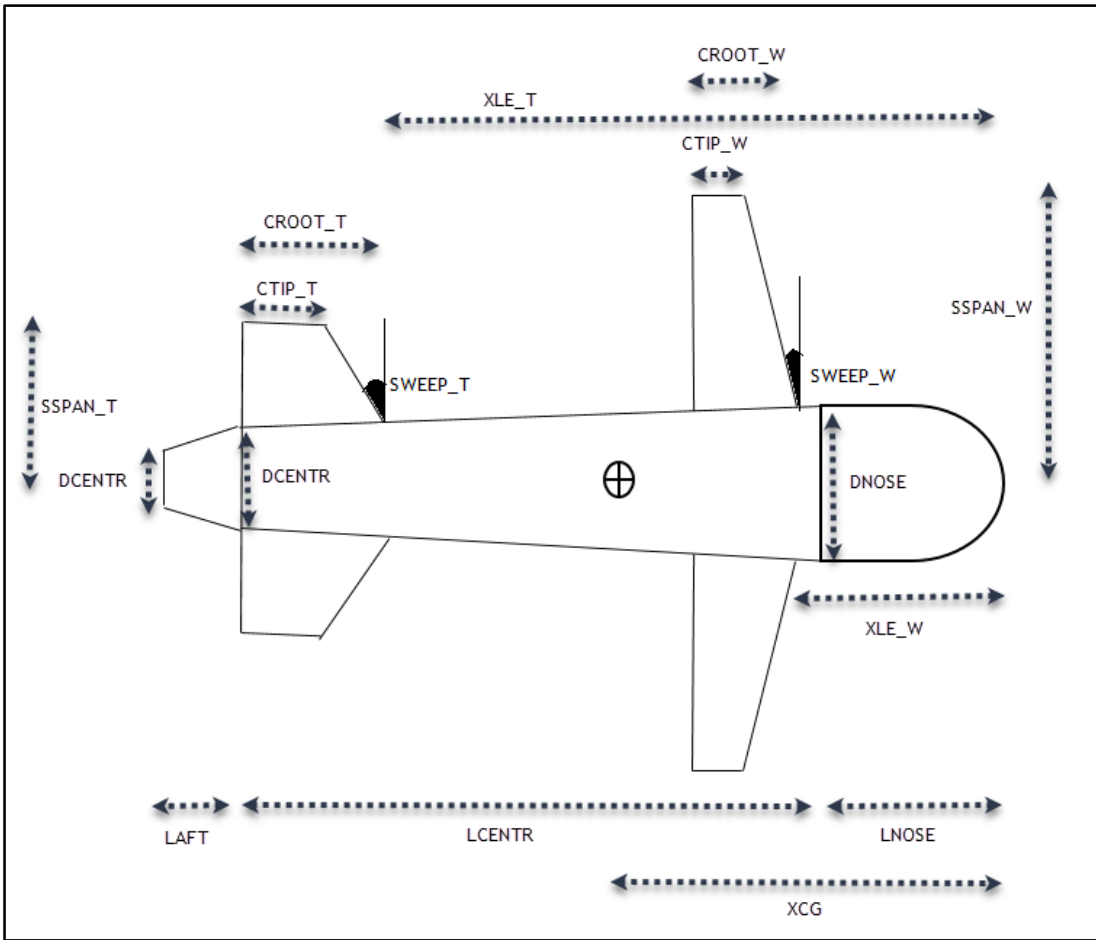

Figure 2.3. Missile Body External Geometry

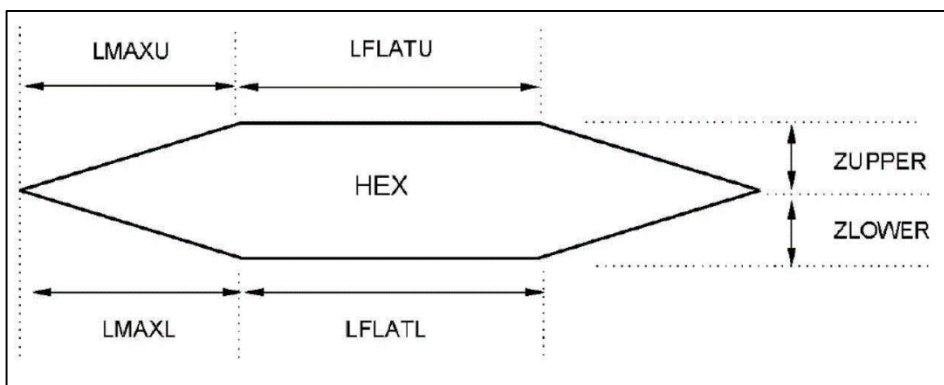

Figure 2.4. Variables of Hexagonal Airfoils [Blake, W. B, et al., 2011]

### 2.4.1. Nose Types

The geometric shape of the nose is an important component of missile's total drag. Nose length, nose diameter and nose bluntness are considered as design parameters along with the type of nose in the scope of this thesis.

The nose diameter and the nose length are two geometric parameters to be optimized. As generally confronted in existing systems, in this thesis the nose diameter at its base is considered as equal to the missiles body diameter.

The nose of a missile can be either truncated or blunted. The general shapes of both a blunted nose and a truncated nose are shown in Figure 2.5. In order to reduce drag, to avoid a sharp point due to manufacturing and safety reasons; the nose of a missile should be blunted spherically with a radius equal to 0.1 to 0.2 times the maximum body diameter according to the standards [MIL-HDBK-762, 1990].

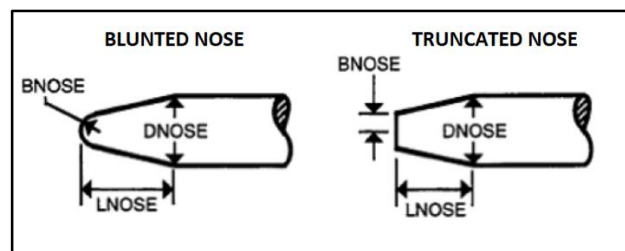

Figure 2.5. Truncated and Blunted Missile Noses [Blake, W. B, et al., 2011]

The conical type, tangent ogive type, power type, Haack and Von Karman types are the alternative nose shapes that can be modeled in Missile DATCOM [Blake, W. B, et al., 2011]. Definitions and mathematical equations of these nose types are defined in the literature. For all nose cone shape equations;  $LNOSE$  stands for the overall length of the nose cone,  $R$  is the nose radius. Other variables are  $x$  and  $y$ , axial and radial distances, where  $x$  stands for the axial distance and varies from 0, at the tip of the nose cone, to  $LNOSE$ , and  $y$  is the radius of the nose at any point  $x$ . The equations,

defining a two dimensional profile will be given later in this section. By rotating this profile around the centerline, the full body of revolution of the nose cone can be formed [Crowell, 1996]. In Figure 2.6, these variables are shown.

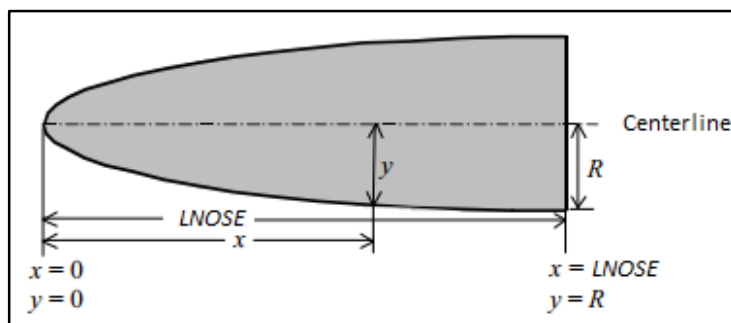

Figure 2.6. Dimensional Parameters used in Nose Type Equations [Crowell, 1996]

The conical nose type, which is a simple cone, is an alternative for the nose cone type. Generally, it is chosen for its ease of manufacturing. The sides of the conical shape are straight lines as shown in Figure 2.7.

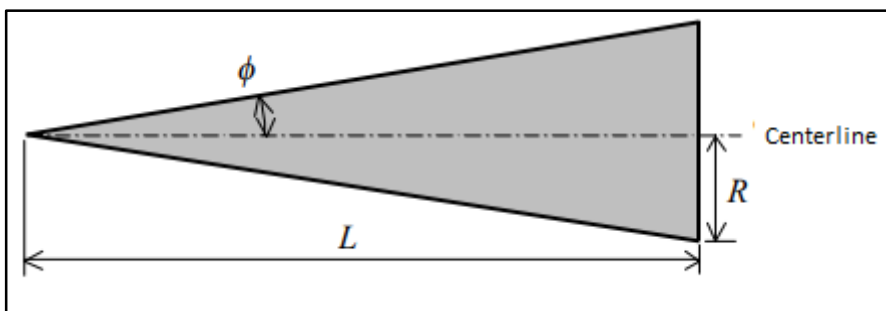

Figure 2.7. Conical Nose Cone Geometry [Crowell, 1996]

The conical nose can be defined by their ‘half angle’,  $\phi$  as:

$$\phi = \tan^{-1} \left( \frac{R}{L} \right) \text{ and } y = x \tan(\phi) \quad (2.1)$$

A special case of power series can also define a cone, which will be described later.

The ogive nose type is the most frequently used type of nose due to its advantages compared to the conical type. Having slightly greater volume for a given nose fineness ratio and base, structural superiority due to having a blunter nose, having a low drag profile, and its ease in production are the advantages of ogive type of noses. The profile of this shape is formed by a segment of a circle such that the body is tangent to the curve of the nose cone at its base. Ogive radius ( $\rho$ ) is the radius of the circle that forms the ogive. In Figure 2.8. the shape of the tangent ogive nose cone is shown. The ogive radius is given with the following expression:

$$\rho = \frac{R^2 + LNOSE^2}{2R} \quad (2.2)$$

In addition, the variable  $y$ , radius at any point  $x$ , is defined as:

$$y = \sqrt{\rho^2 - (LNOSE - x)^2} + R - \rho \quad (2.3)$$

The nose length must be either equal or less than the ogive radius. In case nose length and ogive radius are equal then the shape of the nose is a hemisphere.

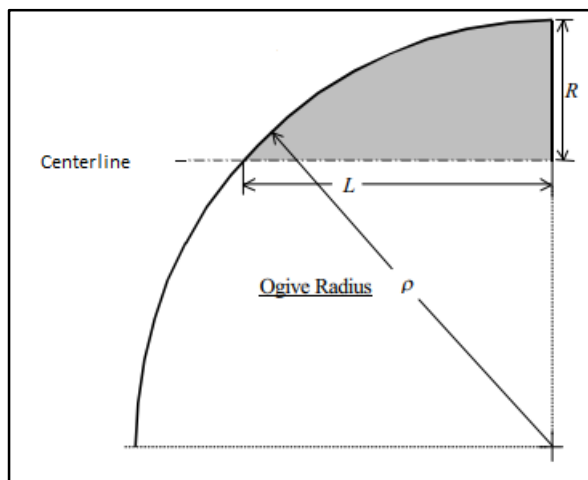

Figure 2.8. Tangent Ogive Nose Cone Geometry [Crowell, 1996]

Another alternative for nose type is the power series. Usually, the shape of the power series is characterized by its blunt tip. The nose geometry is defined with the following equation:

$$y = R \left( \frac{x}{L_{NOSE}} \right)^n \text{ where } 0 \leq n \leq 1 \quad (2.4)$$

The factor  $n$  controls the bluntness of the shape. The profiles of the nose cones for different factor  $n$  is given in Figure 2.9.

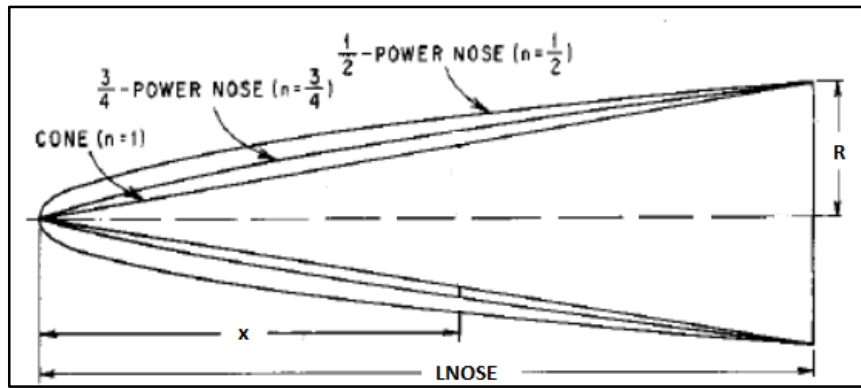

Figure 2.9. Power Nosecone Geometries, [Chin, 1961].

Haack and Von Karman series are mathematically derived expressions as given below:

$$y = R \sqrt{\frac{1}{\pi} \left( \theta - \frac{\sin(2\theta)}{2} + C * \sin(\theta^3) \right)} \quad (2.5)$$

where,

$$\theta = \cos^{-1} \left( 1 - \frac{2x}{L} \right) \quad (2.6)$$

For Haack series constant  $C$  is equal to  $1/3$  and for Von Karman series  $C$  is equal to  $0$ . Haack Series indicates minimum drag for a given nose length and volume whereas, Von Karman series indicates the same for a given nose length and a diameter at the base.



### 2.4.2. Roll Orientation

Both for stability and control effectiveness, the roll orientation of the missile fins is the most important factor. There are two main approaches for the symmetric roll orientation during missile flight. These approaches are plus and cross, “+” and “x”, configurations and both have their own benefit and drawbacks. In Figure 2.10 these configurations and their maneuver control deflection alternatives are shown [Fleeman, 2001].

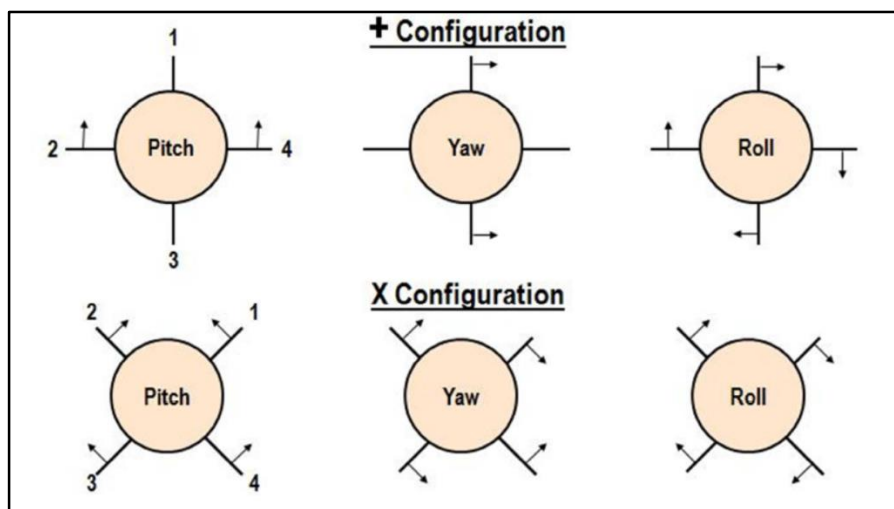

Figure 2.10. Roll Configuration and Maneuver Control Deflection Alternatives [Fleeman, 2001]

The main advantage of “+” configuration is to have a simpler control mechanism. Also, the “+” configuration usually has an advantage in terms of reduced trim drag. Two horizontal surfaces provide normal force in the pitch direction for pitch motion. For yaw control, on the other hand, two vertical surfaces provide side force in the yaw direction. All four surfaces have to be deflected in the clockwise direction in order to roll in the clockwise direction. Similarly, the opposite is valid for the counter-clockwise roll. A drawback of this plus configuration is that it generally has a statically unstable rolling moment derivative, ( $C_{l_\theta} > 0$ ).

Alternatively, the “x” configuration during missile flight is more complicated in its control mechanisms. Both for yaw and pitch controls, each of the four surfaces has to be deflected, in a different way from the “+” configuration. For roll control, it is similar with “+” configuration and all four surfaces are deflected to provide a roll moment for the missile. The “x” configuration generally has benefits of better compatibility with a launch platform, greater aerodynamic effectiveness, higher lift-to-drag ratio, and a statically stable rolling moment derivative with respect to roll angle,  $\theta$ , ( $C_{l\theta} < 0$ ).

### 2.4.3. Wing / Tail Section Considerations

There are some alternative surface planform geometries for missile tails, wings or strakes. These alternatives can be classified as triangular (delta), trapezoidal, forward-swept trapezoidal and rectangular planforms. The advantages and disadvantages of all geometries are summarized in Table 2.2 [Fleeman, 2001].

Table 2.2. *Surface Planform Geometry Alternatives [Fleeman, 2001]*

Parameter	<i>Triangular</i>	<i>Trapezoidal</i>	<i>Rectangle</i>
Variation $X_{AC}$	Very Good	Good	Average
Bending Moment	Good	Average	Bad
RCS	Very Good	Good	Bad
Required Span	Bad	Good	Good
Control Efficiency	Average	Very Good	Average

The triangular surface geometry has many benefits such as having a small change in aerodynamic center, low radar cross section, and high structural stiffness. Unfortunately, along with these advantages, the triangular surface geometry requires larger spans which generally exceeds the launch platform span limit.

## 2.5. Design Objectives

Obtaining a baseline external geometry and a configuration which satisfies the requirements of the flight is the aim of the conceptual design phase. The relationship between design objectives and conceptual design parameters shall be well defined and modeled. Design objectives are functions of design variables and constitute the outputs of the system. By changing the design variables, design objectives can be maximized or minimized.

One of the design objectives of this thesis is maneuverability. Design variable that affects the maneuverability is the maximum usable lift coefficient ( $C_{L_{max\_usable}}$ ). In order to maximize maneuverability, the lift coefficient shall be increased. Maneuverability is a more important asset for the first missile version with the strakes (V1) than for the second version with wings (V2) because of the fact that the second version has more time to fly towards the target.

The other design objective used in this study is range. To maximize the range, the design variable that shall be increased is the Lift-to-Drag ratio at the trim condition,  $(C_L/C_D)_{@trim}$ . The main reason to add wings to the basic configuration of the missile is to increase range. Therefore, the range is more important for the second version with wings (V2) than it is for the first version with strakes (V1)

Because of the above mentioned reasons, the two objective functions are defined as follows:

$$OBJ 1 = C_{L_{max\_usable}} = P1 * C_{L_{max\_usable}}(V1) + P2 * C_{L_{max\_usable}}(V2) \quad (2.7)$$

where,  $P1 = 0.7$  and  $P2 = 0.3$  as weighting factors for the first objective selected for this study, and

$$OBJ 2 = (C_L/C_D)_{@trim} = P1*(C_L/C_D)_{@trim}(V1) + P2*(C_L/C_D)_{@trim}(V2) \quad (2.8)$$

where,  $P1 = 0.3$  and  $P2 = 0.7$  as weighting factors for the second objective selected for this study.

In multi-objective optimization problems instead of the best solution, pareto optimal sets exist. If none of the objective functions can be improved without degrading other objective value, that solution is known as pareto optimal solution. Based on this definition, in this study, for multi objective optimization trials pareto optimal solution sets are constituted.

Multi-objective problems can be converted into single objective optimization problems by optimizing a weighted sum of the objective functions. Simplex Algorithm is also used to test and compare the optimization algorithms. Although the weighted sum method is simple to implement, the results of the optimizations are highly depending on the weights selected. In this study the weights of the objective functions are selected as equal, and the objective function to be optimized by simplex algorithm is given by:

$$\text{OBJ FUNC} = W1 \times \text{OBJ 1} + W2 \times \text{OBJ 2} \quad (2.9)$$

where,  $W1 = 0.5$  and  $W2 = 0.5$  as weighting factors for this single objective function.

### **2.5.1. Lift to Drag Ratio at Trim Condition**

A guided munition is a special kind of missile that has no propulsion system. As a result, the motion of guided munitions is defined as gliding motion. By using the basic trigonometry and balances of forces, the range can be found roughly with ease as follows:

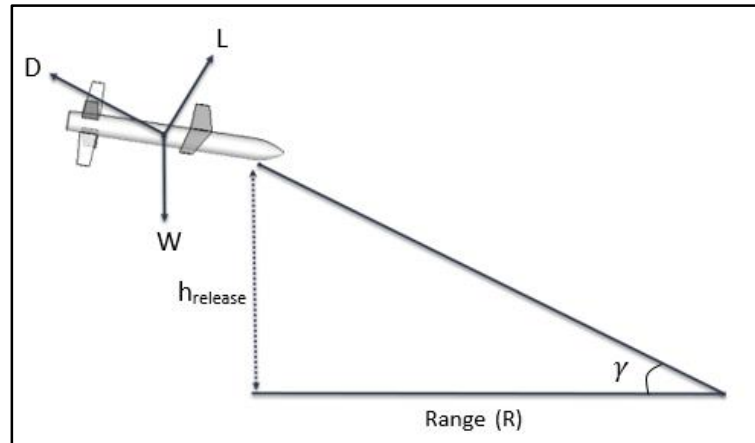

Figure 2.11. Vector Balance of Forces and Flight Path for Gliding Missiles

From trigonometry:

$$\tan \gamma = \frac{h_{\text{release}}}{R} \quad (2.10)$$

From balances of forces:

$$L \cos \gamma + D \sin \gamma = W \quad (2.11)$$

and

$$L \sin \gamma = D \cos \gamma \quad (2.12)$$

$$\tan \gamma = \frac{1}{L/D} \quad (2.13)$$

From these equalities,

$$\tan \gamma = \frac{h_{\text{release}}}{R} = \frac{1}{L/D} \quad (2.14)$$

where,

$$\frac{L}{D} = \frac{C_L}{C_D} \quad (2.15)$$

Finally,

$$R = C_L/C_D * h_{release} \quad (2.16)$$

As a gliding missile's Lift-to-Drag ratio is often given at the trim condition, the equation can also be expressed as:

$$R = C_L/C_{D @trim} * h_{release} \quad (2.17)$$

Therefore, according to given equation at the conceptual design phase, it is meaningful to specify one of the objectives as to maximize the maximum Lift-to-Drag ratio at trim condition for maximum range. Trim condition is different for all Mach numbers. Each of these trim conditions for each Mach number should be analyzed.

### **2.5.2. Maximum Usable Lift Coefficient**

There are four forces acting on a missile which are weight, thrust, lift and drag. For maneuverability of any missile lift and thrust are the main forces that can be used. There is no propulsion system in a guided munition as stated before. Therefore, for any maneuver the missile can solely use the component of lift force. The lift coefficient ( $C_L$ ) represents the ratio of the lift force to the force produced by the dynamic pressure times the area as given below.

$$C_L = \frac{L}{q * A} \quad (2.18)$$

The peak point of the lift coefficient vs angle of attack (AoA) curve represents the maximum lift coefficient ( $C_{L_{max}}$ ). A generic positive cambered " $C_L$  vs AoA" curve is given in Figure 2.12.

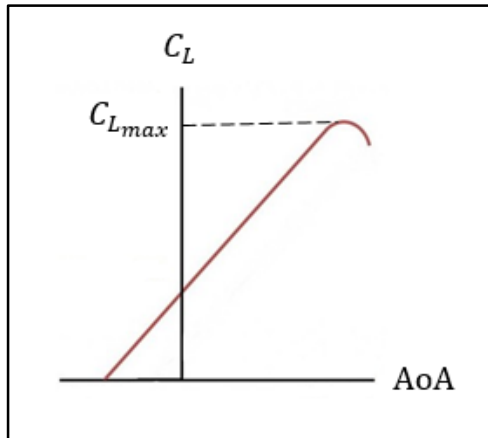

Figure 2.12 . Lift Coefficient vs AoA Curve

However, this  $C_{Lmax}$  value may not be used in order to avoid stability problems caused by the influence of non-linear aerodynamic characteristics. The maximum values of  $C_L$ , that can be obtained without confronting any nonlinearities, are termed as maximum usable lift coefficient ( $C_{Lmax\_usable}$ ).

The most typical example of this non linearities is the large local gradient changes of static stability as a function of AoA, so called local pitch up [Osterhuber, 2011]. A qualitative example of a local pitch up, strong localized change in pitching moment derivative ( $C_{m\alpha}$ ) with respect to angle of attack,  $\alpha$ , is given in Figure 2.13.

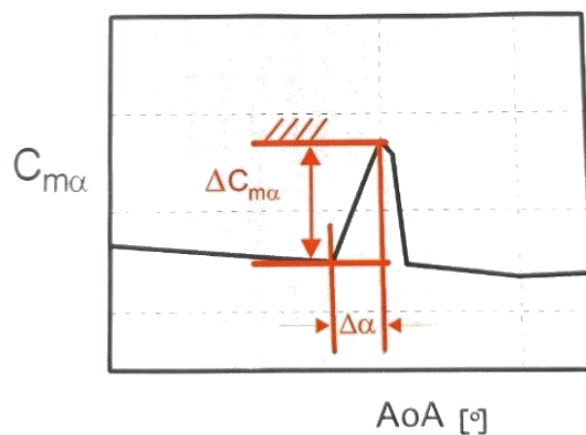

Figure 2.13. Local Pitch Up [Osterhuber, 2011]

In order to avoid the influence of nonlinear aerodynamic characteristics the necessary condition is given as:

$$dC_{m_\alpha}/d\alpha \leq 0.1 \quad (2.19)$$

The point where the local gradient of static stability exceeds 0.1 is the upper limit for the angle of attack of missile. This AoA limit may be different for different Mach Numbers. An example matrix demonstrating the usable lift coefficients ( $C_{L_{usable}}$ ) in green fillings is given in Figure 2.14.

	$\alpha=0^\circ$	$\alpha=1^\circ$	$\alpha=2^\circ$	$\alpha=3^\circ$	$\alpha=4^\circ$	$\alpha=5^\circ$	$\alpha=6^\circ$	$\alpha=7^\circ$	$\alpha=8^\circ$	$\alpha=10^\circ$
<b>M = 0.1</b>	$C_L=xx$	$C_L=xx$	$C_L=xx$	$C_L=xx$	$C_L=xx$	$C_L=xx$	$C_L=xx$	$C_L=xx$	$C_L=xx$	$C_L=xx$
<b>M = 0.3</b>	$C_L=xx$	$C_L=xx$	$C_L=xx$	$C_L=xx$	$C_L=xx$	$C_L=xx$	$C_L=xx$	$C_L=xx$	$C_L=xx$	$C_L=xx$
<b>M = 0.5</b>	$C_L=xx$	$C_L=xx$	$C_L=xx$	$C_L=xx$	$C_L=xx$	$C_L=xx$	$C_L=xx$	$C_L=xx$	$C_L=xx$	$C_L=xx$
<b>M = 0.6</b>	$C_L=xx$	$C_L=xx$	$C_L=xx$	$C_L=xx$	$C_L=xx$	$C_L=xx$	$C_L=xx$	$C_L=xx$	$C_L=xx$	$C_L=xx$
<b>M = 0.7</b>	$C_L=xx$	$C_L=xx$	$C_L=xx$	$C_L=xx$	$C_L=xx$	$C_L=xx$	$C_L=xx$	$C_L=xx$	$C_L=xx$	$C_L=xx$
<b>M = 0.8</b>	$C_L=xx$	$C_L=xx$	$C_L=xx$	$C_L=xx$	$C_L=xx$	$C_L=xx$	$C_L=xx$	$C_L=xx$	$C_L=xx$	$C_L=xx$
<b>M = 0.9</b>	$C_L=xx$	$C_L=xx$	$C_L=xx$	$C_L=xx$	$C_L=xx$	$C_L=xx$	$C_L=xx$	$C_L=xx$	$C_L=xx$	$C_L=xx$
<b>M = 1.0</b>	$C_L=xx$	$C_L=xx$	$C_L=xx$	$C_L=xx$	$C_L=xx$	$C_L=xx$	$C_L=xx$	$C_L=xx$	$C_L=xx$	$C_L=xx$
<b>M = 1.1</b>	$C_L=xx$	$C_L=xx$	$C_L=xx$	$C_L=xx$	$C_L=xx$	$C_L=xx$	$C_L=xx$	$C_L=xx$	$C_L=xx$	$C_L=xx$
<b>M = 1.2</b>	$C_L=xx$	$C_L=xx$	$C_L=xx$	$C_L=xx$	$C_L=xx$	$C_L=xx$	$C_L=xx$	$C_L=xx$	$C_L=xx$	$C_L=xx$

Figure 2.14. Usable Lift Coefficients Matrix

Maximum usable lift coefficient ( $C_{L_{max\_usable}}$ ); is the maximum among all the lift coefficients that the missile can have within the AoA and Mach Number Limits.

Consequently, to enhance the maneuverability, maximizing the usable lift coefficient has a great importance for guided munitions as stated above. Therefore, one of the objective functions of this study is to maximize the maximum usable lift coefficient ( $C_{L_{max\_usable}}$ ).



## 2.6. Design Constraints

During the design phase, there have to be some limitations known as design constraints. The design constraints are the conditions that need to be satisfied for a successful design. Designs which violate one or more constraints are called as unfeasible designs. It is important to take the design constraints into account at the conceptual design phase of a missile. The design constraints should be determined by the designer. Maximum or minimum values of design objectives, the total mass of the missile, stability of the missile etc. can be defined as the design constraints. The design constraints selected for this study are the static stability, the control effectiveness, physical and structural constraints related with the missile body fineness ratio and the platform integration, whose details will be given later in this chapter. The summary of the design constraints is given in Table 2.3.

Table 2.3. *Mathematical Expressions of Design Constraints*

Constraint Name	Limit
Static Stability	$C_{m\alpha} < 0$ $C_{m(\alpha=0^\circ)} < 0$
Control Effectiveness	$\frac{C_{m\delta}}{C_{m\alpha}} > 1$
Missile Body Fineness Ratio	$25 \geq \frac{Length}{Diameter} \geq 5$
Platform Integration Constraints	$Platform\ Capability \geq TotalLength$ $Platform\ Capability \geq WingSpan$ $Platform\ Capability \geq Diameter$

### 2.6.1. Static Stability Constraint

Static stability defines the initial tendency of a missile to return to its equilibrium state after being disturbed. A missile has both the lateral and longitudinal static stability.

Usually, the requirement for static lateral stability is mild [Etkin, *et al.*, 1996]. The longitudinal static stability, also known as static stability in the pitch axis, is one of the most important aerodynamic features of any missile. A statically stable missile produces some amount of pitching moment in the opposing manner of the disturbance. In other words, a positive change in the angle of attack causes a negative pitching moment which tends to decrease the angle attack [Etkin, *et al.*, 1996] [Fleeman, 2001].

The slope of the  $C_m$  vs  $\alpha$  (pitching moment coefficient vs angle of attack) graph defines the longitudinal static stability. The slope of the graph should be negative for static stability and  $C_m$  should be positive at a zero angle of attack to have a trim angle as shown in Figure 2.15. Mathematical expressions are given as follows:

$$C_{m\alpha} < 0 \tag{2.20}$$

$$C_{m\alpha=0^\circ} > 0 \tag{2.21}$$

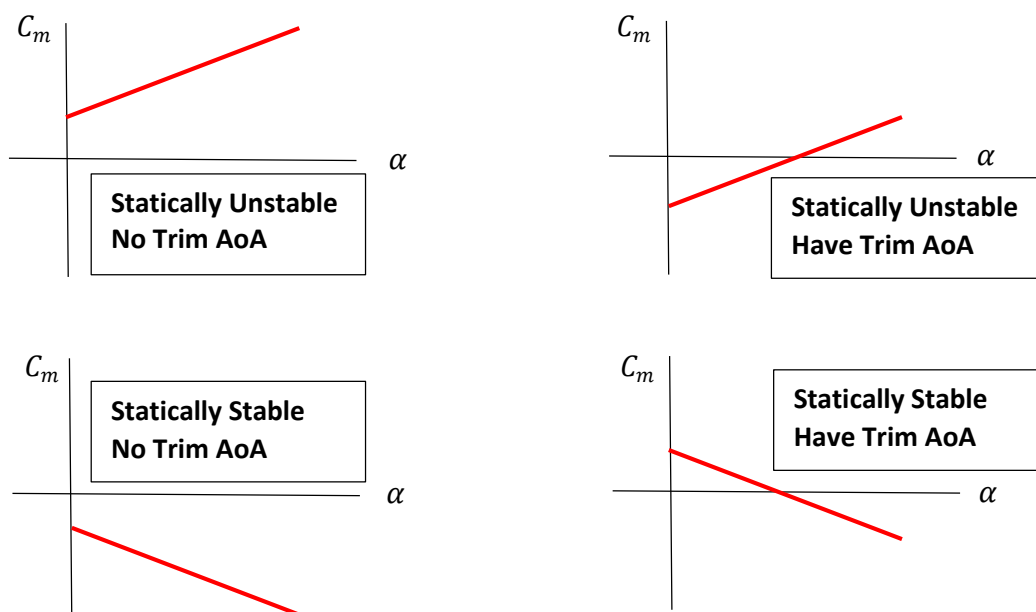

Figure 2.15.  $C_m$  vs  $\alpha$  Curves

The tail control is generally more effective for a statically stable missile at higher degrees of angle of attack. The local angle of attack at the tail is reduced with the deflection of the tail in order to trim the missile. The tail can be deflected to a high angle of attack without confronting the stall condition. In order to attain this phenomenon the center of the pressure ( $C_p$ ) should be closer to the tail than the center of gravity ( $CG$ ) as shown in Figure 2.16.

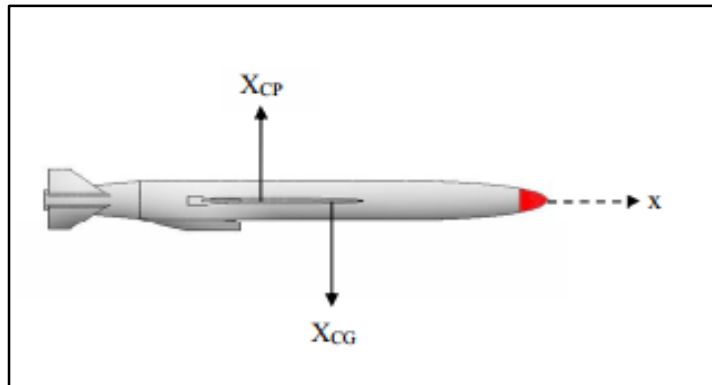

Figure 2.16.  $CG$  and  $C_p$  locations for a Statically Stable Missile

### 2.6.2. Control Effectiveness Constraint

Another vital parameter that has to be considered in the conceptual design phase is the control effectiveness. The effects of control surface deflections to roll, pitch and yaw angles of the missile are defined as controllability. The pitch axis is the main concern of this thesis, therefore, only the control effectiveness in the pitch plane is taken as a design constraint.

In order to have an adequate control margin, during the design of a tail controlled missile, it is a rule of thumb that the change in the angle of attack due to control deflection angle,  $\delta$ , should be greater than unity [Fleeman, 2001] as:

$$\frac{C_{m\delta}}{C_{m\alpha}} = \frac{\Delta C_m}{\Delta \delta} \frac{\Delta \alpha}{\Delta C_m} = \frac{\Delta \alpha}{\Delta \delta} > 1 \quad (2.22)$$

### 2.6.3. Structural and Integrational Constraints

In missile diameter trade-off study, there are some drivers both for small and large diameters. The lower drag and launch platform capability are the most important advantages of a smaller diameter. On the other hand, the increased range, the increased warhead effectiveness or the improved subsystem packaging for diameter limited subsystems are the leading factors for a larger diameter.

These mentioned reasons and their consequences must be harmonized. For a typical range of missiles, the length to diameter ratio is given between 5 to about 25. Therefore, the body fineness ratio (length to diameter ratio) is taken as a structural constraint [Fleeman, 2001] as:

$$5 \leq \textit{missile body fineness ratio} \leq 25$$

Missiles together with stores should be compatible with platforms and weapon support equipment. Some space constraints are needed to be specified in order to ensure adequate clearance during the worst-case dynamic flight maneuvers. During the design phase of the missile, these platform constraints and the clearances must be considered according to the standards [MIL-STD-1289 CH1, 2004]. These constraints can be formulated generally in the following manner:

$$\begin{aligned} \textit{Platform Capability} &\geq \textit{TotalLength} \\ \textit{Platform Capability} &\geq \textit{WingSpan} \\ \textit{Platform Capability} &\geq \textit{Diameter} \end{aligned}$$

The maximum outer dimensions for a typical missile, for a generic platform, are shown in Figure 2.17.

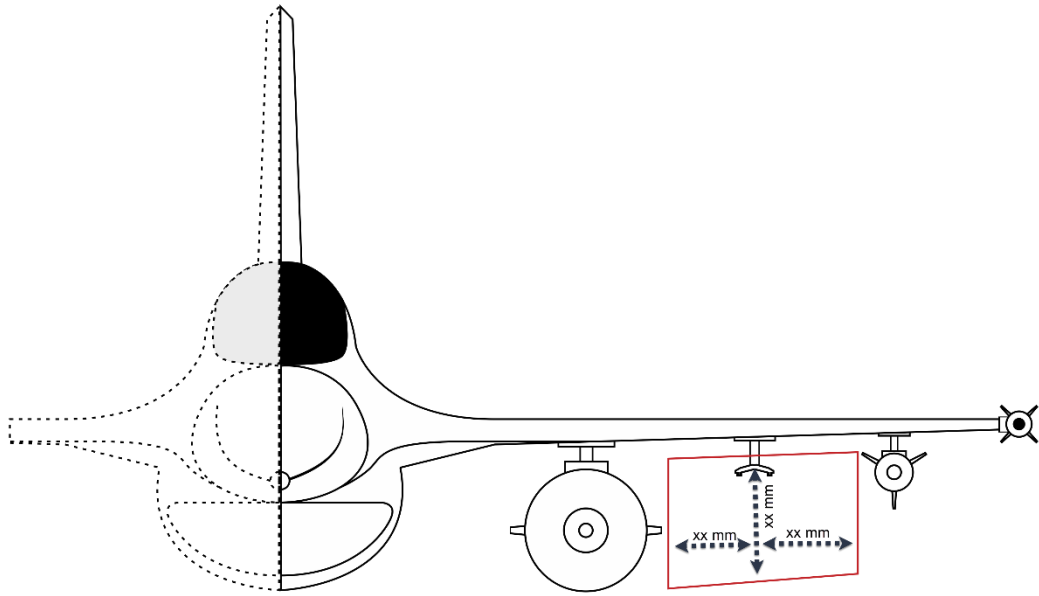

Figure 2.17. Outer Dimension Limits for a Typical Missile

## 2.7. Design of Experiments

For modern optimization studies, using the Design of Experiment (DoE), a formal and efficient approach, is a necessity. It is a systematic approach proposed by Fisher [Fisher, 1971] in the 1920s to obtain the maximum knowledge gained from experimental data, thus leading the way to extracting the most relevant information with minimum effort. Contrary to the traditional approach, which is changing one parameter at a time, the DoE method, considers changing several variables simultaneously. This method is more useful and efficient to analyze the effects of input parameters on output parameters than the traditional approach [Fisher, 1971].

The DoE can be used to identify the starting set of designs required by the optimization algorithm, thus maximizing the performance of the algorithm chosen. The DoE analyzes the interactions between the system variables and the system itself. Furthermore, it verifies the robustness of the optimization algorithm, defined as the

ability to reach the absolute extreme of the objective function instead of sticking in the local extremes [Fisher, 1971; Oehler, 2010].

In this thesis, the Sobol Algorithm [Sobol, 1967] has been used as the DoE method. The Sobol Algorithm is one of the efficient space filling techniques based on a pseudo-random numbers generator. The goal of the algorithm is to sample the design space uniformly. The pseudo-random sequence of Sobol was first introduced in 1967 for Monte Carlo integration by Sobol [Sobol, 1967]. The generators of pseudo-random numbers are mathematical series that generate sets of numbers that can pass the randomness tests. The Sobol Algorithm is a deterministic algorithm that mimics the random sequence behavior. In Sobol Algorithm, unlike the Random Sequence Algorithm, the clustering effects of experiments are reduced, that enables a better uniformity as shown in Figure 2.18 [Savine, 2019]. As it can be seen from the figure, the Sobol Algorithm covers the functions domain better than the other algorithm.

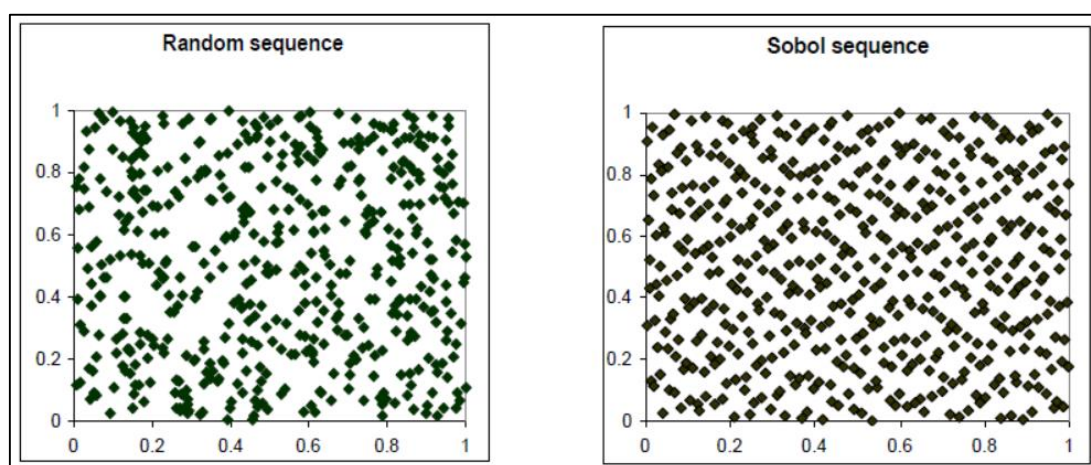

Figure 2.18. Comparison of Sobol and Random Sequences [Savine, 2019]

## 2.8. Optimization Algorithm

Optimization algorithms are used to find the best available option under certain constraints and evaluate the design trade-offs. Optimization algorithms compare the alternatives iteratively until an optimum solution is found. There are two main optimization algorithm types which are deterministic and stochastic algorithms. In deterministic algorithms, the parameter values and initial conditions completely determine the output; while in stochastic models initial conditions and parameters lead to different group of outputs because of the inherited randomness. Deterministic methods take benefit of the problem's analytical characteristics to produce a series of points converging to an ideal global solution. Heuristic approaches are more flexible and efficient in real life applications due to their applicability to problems with discontinuities [Lin, M. H., *et al.*, 2012].

Methods like Powell Method and Gradient-based Method can be classified as deterministic algorithms. On the other hand, Simulated Annealing method and Genetic Algorithm are stochastic methods by their nature. Genetic Algorithm method have recently shown promising results in solving multi-objective design problems and are easily implemented compared to the deterministic methods [Wang and Damodoran, 2000]. Genetic Algorithm has already proved itself in multi-objective optimization with several studies, by finding good solutions in reasonable amount of time [Cantu-Paz, 2001]. Although the conventional deterministic algorithms may also be alternatives for search algorithms, they are not preferable for complex optimization problems. Thus, Genetic Algorithm is used in this thesis.

The differences of Genetic Algorithm (GA) from the deterministic algorithms are summarized below:

- Instead of parameters themselves, genetic algorithm work with parameter sets,
- It needs a population defined instead of a single point to start,
- As the genetic algorithm only works with the objective function itself but not its derivative.

### 2.8.1. Multi – Objective Genetic Algorithm

Often, real world problems have more than one objectives, which are conflicting amongst themselves most of the time. This type of problems shall be treated as multi-objective problems. In general, there are two fundamental approaches to the multi-objective optimization: classical methods and evolutionary methods.

The classical methods fuse the competing objectives into a single function. The difficulty of these methods is the fact that the parameters are set by the optimizer and selecting the weights accurately may be challenging for most of the design problems. The Weighted Sum Method or The Constraint Method can be listed among various methods which are setting examples for this weighting technique. [Zitzler E., 1999].

The second approach is to use the evolutionary algorithms, mainly the Genetic Algorithms. The concept of Genetic Algorithms is inspired by the evolutionary theory, where the mechanism of the reproduction and natural selection are used to reach the fittest solution. The fitness function is the function that the algorithm is trying to optimize to find the fitter (optimum) solution.

The customized Genetic Algorithms are especially useful for finding the optimum possible solutions to the multi-objective problems since they may evaluate various solutions in a single simulation. The solutions of the multi-objective problems using the Genetic Algorithm give rise to a set of trade-offs which is referred as the Pareto-optimal set. Each of these solutions are optimal, and without preferring one objective to another, none of the solutions is better than the others. [Fonseca and Fleming, 1993]. Although the process of Genetic Algorithm is random as in the nature, the level of probability can be determined in this algorithm [Goldberg, 1989].

As stated before, the Genetic Algorithms start with an initial set of individuals, referred as *population*. The necessary initial population is created by DoEs. Each individual in the population is called as *chromosome* and represents a solution to the optimization problem. In this thesis, each possible outer geometry of the missile can be referred as chromosomes. An individual is characterized by a set of parameters



(variables) known as *genes*. Body diameter, body length, configuration (+ or X), airfoil type etc. can be thought of as the genes. The genes are joined into a string to form the chromosome (solution). The terminology used in the Genetics Algorithm is taken from biology, and an example for gene, chromosome and population is shown in Figure 2.19.

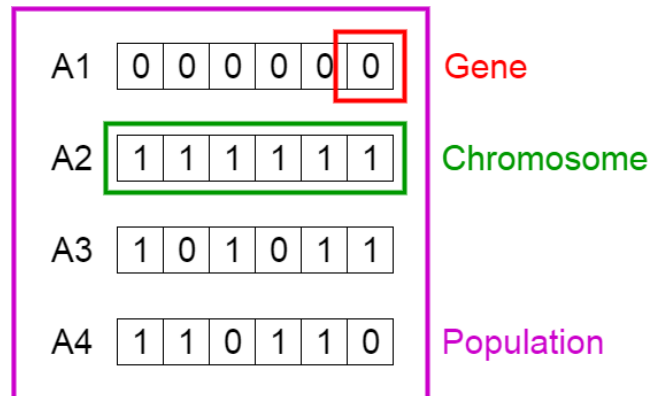

Figure 2.19. Gene, Chromosome and Population in Genetic Algorithm [Zitzler E., 1999]

Generally, there are four main operators of the evolutionary algorithms, known as the selection, crossover, mutation and elitism. A set of possible solutions is created randomly as a starting point and then the algorithm goes through a selection process. The selection is the Genetic Algorithm's primary inspiration in nature. In selection phase, the fittest individuals are selected and they have a higher possibility to pass their genes to the next generation. The selection is based on fitness score which is obtained by comparing the chromosomes. In this manner, the genes that encode the beneficial characteristics are propagated through the subsequent generations. Hopefully, the algorithm converges to an optimum solution after several generations [Gen and Cheng 1997].

Following the selection phase, the solutions are altered by either the crossover or the mutation or both, aiming to obtain new solutions from the existing ones. It can be considered as the most significant phase for the Genetic Algorithm. A crossover point is chosen randomly for each pair of parents to be combined to create a certain number of offspring. A new generation is created by exchanging the genes of the parents. The new offspring are

added to the population, leading the population to converge by making the chromosomes in the population similar to each other. The process of crossover is shown in Figure 2.20 [Zitzler E., 1999] [Konak A., Coit D. W., Smith A. E].

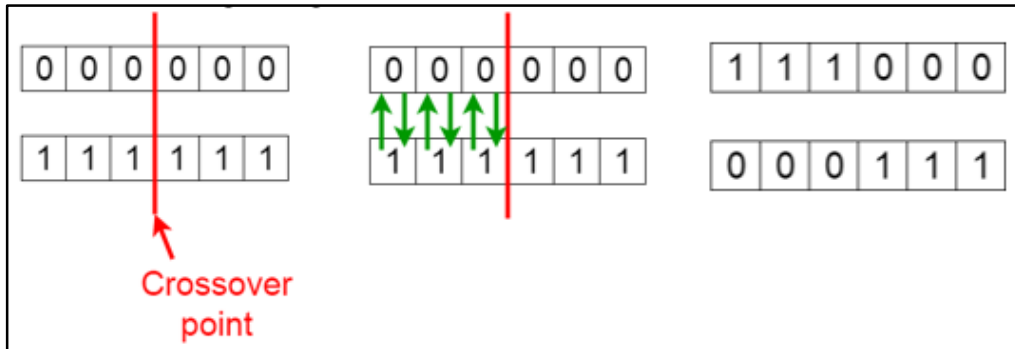

Figure 2.20. Crossover Process [Zitzler E., 1999]

The mutation, on the other hand, conducts random changes in the chromosomes at the gene level according to the given mutation rate. This means that the mutation introduces genetic diversity into the population. This also increases the robustness, the ability to reach the absolute extreme of the objective function of the algorithm. The natural evolution process may be perceived as an iterative process. The selection, crossover and/or mutation steps are repeated multiple times in order to refine the objectives until a suitable solution has been found. As the process matures, the population contains fitter and fitter solutions [Zitzler, 1999; Konak, *et al.* 2006].

The elitism is not an essential process of the Genetic Algorithm. The policy of elitism is to include the best individual of every generation into the next generation in order not to lose it due to sampling effects or operator disruption.

### 2.8.2. SIMPLEX Algorithm

Simplex Algorithm, [Poles, 2003], is a well-known algorithm used for solving non-linear multi-objective optimization problems. It is not based on the local gradients and this makes Simplex more robust. Because of the fact that the Simplex Algorithm

does not use derivatives, termination criteria does not depend on the gradient of the objective function. Instead, the algorithm terminates itself when it cannot find improved solutions.

Geometrically speaking, in an N-dimensional space, simplex is a polyhedron containing N+1 points. For example, it is a triangle in two dimensions and a pyramid in three-dimensions, and so on. When the points are equally distant from each other, simplex is regular. When they are not, it replaces one vertex which has high value compared to the other vertices and moves the polyhedron to the optimum point iteratively. Three movement options used by the simplex algorithm are; reflection, expansion and contraction. These three movement options are shown in Figure 2.21., Figure 2.22 and Figure 2.23 [Turco, 2011; Poles, 2003; Nelder *et al.*, 1965].

The reflection movement (Figure 2.21) is based on the method of mirroring the vertex that has the worst value compared to the others to the opposite side hence steering the function further away from the worst result and towards the optimum point. While the reflection method changes one point towards the opposite direction, the expansion method (Figure 2.22) decreases the function value by moving the reflected point further and further in the same direction as the mirroring. The contraction process (Figure 2.23) on the other hand, is practically the opposite of the expansion process. It is used when the new point obtained by the reflection method turns out to be worse than all the other vertices. By employing the same logic with the expansion method, the new point is moved to the opposite direction to the mirroring direction hence contracting the simplex.

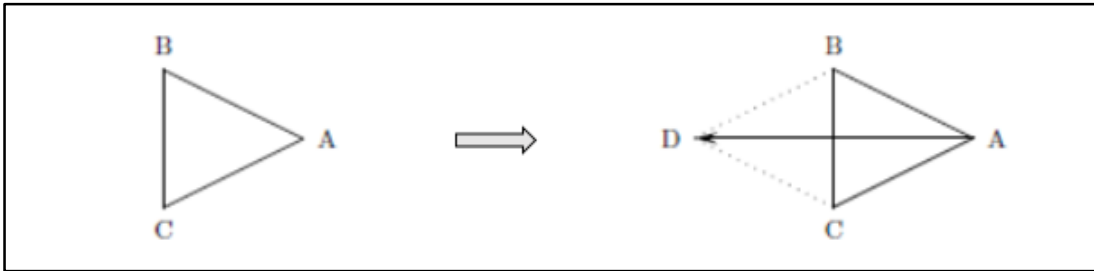

Figure 2.21. Reflected Simplex [Poles, 2003]

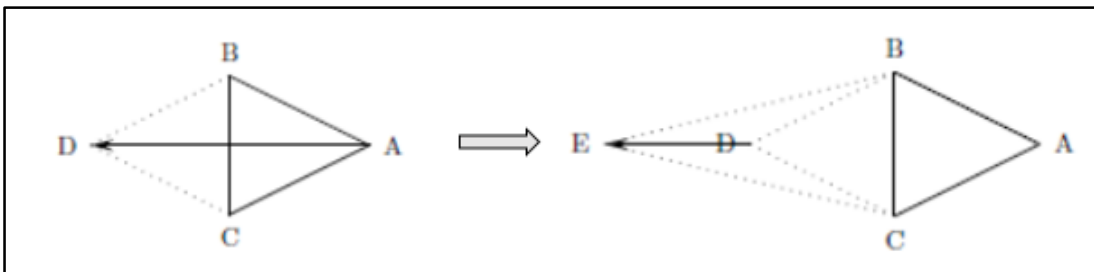

Figure 2.22. Expanded Simplex [Poles, 2003]



Figure 2.23. Contracted Simplex [Poles, 2003]

The simplex is initialized by  $N+1$  initial corners that are given by the first (`number_of_variables+1`) design configurations available in the DoE table. If the DoE table is empty or has less than  $N+1$  rows, the missing initial designs are randomly generated.

## **CHAPTER 3**

### **CASE STUDY**

For an application case study for a modular missile design, a generic 250 lb guided munition is chosen to be designed to test and investigate the design tool. The reasons for this selection are elaborated below.

The first reason is that 250 lb class munitions have smaller radar cross section (RCS) compared to other heavier class munitions due to its smaller weight. RCS is the measure of the reflected radar signals of a missile, or any target, in the direction of the radar receiver. In modern designs, other than flight performance, survivability should be considered to reach optimum design. Although having 250 lb warhead limits your warhead effectiveness, it helps to have smaller RCS [Karakoç, 2011].

Another important performance parameter for munitions is collateral damage. 250 lb precision guided variants munitions have the potential to reduce collateral damage compared to larger munitions.

Another important advantage of this class of munitions, is that they enable the multiple carriage with the help of ejector rack. Such a capability may be vital as it eases to attack various targets in a single sortie.

Lighter munitions also have minimum effect on platform performances. Although the aircraft may be able to carry higher loads, especially for trainers carrying such loads limits their abilities such as maneuverability, max ceiling, etc.

### 3.1. Design Parameter Limits

The physical constraints are the main factors to designate the upper and lower limits of the external geometry parameters. These external limits can be divided into four groups as the body parameters, wing parameters, strake parameters and tail parameters. The range of values that the external geometry parameters for the body, strake, wings, and tail can get are summarized in Table 3.1, Table 3.2, Table 3.3 and Table 3.4, respectively.

Table 3.1. *Limits of Body Parameters*

Parameter	Description	Lower Limit	Upper Limit
TNOSE	Nose Shape	Either Ogive or Cone	
LNOSE	Length of nose	0.1	0.3
BNOSE	Nose Bluntness	0.01	0.025
DNOSE	Nose Diameter	0.18 (Constant)	
LCENTR	Centerbody length	1.2	1.4
DCENTR	Centerbody Diameter at base	0.18 (Constant)	
TAFT	Aft Body Shape	Either Ogive or Cone	
DAFT	Afterbody Diameter at base	0.15	0.17
LAFT	Length of afterbody	0.15	0.4
XCG	Center of Gravity in X Axis	0.45*(LNOSE + LCENTR + LAFT)	

In order to decrease the number of possible designs, thereby to reduce the time spent on optimization, some parameters can be fixed at the beginning. In this case study, the diameter of the missile fixed to 180 mm at the beginning. This value comes from both geometric constraints of the platforms so that the guided munitions can be used together, and the competitor study. Due to the volume requirements of the subsystems of the gliding missile, the diameter is required to be as large as possible.

The position of the center of gravity in x-axis is formulated with respect to the total length of the missile. It is an engineering judgement based on previous experiments. Also, the location can be optimized by reconfiguring and optimizing the interior design provided that the designer knows the weight of the subsystems that will be used.

Table 3.2. *Limits of Strake Parameters*

Parameter	Description	Lower Limit	Upper Limit
TAIR_S	Type of airfoil section of Strake	Constant (Hexagonal Type)	
SSPAN_S	Strake semi-span	0.05	0.2
CROOT_S / CTIP_S	Strake root chord	0.2	0.5
XLE_S	Distance from missiles nose to strake's chord leading edge	0.3	1.0
SWEEP_S (°)	Sweepback angle of strake	0.0	25
ZUPPER_S/ZLOWER_S	Thickness to chord ratio of upper/lower surface for hexagonal airfoil type	0.05	0.15
LMAXU_S/LMAXL_S	Fraction of chord from leading edge to max. thickness of upper/lower surface for hexagonal airfoil type.	0.2	0.45

Table 3.3. *Limits of Wing Parameters*

Parameter	Description	Lower Limit	Upper Limit
TAIR_W	Type of airfoil section of wing	Constant (NACA Type)	
SSPAN_W	Wing semi-span	0.5	0.9
CROOT_W	Wing root chord	0.08	0.25
CTIP_W	Wing tip chord	0.05	0.2
XLE_W	Distance from missiles nose to wing's chord leading edge	0.3	1.0
SWEEP_W (°)	Sweepback angle of wing	0.0	25

Type of airfoil is fixed as hexagonal both for strake and tail fins, whereas for wings NACA airfoil type is preferred. NACA-1-6-65-410 profile, which is a 6 series NACA airfoil, is selected for the wing airfoil section in this case study. Different selections could be made for different cases.



Table 3.4. *Limits of Tail Parameters*

Parameter	Description	Lower Limit	Upper Limit
TAIR_T	Type of airfoil section of Strake	Constant (Hexagonal Type)	
SSPAN_T	Strake semi-span	0.1	0.3
CROOT_T	Strake root chord	0.05	0.2
CTIP_T	Strake tip chord	0.03	0.15
XLE_T	Distance from missiles nose to strake's chord leading edge	1.5	1.75
SWEEP_T (°)	Sweepback angle of strake	0.0	25
ZUPPER_T/ZLOWER_T	Thickness to chord ratio of upper/lower surface for hexagonal airfoil type	0.05	0.15
LMAXU_T/LMAXL_T	Fraction of chord from leading edge to max. thickness of upper/lower surface for hexagonal airfoil type.	0.2	0.45

### 3.2. Optimization Trials

For the selected geometric limits and the aerodynamic constraints, the optimizations are performed to design the selected class of missile. The differences between the optimization trials; such as optimizing one version alone or two versions of the missile together, aiming one or more objectives to optimize, or using different optimization algorithms, will be presented and examined in this section.

For multi-objective optimization there are two approaches as mentioned before by using the weighted sum approach and the pareto optimal set. These two different approaches are also investigated for the selected case study in order to compare the performance of the optimization algorithms. In Table 3.5, several optimization trials that are performed for this case study are summarized.

Table 3.5. Optimization Trials

Trial No.	Optimization Algorithm	Objectives	Pareto Designs / Weighted Sum
I	MOGA	1) $C_{L_{max\_usable}}(p1*v1+p2*v2)$ 2) $C_L/C_D @trim(p1*v1+p2*v2)$	Pareto Designs
II	MOGA	$C_{L_{max\_usable}}(p1*v1+ p2*v2)$	Weighted Sum - One Design
III	MOGA	$C_L/C_D @trim(p1*v1+ p2*v2)$	Weighted Sum - One Design
IV	MOGA	1) $C_{L_{max\_usable}}(v2)$ 2) $C_L/C_D @trim(v2)$	Pareto Designs
V	SIMPLEX	$(C_{L_{max\_usable}} + C_L/C_D @trim)/2$	Weighted Sum - One Design

The 1<sup>st</sup> optimization trial includes both versions of the gliding missile which are the one with strakes and the one with wings together and aims to optimize both design objectives aforementioned (maximize  $C_{L_{max\_usable}}$  and maximize  $C_L/C_D @trim$ ). In this trial, Multi-Objective Genetic Algorithm (MOGA) is used as optimization algorithm.

The 2<sup>nd</sup> and 3<sup>rd</sup> optimizations are carried out by aiming to maximize only one of the objectives at a time; maximum lift to drag ratio at trim condition ( $C_L/C_D @trim$ ) or maximum usable lift coefficient ( $C_{L_{max\_usable}}$ ), respectively. Both in the 2<sup>nd</sup> and 3<sup>rd</sup> optimization trials, a modular design, which refers to the ability of using both versions with wings and strakes together, is optimized as in the 1<sup>st</sup> optimization trial. The optimization algorithm is also the same Genetic Algorithm. By comparing the results with the 1<sup>st</sup> optimization trial which focuses on multi-objective optimization, the effect of working with several objectives simultaneously over optimizing with only one objective is evaluated.

Optimizing the outer geometry of the missile that can be used with both strakes and wings may limit the capabilities of either version. In the 4<sup>th</sup> trial, a classical multi-objective optimization is constituted for a gliding missile with wings and the results are compared with the two version optimization carried out in the 1<sup>st</sup> optimization trial. As in the previous trials, the Genetic Algorithm (MOGA) is used in the 4<sup>th</sup> optimization trial as well. By keeping the possible variabilities in the optimization procedure such as the optimization algorithm and the objectives as in the 1<sup>st</sup> optimization trial, the effect of the modular design is studied. With this comparison the designer can decide whether or not to design a modular missile. This decision could be different for each case study and the requirements of the case.

In the 5<sup>th</sup> optimization trial, the aim is to investigate the effect of the optimization algorithm on the design. Although the Genetic Algorithm is a self-proved and reliable optimization algorithm, the Simplex Algorithm is expected to be faster than GA. Therefore, by choosing the suitable single objective function and changing the Genetic

Algorithm to Simplex Algorithm, the effects of these two optimization algorithms on the design are investigated.

## CHAPTER 4

### RESULTS

In this chapter, the results of the optimization trials described in Chapter 3 are given. Moreover, the results of different optimization trials are compared to each other and the differences between them are discussed in detail.

#### 4.1. Modular Design Multi-Objective Optimization with MOGA

The parameters for the optimization algorithms and the information for the DoE are given in Table 4.1. for the 1<sup>st</sup> optimization trial. In the Genetic Algorithm, 1000 designs, 20 generations with 50 design solutions in each generation, are created and evaluated with respect to the selected objectives and constraints.

Table 4.1. *DoE and Optimization Algorithms Parameters*

Parameters	Value
Number of Generations	20
DoE Number	50 ( <i>Sobol Algorithm</i> )
Probability of Directional Cross-Over	0.5
Probability of Selection	0.05
Probability of Mutation	0.1

As a result of this multi-objective optimization trial by using the Genetic Algorithm for the modular design, the resulting design solutions are obtained as feasible and unfeasible designs, and the scatter chart of  $C_{L_{max\_usable}}$  with respect to  $C_L/C_{D@trim}$  is shown in Figure 4.1. As there were many constraints, the unfeasible designs are more than the feasible solutions as expected. Also, the history graphics of the feasible designs for both objectives (OBJ1 and OBJ2) individually with respect to design ID are given in Figure 4.2 and Figure 4.3. Every individual design is given a number called as design ID. The increasing trend in the values of the objectives can be seen from graphs. Also, the genetic optimization algorithm can steer the designs such a way that as the generations pass, the majority of the designs become more feasible.

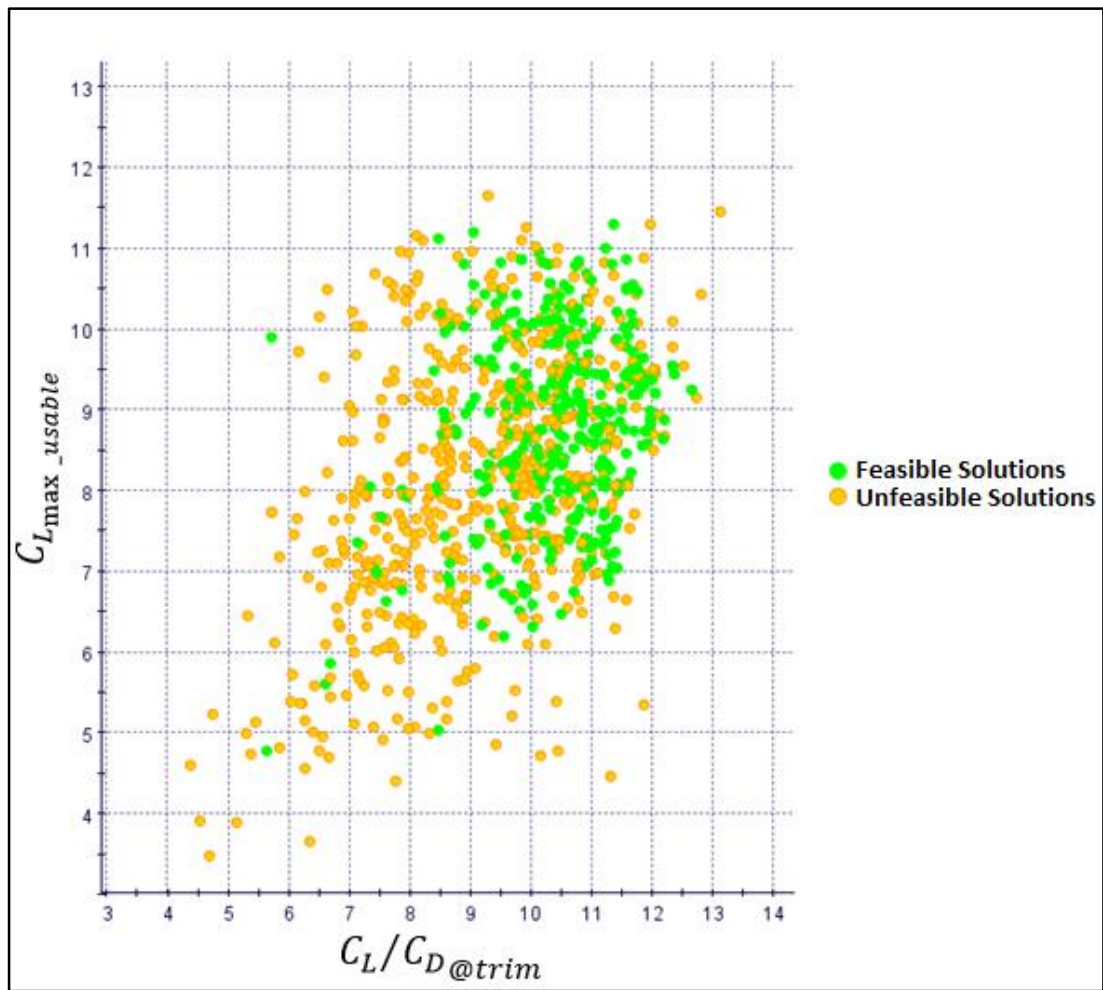

Figure 4.1. Scatter Chart:  $C_L/C_D@trim$  vs  $C_{Lmax\_usable}$

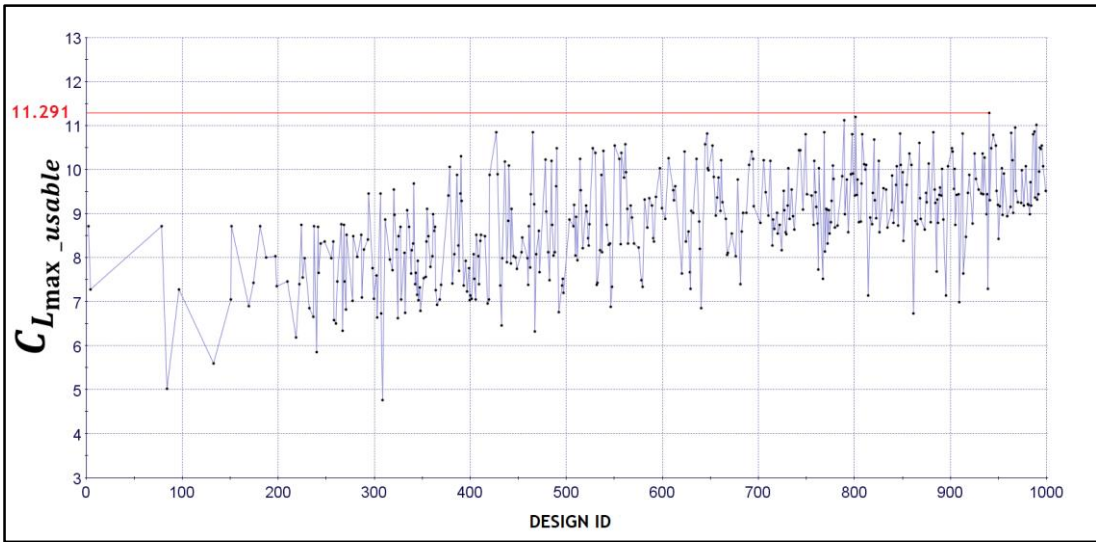

Figure 4.2. History Graphics of Maximum Usable Lift Coefficient (OBJ 1) (Trial I)

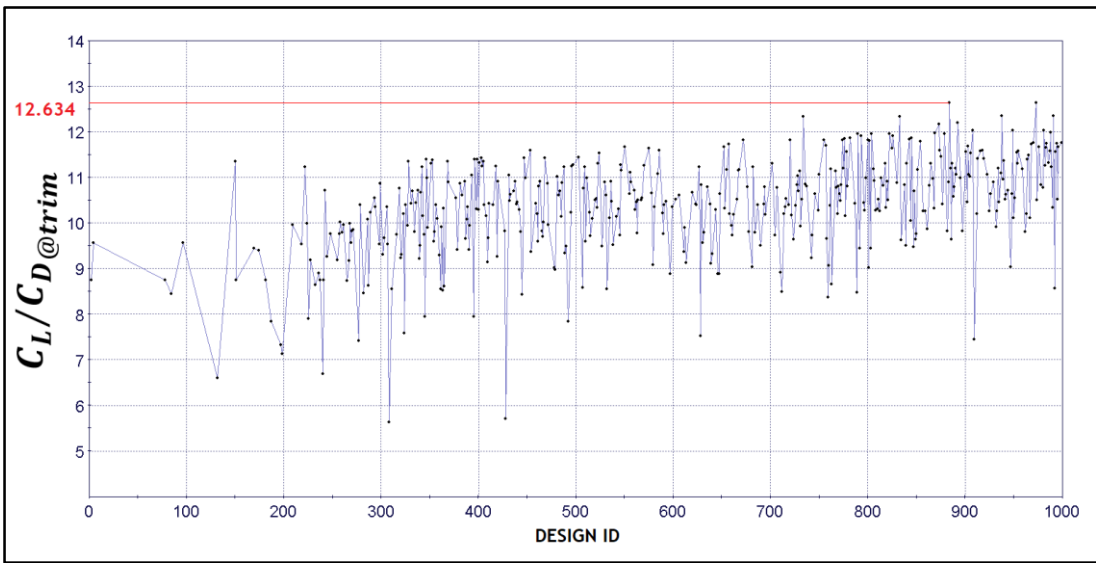

Figure 4.3. History Graphics of Lift-to-Drag Ratio at Trim Condition (OBJ 2) (Trial I)

The pareto optimal solutions of this optimization trial (Trial I) and the geometries of the optimum solutions are shown in Figure 4.4. and Figure 4.5.



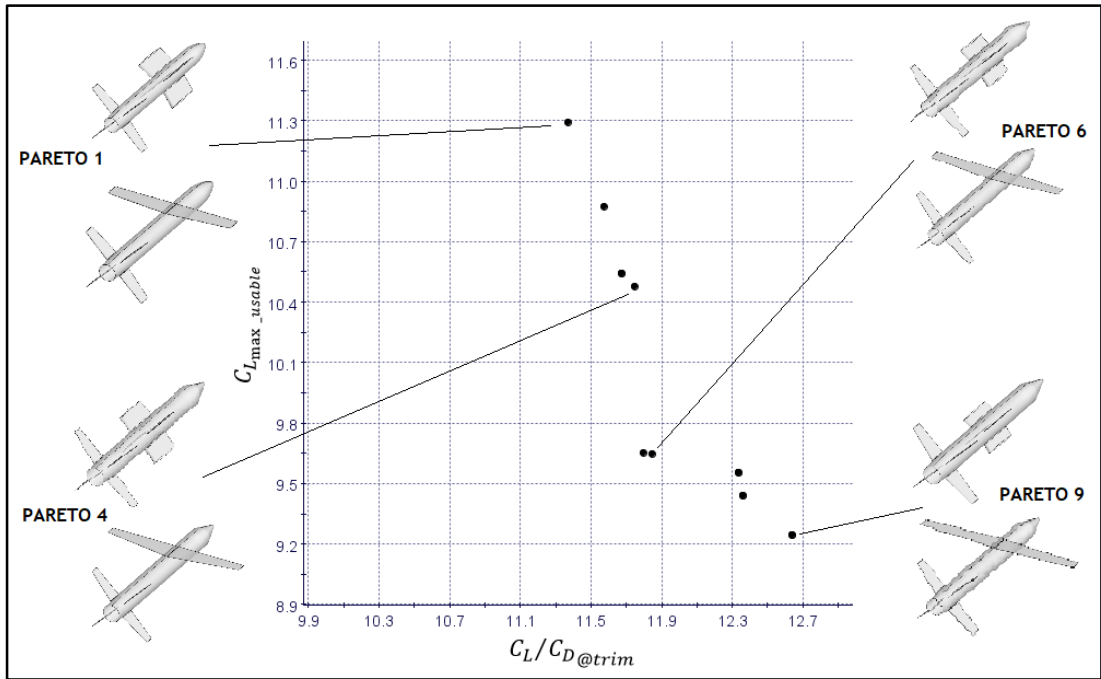
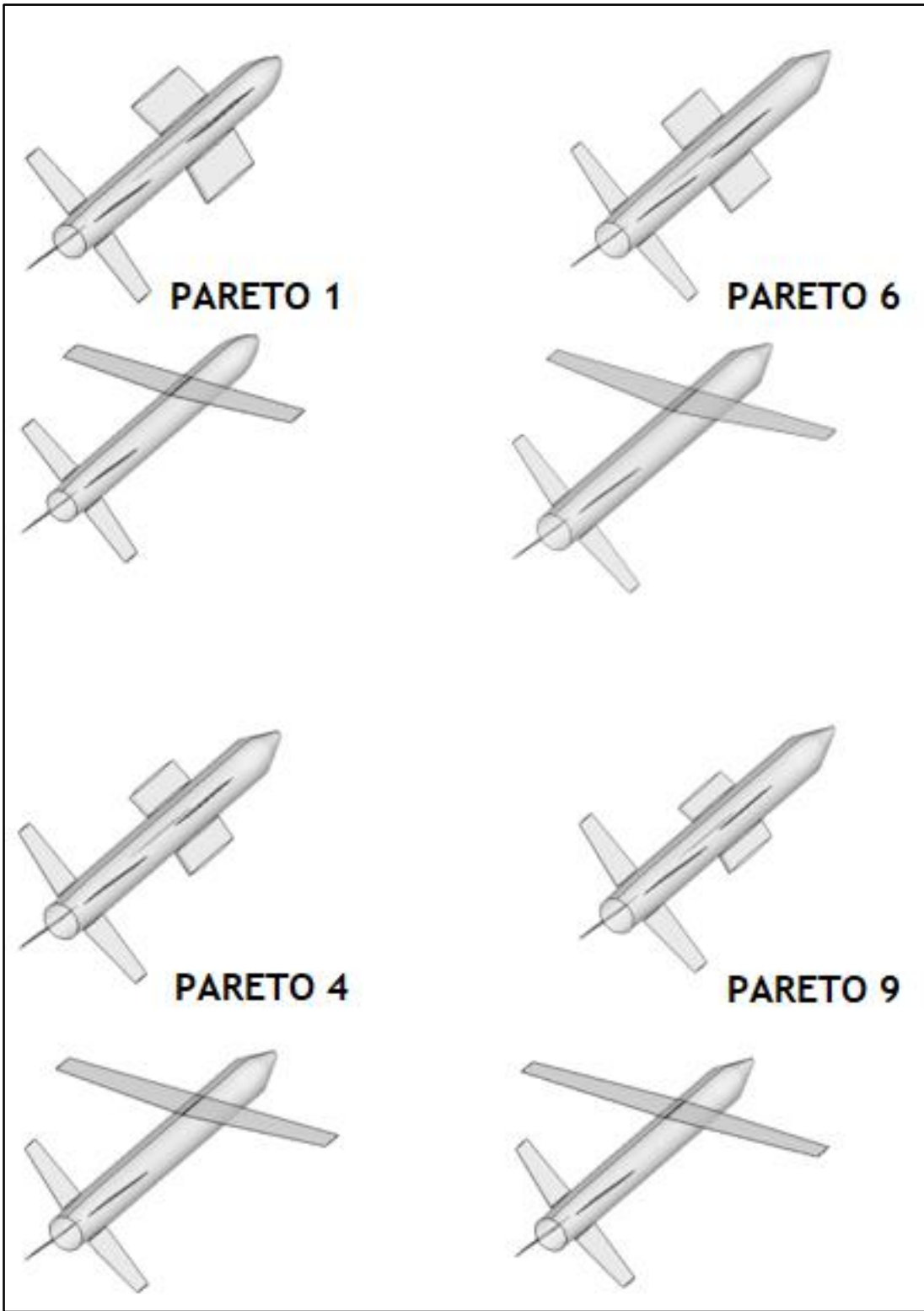

Figure 4.4. Pareto Optimum Solutions (9 Different Optimum Solution) (Trial I)



*Figure 4.5.* Geometries of Pareto Optimum Solutions (Trail I)

The numerical values of the objectives of pareto optimal solutions are given in Table 4.2. The 1<sup>st</sup> objective ( $C_{L_{max\_usable}}$ ) is the weighted sum of the  $C_{L_{max\_usable}}$  values of the missile versions with strakes (v1) and with wings (v2). Similarly the 2<sup>nd</sup> objective ( $C_L/C_D @trim$ ) is calculated with the same approach. The mathematical expressions of both objectives are given as follows:

$$OBJ 1 = C_{L_{max\_usable}} = (0.7 * C_{L_{max\_usable\_v1}} + 0.3 * C_{L_{max\_usable\_v2}})$$

$$OBJ 2 = C_L/C_D @trim = (0.3 * C_L/C_D @trim\_v1 + 0.7 * C_L/C_D @trim\_v2)$$

Table 4.2. Numerical Values of Objective Functions of Pareto Optimal Solutions (Trial I)

Optimal Solutions	OBJ 1 ( $C_L/C_D @trim$ )	OBJ 2 ( $C_{L_{max\_usable}}$ )
Pareto 1	11.367	11.291
Pareto 2	11.573	10.874
Pareto 3	11.671	10.545
Pareto 4	11.745	10.480
Pareto 5	11.793	9.654
Pareto 6	11.844	9.649
Pareto 7	12.335	9.556
Pareto 8	12.358	9.442
Pareto 9	12.634	9.247

The number of designs that are violating the constraints are given in Table 4.3. Some of the designs violate more than one constraints. As a result, 560 designs out of 1000 violate the constraints for total of 1142 times. Also the percentages of constraints, which ranks the constraints according to the number of violations, are given in Figure 4.6.

Table 4.3. *Number of Designs Violates the Settled Constraints (Trial I)*

Constraints	<i>Number of Designs Violates the Constraint</i>
Geometric Constraints_v1	459
Geometric Constraints_v2	511
Control Effectiveness_v1	65
Control Effectiveness_v2	87
Static Stability_v1	219
Static Stability_v2	232

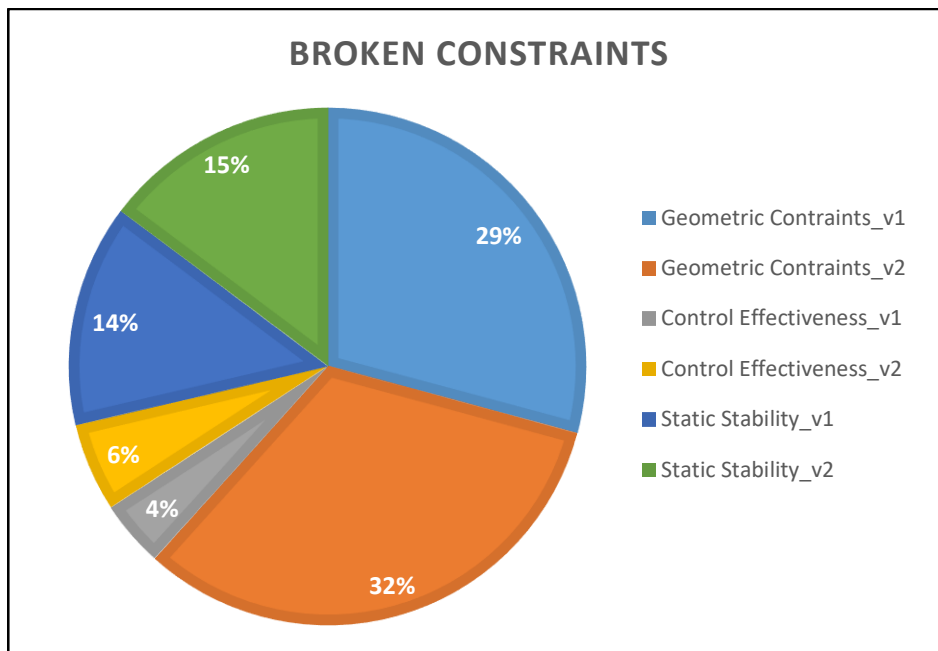

Figure 4.6. Percentage of Broken Constraints (Trial I)

As it can be seen in Figure 4.1, there are some unfeasible designs which may have better values than the Pareto set solutions for both objectives. Some of them are isolated and shown in Figure 4.7. It is important to understand the reason why these designs are unfeasible. The designer might have the chance to ease the constraints

with respect to their advantages. For these unfeasible designs, both the objective values and the broken constraints are summarized in Table 4.4. The 1<sup>st</sup> unfeasible solution is statically unstable for both versions of the missile. Also, this unfeasible solution breaks the constraint for control effectiveness. The 2<sup>nd</sup> unfeasible solution is statically unstable only for v2. The 3<sup>rd</sup> solution is unfeasible because of the geometric constraints such that the wing cannot be folded for the v2 geometry. As it is not possible to carry a missile unfolded in any launch platform, the solution is unfeasible.

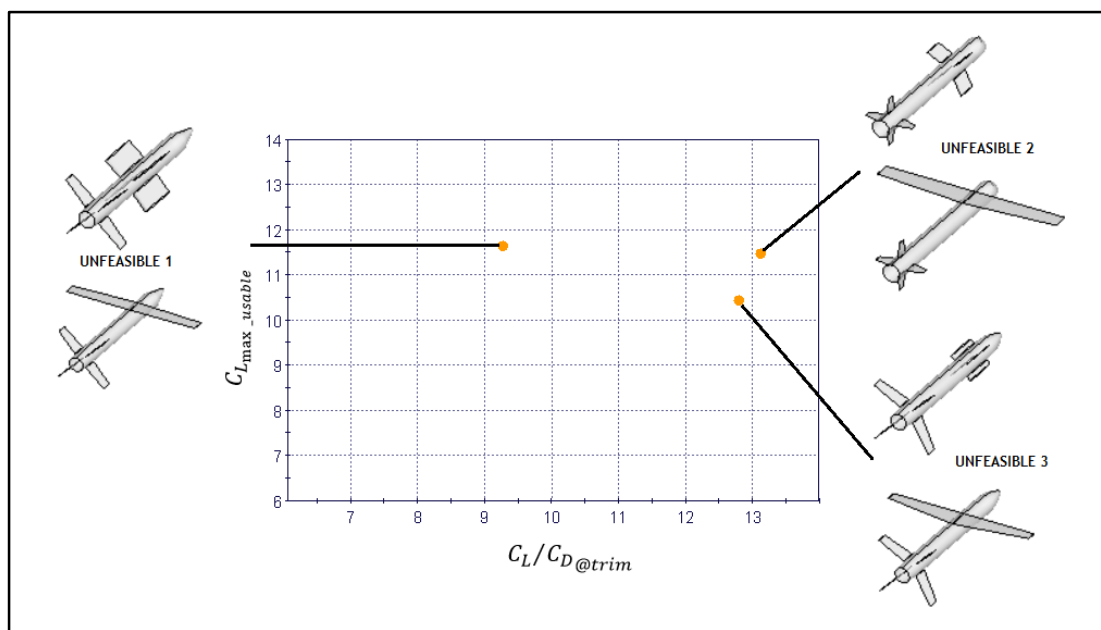

Figure 4.7. Scatter Chart of Unfeasible Designs (Trial I)

Table 4.4. Numerical Values of Objective Functions and Broken Constraints of Some Unfeasible Constraints (Trial I)

Parameters	$(C_L/C_D @trim)$	$(C_{L_{max\_usable}})$	Broken Constraints
Unfeasible 1	9.277	11.647	Static stability (v1 & v2) Control Effectiveness (v2)
Unfeasible 2	13.115	11.461	Static Stability (v2)
Unfeasible 3	12.790	10.435	Geometric constraints (Wing length is very long to fold, v2)

Another important issue for a designer is to understand the effects of the parameters on the system. For the selected objectives, the effects of the parameters are analyzed. The effects of some of the geometric parameters for OBJ 1 is given in Figure 4.8. The height of the bars is called the effect size and shows the strength of the relationship between the output and the input values. An effect size greater than zero indicates a direct relationship with the input variable, whereas a value less than zero indicates an inverse relationship. This parameter is expressed as the difference between Mean- and Mean+ where, Mean- and Mean+ are the mean of the values for the output variable in the upper part of the domain of the input variable. For this reason, this parameter creates an ordered list of the parameters based on the level of importance. Low values indicate that there is no relationship between the input and output variables, so, probably, it is possible to ignore that variable. For this case study, the tail wing span has the largest positive effect followed by the nose length and the root chord of the wing as they increase the value of the maximum usable lift coefficient, ( $C_{L_{max\_usable}}$ ). On the contrary, the wing sweep angle and the distance from the missile's nose to the wing leading edge have the most adverse effect on the OBJ 1. In the main effects chart in Figure 4.8, only the most effective parameters are shown and the parameters not shown in the chart have negligible effects compared to the ones shown.

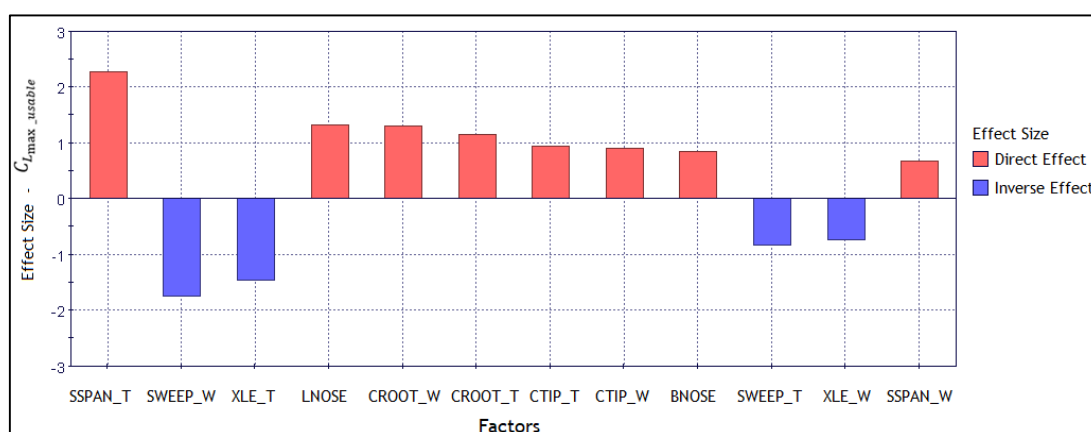

Figure 4.8. Main Effects Chart for OBJ 1 (Trial I)

Also the main effect chart for OBJ 2 is given in Figure 4.9. The most effective parameters show similarity for both objectives as these two objectives are not conflicting with each other. Similar to OBJ 1, the tail span, the nose length and the root chord have the most positive effect for OBJ 2. However, the sequence of the most effective parameters and the effect size change. Although the tail tip chord, the wing tip chord, the nose bluntness, and the wing leading edge's distance from the missiles nose have higher impacts on OBJ 1, they are less effective for OBJ 2. Instead of the parameters mentioned above, the strake span, the thickness of tail's airfoil, the length of after body and the length of center body have higher impact on OBJ 2 compared to OBJ 1.

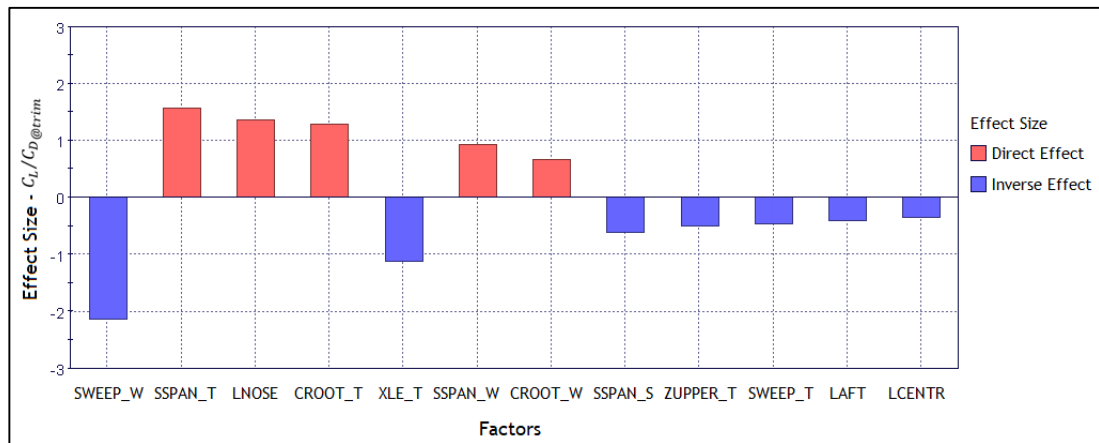

Figure 4.9. Main Effects Chart for OBJ 2 (Trial I)

#### 4.2. Modular Design Single Objective Optimization with MOGA

For the single objective optimization trials, Trials II and III, both the DoE and the optimization algorithm parameters are the same as the previous case of Trial I as summarized in Table 4.1. Also, the constraints are exactly the same as the previous optimization trial.

The history graphics of the feasible modular designs for the single objective as  $C_L/C_D @trim$  and  $C_{L_{max\_usable}}$  with respect to the design ID, is given in Figure 4.10 and Figure 4.11, respectively. As expected, the increase in the values of the objective in the single objective optimization is steeper compared to the increase in multi-objective optimization's (Trial 1) objective values.

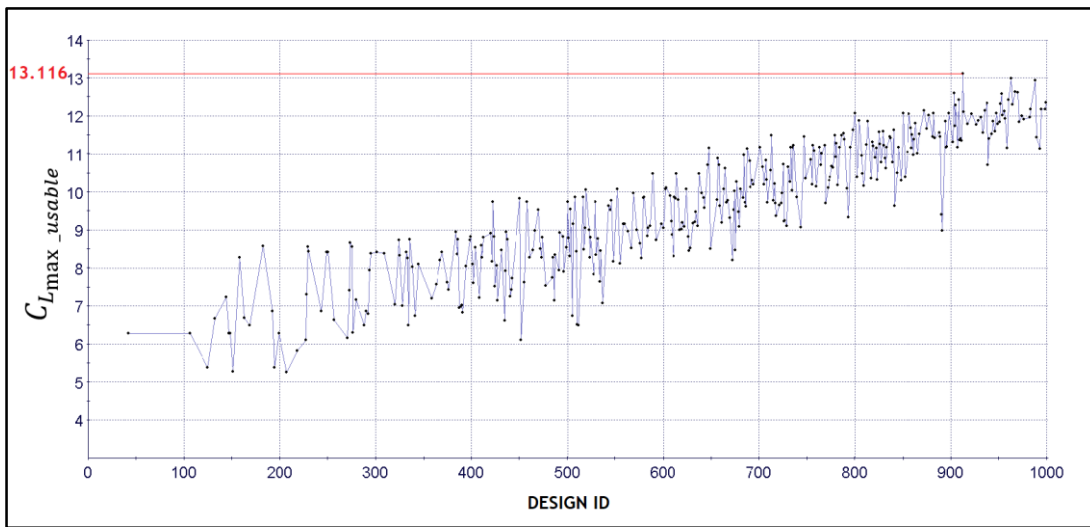

Figure 4.10. History Graphics of Maximum Usable Lift Coefficient (Trial II)

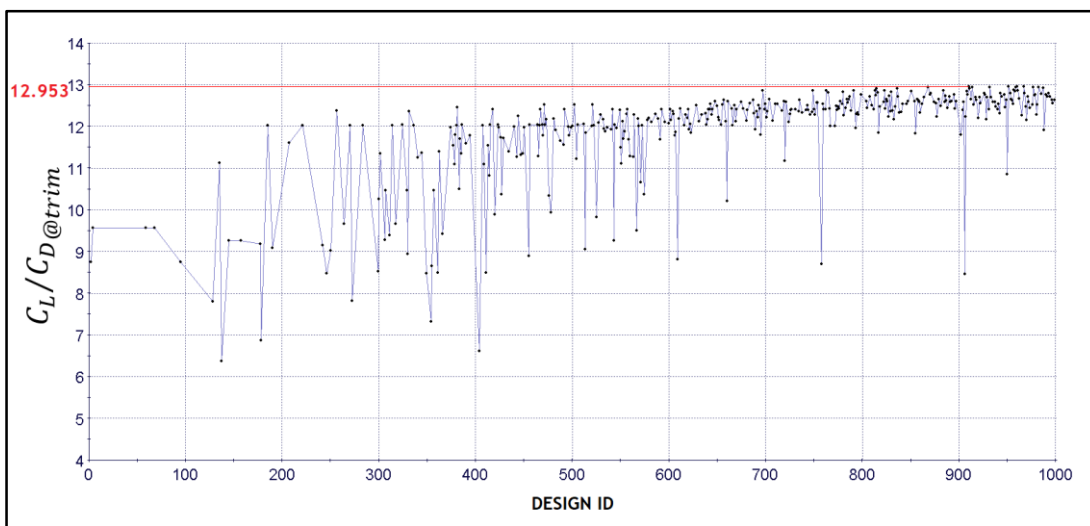

Figure 4.11. History Graphics of Lift-to-Drag Ratio at Trim Condition (Trial III)



The best solutions for single objective optimizations and the highest values of pareto set designs are given in Table 4.5. Unsurprisingly, for single-objective optimizations, the values for objective functions are higher.

Table 4.5. *Comparison of Multi-Objective and Single Objective Optimizations (Trial II and III)*

Design	$C_L/C_D @trim$	$C_{L_{max\_usable}}$
Design with highest value of Pareto Set	12.634	11.291
Value of the best design for single-objective optimization	12.953	13.116

### 4.3. Fixed Design Multi-Objective Optimization with MOGA

In this fixed design optimization trial, as there is no need to satisfy the constraints of the 1<sup>st</sup> version missile (v1), the design confronts with fewer constraints which are only for the 2<sup>nd</sup> version (v2). Although the number of constraints decreases, due to its nature, the optimization algorithm enforces the design to its limits. As a result, there is no direct proportion between the number of constraints and the number of designs that violate them. In this optimization trial with multi-objectives (Trial IV), 579 designs out of 1000 violate at least one constraint. The percentage of the broken constraints are also shown in Figure 4.12.

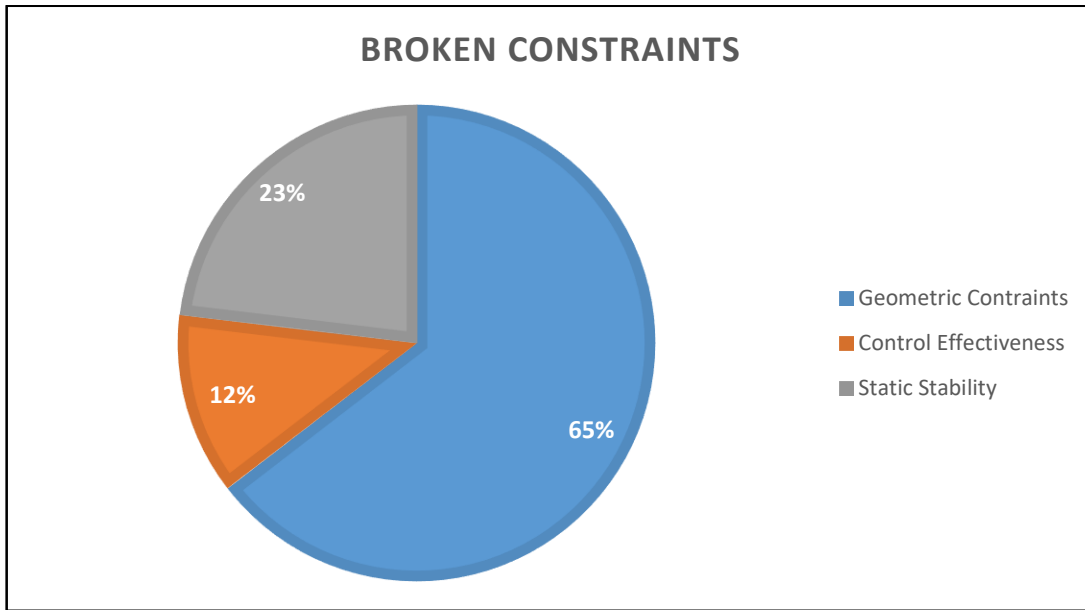

Figure 4.12. Percentage of Broken Constraints (Trial IV)

Since the optimization is again a multi-objective optimization, a pareto optimum set is obtained instead of the best solution. The values of the objective functions for the 2<sup>nd</sup> version solutions (v2) of Trial IV are given in Table 4.6. Together with the objective function values, the estimated range values are also given. For the selected three pareto solutions, the maximum lift-to drag ratio is reached at the Mach number of 0.6.

Table 4.6. Numerical Values of Objectives for Single Version Optimization (Trial IV)

Optimal Solutions	$C_L/C_D$ @trim	Estimated Range	$C_{L_{max\_usable}}$
Pareto 1	19.634 (M=0.6, AoA=2°)	149.6 km	21.520
Pareto 2	19.069 (M=0.6, AoA=2°)	145.3 km	26.513
Pareto 3	17.682 (M=0.6, AoA=3°)	134.7 km	26.911

The comparison of the optimum solutions for the single version with wings (v2) only of Trial IV and the optimum solutions of 2<sup>nd</sup> version (v2) obtained from Trial I for the coupled optimization where the modular designs of v1 and v2 optimized together, is shown in Figure 4.13.

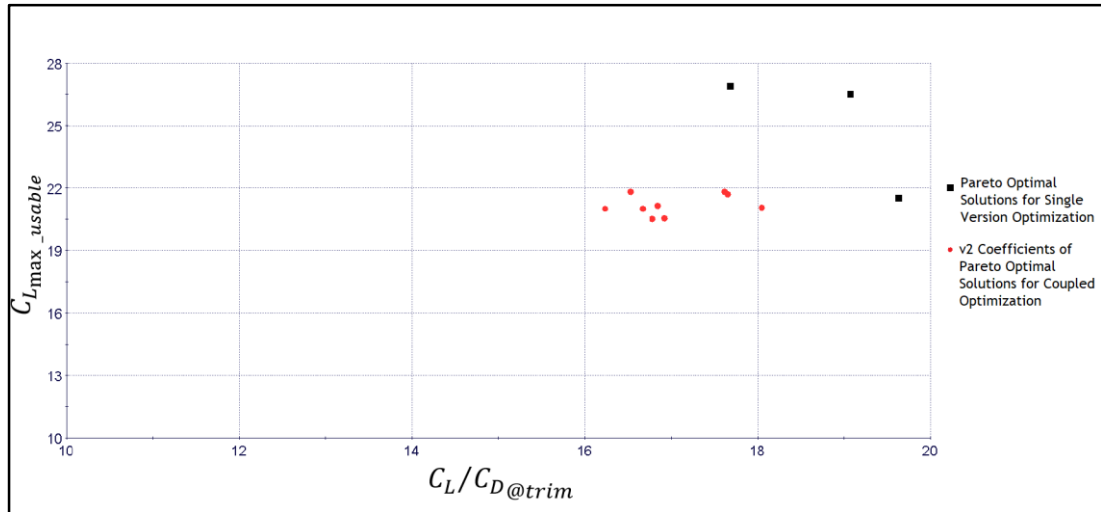

Figure 4.13. Pareto Optimum Solutions for Single Version Optimization and 2<sup>nd</sup> Version Values of Coupled Optimization Pareto Optimal Set (Trial IV: black and Trial I: red)

As explained in section 4.1, for Trial 1, the optimization is executed and the pareto set is obtained by considering the objective functions (OBJ1 and OBJ2) with the pre-determined weighting factors for both versions of the missile (v1 and v2). Every solution in the pareto set consists of one version with strakes and one version with wings. In Table 4.7, the numerical values of the lift to drag ratio at trim condition ( $C_L/C_{D@trim}$ ) and the maximum usable lift coefficient ( $C_{Lmax\_usable}$ ) for the pareto optimum solutions only for the 2<sup>nd</sup> version missiles are given, so, the values are different from the objective function values given in Table 4.2. As observed from Figure 4.13, and Tables 4.6 and 4.7, the values of the results of the single version optimization are higher for both objectives as compared to the results of the coupled version optimization for the 2<sup>nd</sup> version.

Table 4.7. Aerodynamic Parameters of 2<sup>nd</sup> Version Missiles in Coupled Optimization (Trial I)

Optimal Solutions	$C_L/C_D$ @trim (V2)	Estimated Range	$C_{L_{max\_usable}}$ (V2)
Pareto 1	16.238	123.7 km	21.022
Pareto 2	16.533	126.0 km	21.809
Pareto 3	16.673	127.0 km	20.994
Pareto 4	16.779	127.9 km	20.520
Pareto 5	16.847	128.4 km	21.151
Pareto 6	16.920	128.9 km	20.537
Pareto 7	17.622	134.3 km	21.812
Pareto 8	17.654	134.5 km	21.691
Pareto 9	18.049	137.5 km	21.075

#### 4.4. Modular Design Multi-Objective Optimization with SIMPLEX Algorithm

This multi-objective optimization trial (Trial V) is performed to reveal the differences between two optimization algorithms: Genetic Algorithm and Simplex Algorithm. For this reason, both the DoE and the optimization parameters remain the same as in Table 4.1. If N is the number of the design parameters used in the optimization, which is equal to 27 in the case study used in this thesis, the Simplex Algorithm needs N+1 initial designs to start the optimization. Therefore, in this optimization trial, the Simplex Algorithm uses only the first 28 designs generated by SOBOL algorithm to start the optimization routine of the algorithm.

As stated before in this optimization trial, the weighted sum approach is used to identify the objective function. As a result of having one objective function to optimize, in this trial the best solution can be identified instead of a pareto optimal set.

In the first optimization trial using Simplex Algorithm, a total number of 1000 designs is allowed as in previous optimization trials. However, in this initial optimization, the algorithm can only find 8 feasible designs out of 1000. 992 designs out of 1000 violate the constraints for total 2738 times. The percentage of the constraints, which is useful for ranking the constraints to the number of violations, are given in Figure 4.14. Although the percentage of broken constraints show similarity with previous optimizations, the total number of unfeasible designs are much more.

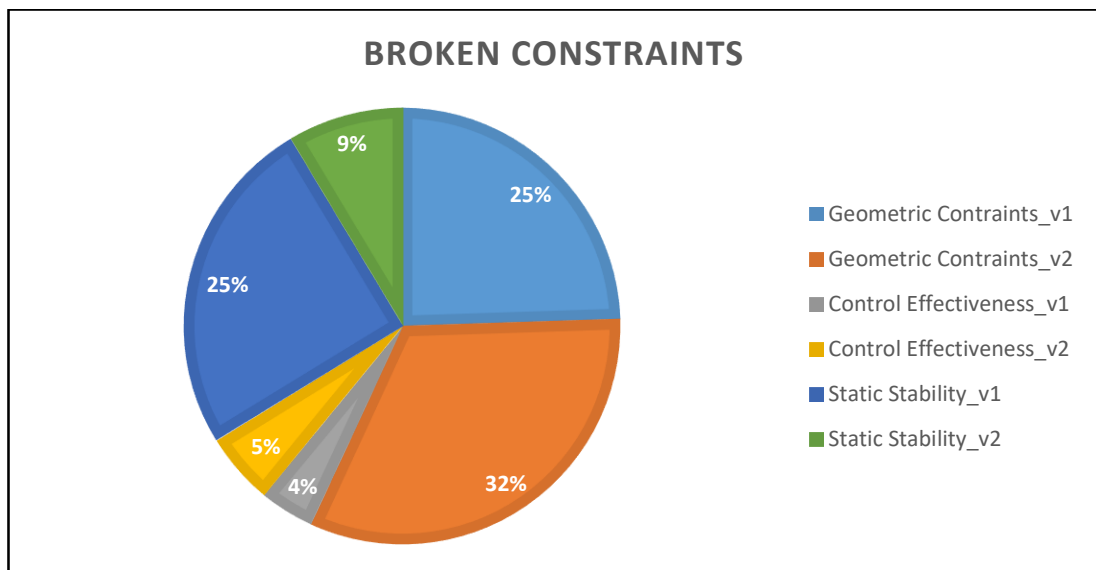

Figure 4.14. Percentage of Broken Constraints (Trial V)

After this initial optimization and getting a limited number of feasible designs, the same procedure is repeated by a total number of 5000 designs. In this second trial, the algorithm is managed to obtain 134 feasible designs. The best design, according to combined objective function, and the pareto optimum set obtained in Section 4.1 by the Genetic Algorithm are summarized in Table 4.8.

Table 4.8. Numerical Values of Objective Functions of Pareto Optimal Solutions (Genetic Algorithm) and Best Solution of Simplex Algorithm

Optimal Solutions	OBJ 1 ( $C_L/C_D @trim$ )	OBJ 2( $C_{Lmax\_usable}$ )
Simplex Best Solution	9.800	10.4359
Pareto 1 (GA)	11.367	11.291
Pareto 2 (GA)	11.573	10.874
Pareto 3 (GA)	11.671	10.545
Pareto 4 (GA)	11.745	10.480
Pareto 5 (GA)	11.793	9.654
Pareto 6 (GA)	11.844	9.649
Pareto 7 (GA)	12.335	9.556
Pareto 8 (GA)	12.358	9.442
Pareto 9 (GA)	12.634	9.247

Although the Genetic Algorithm evaluated a smaller number of designs, it is concluded from the optimization results that the solutions obtained by the Genetic Algorithm are better compared to the solution obtained with the Simplex Algorithm. The advantage of the Simplex Algorithm is the ability to reach to the optimum solution faster. However, as it needs to evaluate a greater number of designs, the mentioned advantage is disappeared.

#### 4.5. Comparison of Results with Validated Missile

In order to validate the developed design tool, the test case results are compared with the existing GBU-39 missile, which is a well-known 250 lb class of munition as shown in Figure 4.15. Information about the GBU-39 missile is collected from open sources in the literature [Boeing, 2019]. The comparisons of pareto optimal solutions obtained

at section 4.3 and GBU-39 are given in Table 4.9. Although the total lengths are similar, the GBU-39 spare more length for nose and aft body and decreases the length of center body. For the rest of the geometric parameters, the pareto solutions and the GBU-39 are similar, and the differences in the values are less than 10%.



Figure 4.15. GBU-39 Missile [Boeing, 2019]

With the geometric parameters given in Table 4.9, the value of lift-to-drag ratio at the trim condition for the GBU-39 is calculated by using the developed design tool as 13.232. The typical launch altitude for a gliding missile is 30 000 ft. Using the gliding missile's range formula:

$$R = C_L/C_{D@trim} * h_{release}$$

The range of the GBU-39 can be calculated as 121 km. The real range of existing GBU-39 is 110 km. Although some of the parameters of the GBU-39 cannot be found in literature and some assumptions are made for such parameters if needed, the tool is able to estimate the range with an only 9% error.

Table 4.9. GBU-39 Comparison Results

Parameter	Pareto 1	Pareto 2	Pareto 3	GBU-39
TNOSE	OGIVE	OGIVE	OGIVE	-
LNOSE	0.25 m	0.25 m	0.25 m	0.391 m
BNOSE	0.02 m	0.015 m	0.01 m	-
DNOSE	0.18 m	0.18 m	0.18 m	0.18 m
LCENTR	1.38 m	1.4 m	1.4 m	1.114 m
DCENTR	0.18 m	0.18 m	0.18 m	0.19 m
TAFT	CONIC	CONIC	CONIC	-
DAFT	0.166 m	0.168 m	0.17 m	0.165 m
LAFT	0.15 m	0.15 m	0.15 m	0.260 m
SSPAN_W	0.75 m	0.75 m	0.7 m	0.9 m
CROOT_W	0.15 m	0.22 m	0.25 m	0.104 m
CTIP_W	0.13 m	0.14 m	0.15 m	0.099 m
XLE_W	0.65 m	0.65 m	0.65 m	0.5 m
SWEEP_W	2.5°	5°	7.5°	30°
SSPAN_T	0.3 m	0.3 m	0.3 m	0.271 m
CROOT_T	0.11 m	0.11 m	0.11 m	0.095 m
CTIP_T	0.09 m	0.09 m	0.11 m	0.09 m
XLE_T	1.575 m	1.575 m	1.525 m	1.736 m
SWEEP_T	10°	7.5°	20°	15°



## CHAPTER 5

### CONCLUSION AND FUTURE WORK

In this thesis, a design tool is developed that can optimize a generic air-to-surface, tail controlled, guided missile's outer geometry while taking into consideration the modularity of lifting surfaces by investigating two different versions of the same configuration. In order to widen the scope of the operational concepts, it is important to take into account the modularity of lifting surfaces. By using interchangeable strakes and wings, the missile can fulfill several different missions in the most cost-effective manner.

At the very beginning of the optimization cycle, the objectives are selected as to maximize both the lift-to-drag ratio at the trim condition and the maximum usable lift coefficient. These two aerodynamic parameters are important for gliding missiles to increase the range and the maneuverability. Along with the design objectives, also the design constraints are determined. The aerodynamic and structural constraints are defined in the design tool.

Missile DATCOM software is used for aerodynamic predictions, as it is a self-proved and widely used semi-empiric aerodynamic prediction code. The flight conditions, the missile's geometry and optionally the propulsion data are the inputs required by Missile DATCOM. Since a generic guided munition does not have a propulsion system, the propulsion data is excluded. As usual flight speed of guided munitions is between 0,1 Mach and 1,2 Mach with an angle of attack range of  $0^\circ$  to  $10^\circ$ , the flight regime is limited to these ranges for Mach Number and angle of attack. Furthermore, in order to define the outer geometry of the missile, several geometric parameters are set beforehand.

In order to initiate the design cycle, the starting set, DoE, is constituted by Sobol Algorithm. As optimization algorithm, to enhance the solutions both the Genetic Algorithm and the Simplex Algorithm are employed.

In this thesis, the several different design combinations are studied in order to evaluate the effects of different design features. The effect of the modularity of the lifting surfaces on design, the difference between single and multi-objective optimization and the impact of the optimization algorithm are analyzed. When only one objective is maximized, even though it gives better solutions than multi-objective optimization in terms of that particular objective, there is no significant improvement as the objectives are not conflicting with each other. When comparing the fixed missile design with the modular missile design, since the modularity increases the number of constraints, the objective function values are observed to be decreased. However, for the selected test case, 250 lb guided munition, this decrease is not very high. Even so, this modularity effect shall be investigated for each case study. While optimizing a gliding missile's outer geometry, it is also concluded that the Genetic Algorithm is having better performances as expected compared to the Simplex Algorithm as it provides better solutions even with evaluating fewer designs. As a result, a preliminary multi-disciplinary and multi-objective conceptual design tool which is using the DoE and GA is developed and tested for the design of guided missiles with modular aerodynamic geometric modifications with strakes or with wings.

In future studies, the present tool's capabilities could be improved according to the several suggestions mentioned below:

- For aerodynamic predictions, the first-principles physics based Computational Fluid Dynamics (CFD) codes can be used instead of Missile DATCOM software which uses basic aerodynamic theories together with empirical correlations. By considering the time consumed for the aerodynamic predictions and the huge number of trials during the iterative conceptual design phase, it is recommended to narrow down the designs with Missile DATCOM

at first, and then to use CFD codes at the end of the optimization cycle for detailed analysis.

- Although implementing airfoil geometry optimization into such a tool is not practicable, the selection of airfoil shape from various alternatives can be considered in future studies. The airfoil selection will affect the aerodynamic performance and therefore the optimization results for final geometry.
- The number of related design objectives can be increased. Maximizing negative AoA for vertical impact, maximizing volume for maximum warhead effectiveness and minimizing RCS for survivability may be other design objectives.
- A dynamic model of 3 DOF or 6 DOF simulations for the missile can be implemented to the design tool for more accurate range calculations.



## REFERENCES

- Alberico, J., 1992. The Development of an Interactive Computer Tool for Synthesis and Optimization of Hypersonic Airbreathing Vehicles, American Institute of Aeronautics and Astronautics, AIAA-92-5076.
- Arslan E. M. 1996. Optimum Trajectories for Air-to-Surface Missiles Using Direct Collocation and Nonlinear Programming, M.S. Thesis, Aerospace Engineering Department, METU, Ankara.
- Arslan K. 2014. Aerodynamic Optimization of Missile External Configurations, M.S. Thesis, Aerospace Engineering Department, METU, Ankara.
- Atik, H., Birsen E., Ilgaz M., Karbancıoğlu İ. M., Katırcı A., Mahmutyazıcıoğlu E., Yalçın L. and Başoğlu O. 2008. Prediction Capabilities and Comparison of Panel, Semi-Empiric and CFD Codes for Missile Aerodynamic Analysis, AIAA-2008-6224.
- Aytar-Ortaç, S. 2002. Optimal External Configuration Design of Missiles, M.S. Thesis, Mechanical Engineering Department, METU, Ankara.
- Bennett, B. K. 1997. Conceptual Design Synthesis Tool for Arbitrary-body Missiles, 15th Applied Aerodynamics Conference, Atlanta, GA, USA, AIAA 1997-2281.
- Bingol, M. 2000. Multidisciplinary Design Optimization of Missiles M.S. Thesis, Aerospace Engineering Department, METU, Ankara.
- Blake, W. B. Rosema C., Doyle J, Auman L. and Underwood M. 2011. Missile Datcom: User's Manual – 2011 Revision, Air Force Research Laboratories Document AFRL-RB-WP-TR-2011-3071.
- Cantu-Paz, E. 2001. Efficient and Accurate Parallel Genetic Algorithms, Massachusetts, USA, Springer.
- Chin, S. S. 1961. Missile Configuration Design. McGraw-Hill Book Co., Inc., New York.
- Crowell G. A. 1996. The Descriptive Geometry of Nose Cones”, <http://www.scribd.com/doc/60921375/The-Descriptive-Geometry-of-NoseCone>. (Last accessed date: May 25 2019)
- Dede E. 2011. External Geometry and Flight Performance Optimization of Turbojet Propelled Air to Ground Missiles, M.S. Thesis, Aerospace Engineering Department, METU, Ankara.

Edgeworth, F.Y. 1891. *Mathematical Psychics; an Essay on the Application of Mathematics to Moral Sciences*, London, England, C.K. Paul and Co. (Kelley A. M., 1961, Reprints of Economic Classics, New York)

Etkin, B. and Reid, L. D. 1996. *Dynamics of Flight Stability and Control*, 3<sup>rd</sup> Edition.

Fisher R. A. 1971. *The Design of Experiments*, 9<sup>th</sup> Edition, New York, America, Hafner Publishing Company.

Fleeman E. L. 2001. *Tactical Missile Design*. Reston, Virginia: American Institute of Aeronautics and Astronautics Inc.

Fonseca C. M. and Fleming P. J. 1993. *Genetic Algorithms for Multiobjective Optimization: Formulation, Discussion and Generalization*, Genetic Algorithms: Proceeding of the Fifth International Conference, San Mateo California.

Gen, M., Cheng, R., 1997. *Genetic Algorithms and Engineering Design*, USA, Wiley Interscience.

Goldberg, D. E. 1989. *Genetic Algorithms in Search, Optimization, and Machine Learning*, Reading: Addison-Wesley.

Günaydin, K. 2014. *Response Surface Based Performance Analysis of an Air Defense System*, M.S. Thesis, Aerospace Engineering Department, METU, Ankara.

Karakoç A. 2011. *Multi-Disciplinary Design and Optimization of Air to Surface Missiles with Respect to Flight Performance and Radar Cross Section*, M.S. Thesis, Mechanical Engineering Department, METU, Ankara.

Karslı G. 2004. *Simulated Annealing for the Generation of Pareto Fronts with Aerospace Applications*, MS Thesis, Aerospace Engineering Department, METU Ankara.

Kıvanç A. 2014. *Aerodynamic Optimization of Missile External Configurations*. M.S. Thesis, Aerospace Engineering Thesis, METU, Ankara.

Kopp C. 2007. *Boeing GBU-39/B Small Diameter Bomb I, Raytheon GBU-53/B Small Diameter Bomb II Technical Report*.

<http://www.ausairpower.net/APA-SDB.html> (Last accessed: July 30 2019)

Konak, A., Coit, D. W., and Smith, A. E. 2006. Multi-objective optimization using genetic algorithms: A tutorial. *Reliability Engineering and System Safety*, 91(9), 992-1007. <https://doi.org/10.1016/j.ress.2005.11.018>.

Lin M.H., Tsai J. F., and Yu C. S. 2012. A Review of Deterministic Optimization Methods in Engineering and Management, Taiwan, Hindawi Publishing Corporation Mathematical Problems in Engineering, Article ID: 756023.

Maurice A. F., 2009. Aerodynamic Performance Predictions of a SA-2 Missile Using Missile DATCOM, Master's Thesis, Naval Postgraduate School. Monterey, California.

MIL-HDBK-762, 1990. Design of Aerodynamically Stabilized Free Rockets, Department of Defense, 17 July 1990.

MIL-STD-1289D Change1, 2004. Airborne Stores, Ground Fit and Compatibility Requirements, Department of Defense Standard Practice. (Superseding MIL-STD-1289D, 24 September 2003)

Missile Types, <https://www.britannica.com/technology/missile>, (Last accessed date: May 14 2019).

ModeFrontier, <https://www.esteco.com/modelfrontier>, (Last accessed date: July 30 2019).

Nelder J. A. and Mead R., 1965. A Simplex Method for Function Minimization, Computer Journal, 7, 308-313 p.

Nielsen J. N. 1967. Missile Aerodynamics. Library of Flight Series, AIAA Education Series, USA.

Oehlert G. W. 2010. A First Course Design and Analysis of Experiments, University of Minnesota.

Osterhuber R. 2011. FCS Requirements for Combat Aircraft – Lessons Learned for Future Designs, STO-AVT-189, Workshop on Stability and Control, Portsmouth

Öztürk M. Y. 2002. Multi-Objective Design Optimization of Rockets and Missiles, M.S. Thesis, Aerospace Engineering Department, METU, Ankara.

Pareto, V., In: Schiöler, A.S., Page, A.N. 1927. Manual of Political Economy. (translated from 1927 French edition by Ann S. Schiöler, Augustus M. Kelley Publishers, New York, 1971.)

Poles S. 2003. The Simplex Method, Esteco Technical Report 2003-2005.

Savine A. 2019. Modern Computational Finance AAD and Parallel Simulations, Canada, John Wiley & Sons Company.

Sobol I. M. 1967. On the Distribution of Points in a Cube and the Approximate Evaluation of Integrals, USSR Computational Mathematics and Mathematical Physics, Vol. 7, No. 4 pp. 86-112.

Tanıl Ç. 2009. Optimal External Configuration of a Missile, M.S. Thesis, Mechanical Engineering Department, METU, Ankara.

Teo H. H., 2008. Aerodynamic Predictions, Comparisons, and Validations Using Missilelab and Missile DATCOM, Master's Thesis, Naval Postgraduate School, Monterey, California.

Turco A. 2011. New Constraints Handling in Simplex, Esteco Technical Report 2011-002.

Tyan M., Nguyen N. V., Lee J.W., 2015. Improved Missile Control Effectiveness Prediction Method Using High Fidelity Analysis Tool: Jeju Island, Korea: Proceeding of 2015 Asian-Pacific Conference on Aerospace Technology and Science.

Utalay, S. 1999, Missile Design Optimization Using Simulated Annealing Technique, M.S. Thesis, Department of Aerospace Engineering, METU, Ankara.

Zitzler E., 1999. Evolutionary Algorithms for Multiobjective Optimization: Methods and Applications, Eidgenössische Technische Hochschule Zürich Swiss Federal Institute of Technology Zurich.



## **APPENDICES**

### **A. OPTIMIZATION WORKFLOW**

The optimization procedure is shown in Figure A.1.

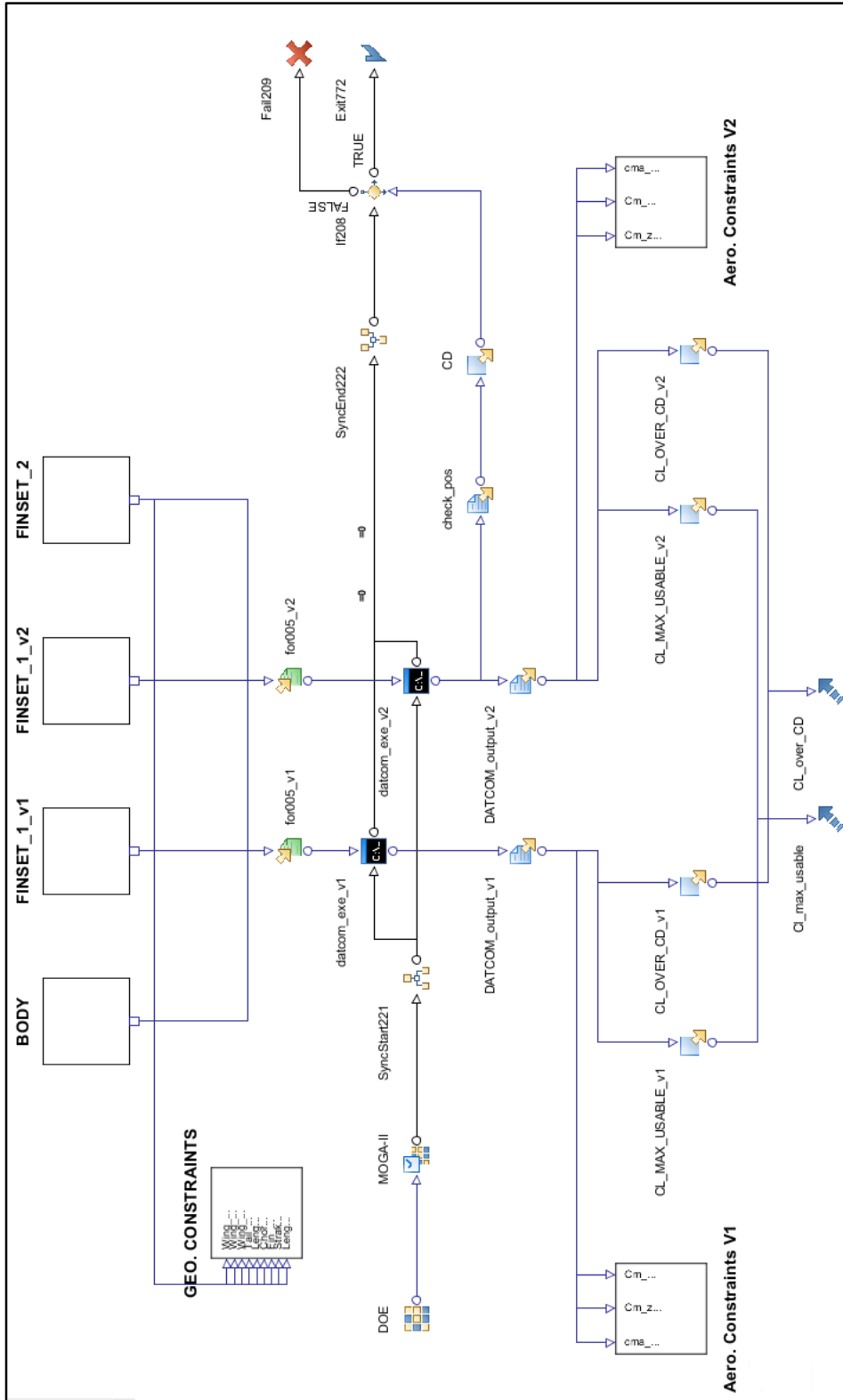

Figure A.1. Optimization Procedure

## B. PROPERTIES of RECENT REVISIONS of MISSILE DATCOM

Table B.1 shows the properties of recent revisions of the Missile DATCOM software used in this study [Blake, W. B, *et al.*, 2011].

Table B.1. *Properties of versions of Missile DATCOM*

Revision	Release	Documentation	
01/06	9	AIAA-2003-3668 AIAA-2005-4833 AIAA-2005-4971	Code clean-up and restructuring Cambered body capability Revised body drag (bluntness, high AOA)
07/07	10	AIAA-2007-3936 AIAA-2007-3937	Rolling moment for elliptical bodies Improvements to trailing edge flap control increments Improvements for low aspect ratio fins
08/08	11	AIAA-2009-0907 AFRL-TR-2009-3015	Nine fin sets with up to 8 fins each Revised body drag Moment contribution from protuberances
03/11	12	AIAA 2009-3853 AIAA 2011-1240 AIAA 2011-1241	Improved fin-shed vortex modeling Up to 20 vortices shed per fin Output file option for vortex visualization

### C. MISSILE DATCOM INPUT/OUTPUT FILES

Table C.1 shows the input and output file names and their content of the Missile DATCOM software used in this study [Blake, W. B, *et al.*, 2011].

Table C.1. *Missile DATCOM Input and Output Files*

Unit	Name	Usage
2	for002.dat	Namelists for the input "case" are read from unit 8 and written to unit 2.
3	for003.dat	Plot file of aerodynamic data, written at user request (using PLOT card) to unit 3
5	for005.dat	User input file read from unit 5
6	for006.dat	Program output file written to unit 6
8	for008.dat	User input cards read from unit 5 are written to unit 8 after they have been checked for errors.
9	for009.dat	Body geometry data, written at user request to unit 9
10	for010.dat	Body pressure coefficient data at angle of attack, written at user request to unit 10 when using PRESSURES card.
11	for011.dat	Fin pressure coefficient data, written at user request to unit 11 when using PRESSURES card
12	for012.dat	Body pressure coefficient and local Mach number at zero angle of attack, written at user request to unit 12 when using PRESSURES card
20	for020.dat	Total configuration force and moment coefficient data, damping derivatives and flight conditions, written at user request (using PLOT card). File is formatted for use with software developed with Adaptive Modeling Language (AML).
21	for021.dat	Total configuration force and moment coefficient data, damping derivatives, flight conditions and control deflections, written at user request (using PLOT card). File is formatted for use with the Aviator Visual Design Simulator (AVDS).
22	for022.dat	Configuration geometry file compatible with the commercial software package Tecplot. Only geometry for the body and fins are printed. No geometry is provided for inlets or protuberances.
42	for042.csv	All standard data written in rows and columns with headers
43	for043.csv	Fin data written in rows and columns with headers